

Ronix[®]
Premium Quality

**INFRARED THERMOMETER
RH-9601**

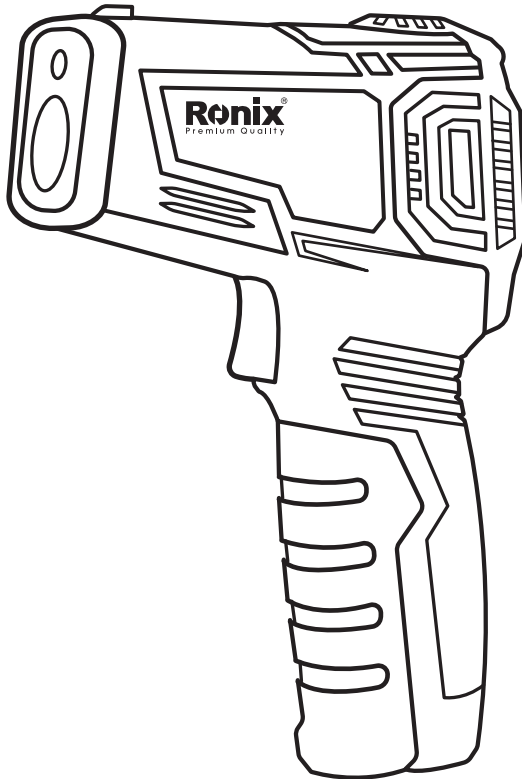

SPECIFICATIONS

Model	RH-9601
IRT temperature	-50°C-550°C (-58°F-1022°F) -50°C-0°C (-58°F - 32°F): ±3°C 0°C -550°C (-32°F-1022°F): ±2% or ±2°C
display	Color display
Laser	Laser
D:S	12:1
Emissivity	0.10-1.00
Spectral response	8-14um
Response time	<0.5S
°C/°F display	Yes
Temperature upper / lower limit alarm (Red)	Yes
Data hold	Yes
Max	Yes
Low battery indication	Yes
Auto Power Off	Yes
Back light	Yes
Power	1.5V AAA battery
Weight	112g
size	145mm × 92mm × 45mm
Safety Rating	EN61326, EN60825
Supplied in	Ronix color box
Includes	2 pcs 1.5V AAA battery
Max. Exhibition	3999

PARTS LIST

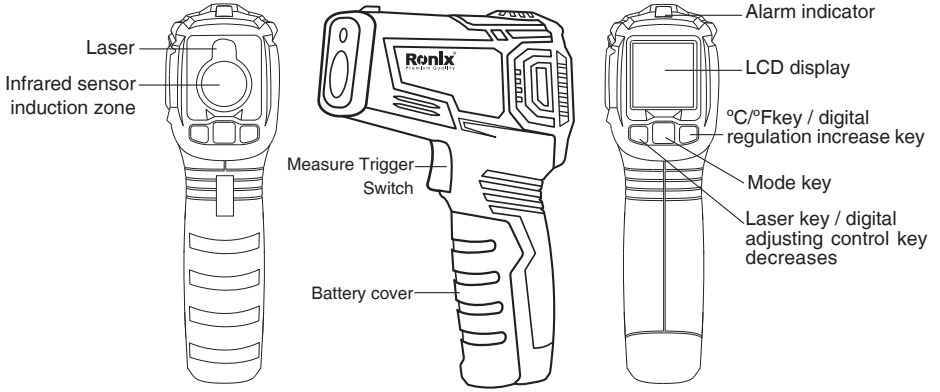

LCD DESCRIPTION

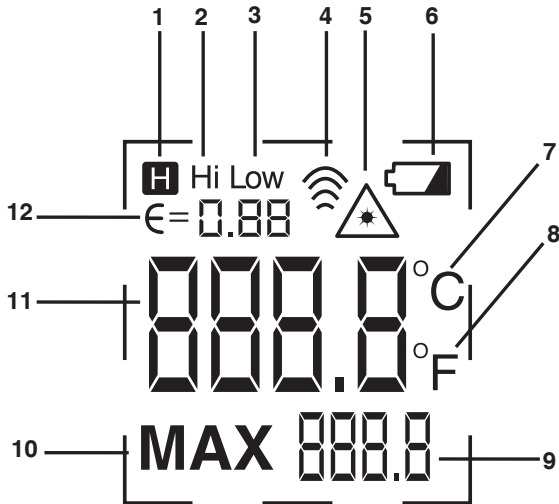

- 1-Data hold indicator
- 2-Temperature upper limit alarm indicator
- 3-Temperature lower limit alarm indicator
- 4-Measuring indicator

- 5-Laser on indicator
- 6-Low battery indicator
- 7-Centigrade unit
- 8-Fahrenheit degree unit
- 9-Maximum display
- 10-Maximum indicator
- 11-Temperature display
- 12-Emittance display

SAFETY STATEMENT

“Caution” mark refers to the condition and operation which may cause damage to the instrument or equipment.

It requires that you must be careful during the execution of the operation. If incorrectly perform the operation or do not follow the procedure, it may damage the instrument or equipment. In the circumstances that such conditions are not met or not fully understood, please do not continue to perform any operation indicated by the caution mark.

“Warning” mark indicates the condition and operation which may cause danger to users.

It requires that you must pay attention during the execution of this operation. If incorrectly perform the operation or do not follow the procedure, it may result in personal injury or casualties. In the circumstances that such conditions are not met or not fully understood, please do not continue to perform any operation indicated by the warning mark.

The infrared thermometer is suitable for non-contact temperature measurement. The thermometer determines the surface temperature of the object by measuring the infrared energy of the radiation from the surface of the object.

SAFETY OPERATION SPECIFICATIONS

WARNING!

To prevent eye injury or personal injury:

- Please read the manual carefully before using the product.
- Please do not look at the laser directly. Do not direct laser direct to humans or animals or indirectly from the reflecting surface.
- If the instrument works abnormally, do not use.
- Do not use optical tools (such as binocular, telescope, microscope, etc.) to look directly at the laser. Optical tools may focus on lasers, thereby damaging the eyes.
- Replace battery when indication of battery power is insufficient, so as to prevent measurement error.
- Do not use products in the environment of explosive gas, water vapor or dust.
- For actual temperature, please refer to the emissivity information. Reflective objects will cause the measured temperature to be lower than the actual temperature. These objects are dangerous to burn.
- Do not put the thermometer near or put it on a high temperature object
- Please be sure to use the meter according to the regulations, otherwise the protection function provided by the product may be weakened.
- Do not use a solvent cleaning thermometer.

CAUTION!

To avoid damaging the thermometer or the tested equipment, please protect it from the following effects:

- Electromagnetic field and static electricity of arc welding machine, induction heater and other equipment.
- Thermal shock (when a sudden change in ambient temperature occurs, the thermometer must be placed in the environment for 30 minutes to stabilize the thermometer).
- Do not put the thermometer near or put it on a high temperature object.
- Keep the thermometer clean and avoid dust entering the barrel.

OPERATING THERMOMETER

■ ALARM UPPER LIMIT SETTING

- 1- Press "MODE" key and hold for more than 2 seconds. The meter enters the set state.
- 2- Press "MODE" key(≤ 1 Sec.) Switch to alarm upper limit set state, display the "Hi". And display the current alarm upper limit value.
- 3- Press " \blacktriangle / \blacktriangledown " key increase or decrease the set value, press and hold key to increase or decrease the set value quickly.
- 4- Press trigger switch, or press "MODE" key and hold for more than 2seconds, exit settings.

■ ALARM LOW LIMIT SETTING

- 1- Press "MODE" key and hold for more than 2 seconds. The meter enters the set state.
- 2- Press "MODE" key(≤ 1 Sec.) Switch to alarm low limit set state, display the "Low". And display the current alarm low limit value.
- 3- Press " \blacktriangle / \blacktriangledown " key increase or decrease the set value, press and hold key to increase or decrease the set value quickly.
- 4- Press trigger switch, or press "MODE" key and hold for more than 2seconds, exit settings.

■ EMITTANCE SETTING

Press "MODE" key and hold for more than 2 seconds. The meter enters the set state.

Press "MODE" key(≤ 1 Sec.) Switch to emittance set state, Emittance display area scintillation display.

Press " \blacktriangle / \blacktriangledown " key increase or decrease the set value, press and hold key to increase or decrease the set value quickly.



Press trigger switch, or press "MODE" key and hold for more than 2seconds, exit settings.

REFERENCE TABLE OF INFRARED RADIATION

MEASURED SURFACE		RADIATION
ALUMINUM	OXIDIZED	0.2-0.4
	A3003 ALLOY (OXIDIZED)	0.3
	A3003 ALLOY (COARSE)	0.1-0.3
BRASS	POLISHING	0.3
	OXIDIZED	0.5
COPPER	OXIDIZED	0.4-0.8
	ELECTRICAL TERMINAL BOARD	0.6
HASTELLOY		0.3-0.8
FERRO-NICKEL	OXIDIZED	0.7-0.95
	ABRASIVE BLASTING	0.3-0.6
	ELECTROPOLISHING	0.15
IRON	OXIDIZED	0.5-0.9
	RUST	0.5-0.7
IRON (CASTING)	OXIDIZED	0.6-0.95
	UNOXIDIZED	0.2
	FUSION CAST	0.2-0.3
IRON (CASTING) PASSIVATION		0.9
LEAD	COARSE	0.4
	OXIDIZED	0.2-0.6
MOLYBDENUM OXIDATION		0.2-0.6
NICKEL OXIDATION		0.2-0.5
PLATINUM BLACK		0.9
STEEL	COLD ROLLING	0.7-0.9
	GRINDING STEEL PLATE	0.4-0.6
	POLISHED STEEL PLATE	0.1
ZINC	OXIDIZED	0.1
ASBESTOS		0.95
ASPHALT		0.95
BASALT		0.7
CARBON (UNOXIDIZED)		0.8-0.9
GRAPHITE		0.7-0.8

SILICON CARBIDE	0.9
CERAMICS	0.95
CLAY	0.95
CONCRETE	0.95
CLOTH	0.95
GLASS PLATE	0.85
GRAVEL	0.95
PLASTER	0.8-0.95
ICE	0.98
LIMESTONE	0.98
PAPER	0.95
PLASTICS	0.95
SOIL	0.9-0.98
WATER	0.93
TIMBER	0.9-0.95

LASER ON OR OFF

In the measurement mode, press "  " key (≤ 1 Sec.) to turn on laser, press again to turn off laser. When laser turn on, LCD display "  ".

TEMPERATURE UNIT SETTING

In the measurement mode, press and hold the °C/°F key (≤ 1 Sec.) to convert the temperature units.

NON-CONTACT TEMPERATURE MEASUREMENT

Aim at the measured object with the thermometer and pull the trigger to keep the temperature continuously measured. Loosen the trigger and keep the result of the measurement. When measuring, a laser pointer can be used to help the thermometer aim.

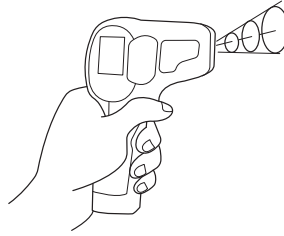

Maximum value of the meter shows the maximum value of the measurement temperature.

When the measured value is greater than the set upper temperature alarm value or the measured value is less than the set lower temperature alarm value, the instrument alarm indicator lights red and displays "Hi" or "Low" characters.

⚠ NOTE!

- Attention should be paid to distance and spot diameter ratio and field of view (see target distance ratio).
- Laser is used only for aim and is independent of temperature measurement.
- After 30 seconds without any operation, the thermometer will be turned off automatically. If you need to start a thermometer, pull the trigger.

TARGET DISTANCE RATIO (D:S RATIO)

The thermometer has a certain angle of view and field of view, as shown in the following figure.

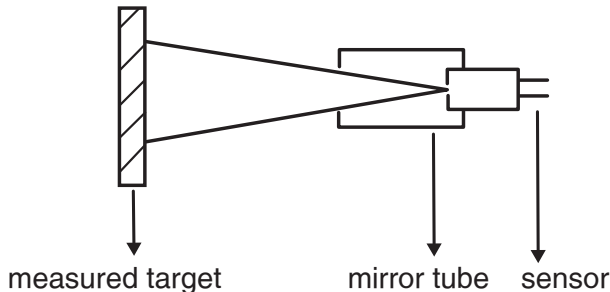

Make sure the object under test is full of the field of view of the thermometer, that is, let the thermometer "see" only the object under test and "not see" other objects. The larger the object is, the farther the distance can be measured; the smaller the object, the closer the distance must be. The ratio of the measured distance to the measured target size is D:S ratio of 12: 1, as shown in the following figure

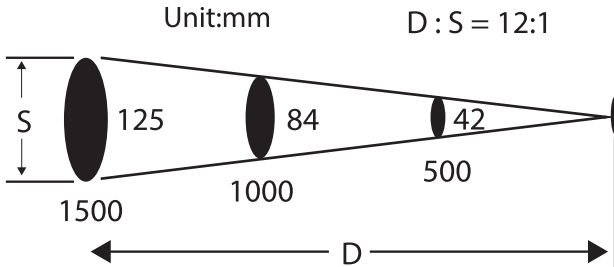

INFRARED RADIATION RATE OF OBJECT

The radiant rate represents the ability of an object to radiate infrared radiation. The greater the radiation rate, the stronger the radiation ability of the object surface. The emissivity of most organic or metal oxide surfaces is between 0.85-0.98. The emissivity of the thermometer is 0.95. The emissivity of the instrument should be consistent with the emissivity of the measured object when measuring. Attention should be paid to the effect of radiation on measurement results.

REPLACE THE BATTERY

Batteries contain dangerous chemicals that may cause burns or explosions. If you are exposed to chemicals, wash or seek medical advice with water. To prevent injury and ensure safety work and maintenance.

- Do not disassemble the battery.
- If battery leakage occurs, please repair it and use it first.
- If the meter is not used for a long time, please remove the battery to

prevent the battery from leaking and damage the instrument.

- Please make sure that the battery is correct in order to prevent the battery leakage.
- Do not connect the battery terminals together. Do not disconnect or squeeze the battery.
- Do not store batteries in containers that may cause short circuit terminals.
- Do not place the battery near the heat source or the fire source. Do not shine under the sun.

When the battery power is insufficient, the meter displays the "🔋" symbol and the battery must be replaced at this time. Open the battery cover with your hands, replace the new battery with the same specifications, and then close the battery cover tightly. As shown.

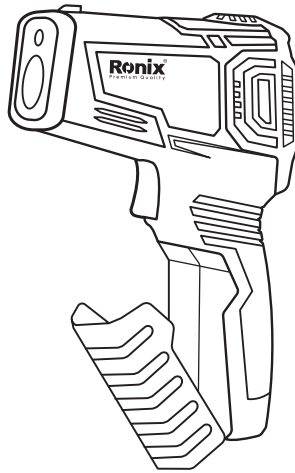

CLEAN LENS TUBE

Use clean air to remove dust particles from the lens barrel. Carefully wipe the surface with a cotton swab dipped in water.

SURFACE CLEAN

Wet the sponge or soft cloth with soap and water. Do not use abrasives or solvents.

Ronix[®]
Premium Quality

www-ronixtools.com