

Ronix[®]

Premium Quality

3D LASER LEVEL

RH-9537

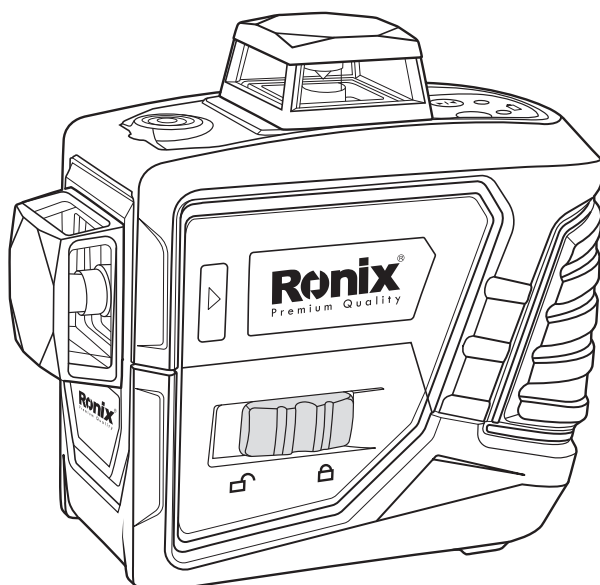

SPECIFICATIONS

Includes	li-ion battery. -Alkaline battery -Charge box -Charger -Laser plate -Goggle. - bracket.
Resistant to	Water and Dust (IP54)
Operating Temperature	10 to 50
Continuous Working Time (All Diodes)	15hour
Tripod Thread	1/4" & 5/8"
Laser Width	3.5mm @10m
Model	RH-9537
Laser Type	660nm, laser class II
Power Supply	Li-ion battery 2600 mAh 7.4V or 4*AA alkaline battery pack
Dimensions	132x85x127 mm3
Leveling Range	±3°
Working Range/With Detector	15m/70m with laser receiver
Accuracy of V&H line	±2mm @5m
Net Weight	675GR
Supplied in	BMC

HOW TO OPERATE THE UNIT?

■RIGHT SIDE : PENDULUM LOCK

The 3D cross line laser is a precision instrument and should be treated with care.

When not in use, the pendulum should always be in the lock position (figure 1)
To lock the pendulum allows the cross line laser to better withstand vibration and trauma incurred during transportation or if the unit is dropped

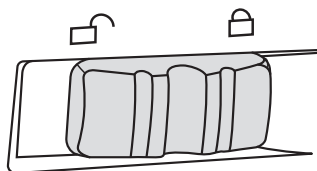

Figure 1

■ LEFT SIDE – AUTOMATIC LEVELING

When the pendulum is unlocked (figure2) the pendulum is free to automatically level, in order for the cross line laser to automatically level, the base of the unit needs to be within 5° of level.

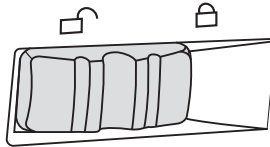
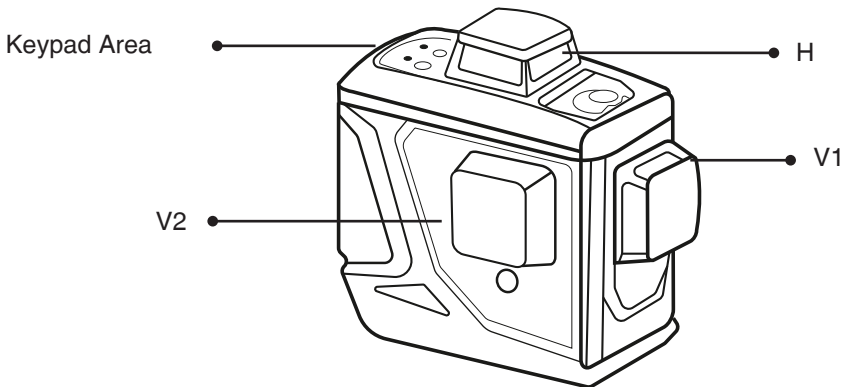
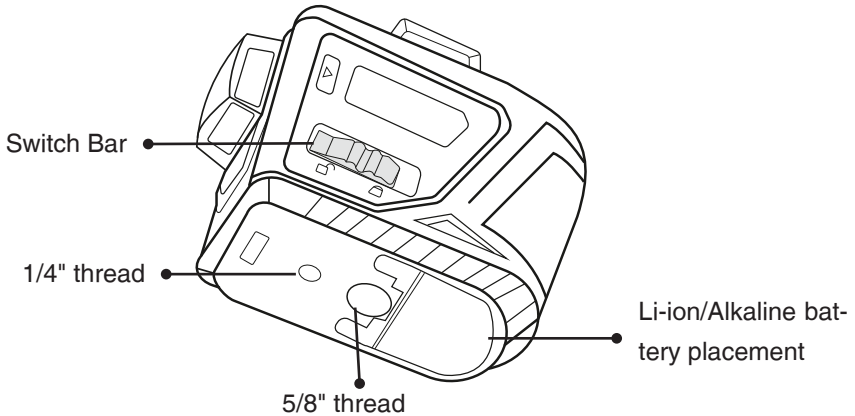
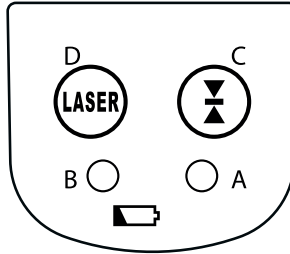

Figure 2



KEYPAD



■A-PLUS INDICATOR

■B- PULSE BUTTON

When pulse is on, this indicator A will turn to red, at this moment laser line can be pick up by laser receiver. Press this key C again to turn off the pulse function and the light will be off.

■C- POWER INDICATOR

When switch on the laser the power indicator will be in continuous light up.

When voltage low, the indicator will link wink slowly.

When voltage turns to flat, the indicator will start to wink quickly before the lase shut off automatically.

■D- LINE SELECTION

Ine selection: by pressing line selection button at the keypad panel can make a various change/collocation of laser lines. The sequence of it is as below:

■H-TURN ON WHEN LASER IS SWITCHED ON

-Press line button for 1 time, V1 on, V2 and H off.

-Press line button for 2nd time, V2 on, V1 and H off.

-Press line button for 3rd time, V1 & V2 on, H off.

-Press line button for 4th time, all V1, V2 and H on.

-Press line button for 5th time, H on, V1 and V2 off (same to the first step.)

BATTERY

■ THIS DEVICE CAN BE USED FOR AA ALKALINE BATTERIES(1.5V) AND LITHIUM BATTERIES.

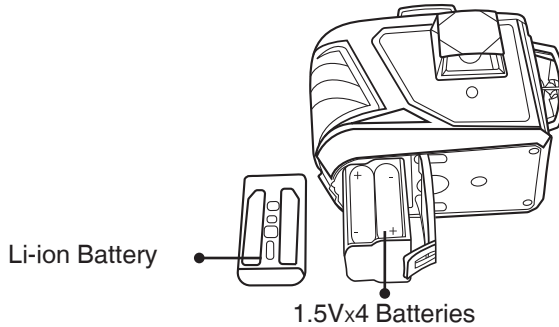

CHARGER

Lithium battery can be charged when not use. Put it onto the charge box that comes with the kit and connect it with power adaptor to charge the battery.

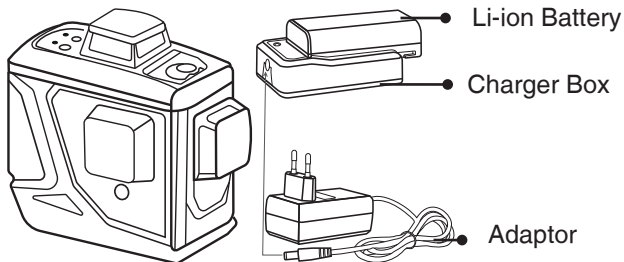

Time to full charge the battery:3-4 hours

Battery capacity:1500mAh.

LED indicator at charge box:

RED: in charging green: full charged. Winking with red: wrong connecting.

BENEFIT FEATURE

■ LOCK EMITTING

When our 3D laser is in the mode of pendulum lock (switch bar at the right side)

By pressing/holding line selection botton for 3 seconds to activate lock emitting mod.

Line will come out from laser but be aware at this mode the laser itself is out of accuracy as the pendulum is locked. Lase at this moment can be used for some “special “application such as stairs alignment since the pendulum is locking.

LINE ALARM WHEN AT LOCK EMITTING MODE

Laser line will flash for every 5 seconds to notice user that the laser is out of accuracy.

ALARM FUNCTION

■ OUT LEVEL ALARM

When the pendulum is unlocked and the cross line laser is within 3.5° of level, the unit will be automatic leveling range, in this situation no LED light will be on. When the base of the unit locates outside the 3.5° leveling range the laser beam will flash meanwhile an audibly warning will be sent out form cross line laser

LOW BATTERY ALARM

The green battery LED will be on and keep flashing slowly when the working voltage is lower that the set data. At this situation the batteries are required to be charged.

Ronix[®]
Premium Quality