

Ronix[®]

Premium Quality

LASER LEVEL WITH PLUMBING DOT RH-9504



www.ronixtools.com



SPECIFICATIONS

Model	RH-9504
Accuracy	±2mm/5m
Leveling Range	±3°
Working Range/ with Detector	15m & 50m(with detector)
Tripod Thread	¼"
Laser Type	laser class II
Operating Temperature	-10 to 45°
wavelength	638nm
Dimension	115×77×120/mm
Continuous Working Time	>8 hour
Protection Class Spray Water/ Dust	IP54
Power Supply	4×AA alkaline batteries 6v
Net Weight	510gr

PARTS LIST

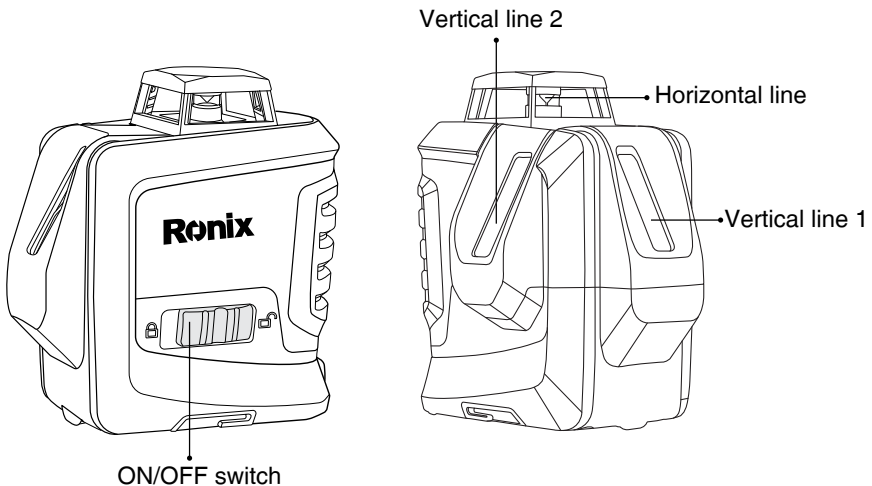

HOW TO OPERATE THE UNIT?

■ RIGHT SIDE: PENDULUM LOCK

The laser level with plumbing Dot is a precision instrument and should be treated with care.

When not in use, the pendulum should always be in the OFF position To lock the pendulum allows the cross line laser to better withstand vibration and trauma incurred during transportation or if the unit is dropped

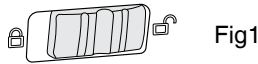

Fig1

■ LEFT SIDE – AUTOMATIC LEVELING

When the pendulum is unlocked (figure2) the pendulum is free to automatically level, in order for the cross line laser to automatically level, the base of the unit needs to be within 3° of level.

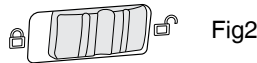
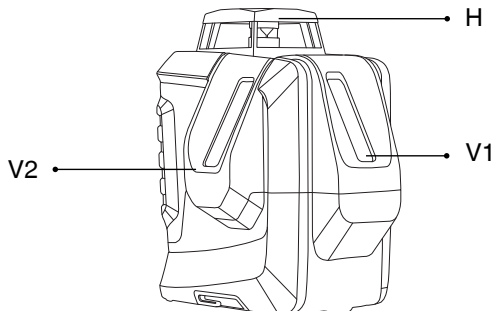
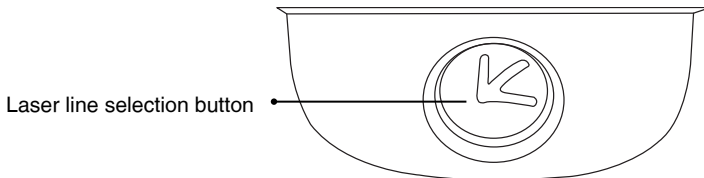

Fig2



KEYPAD

■ TURN ON WHEN LASER IS SWITCHED ON

- Press line button for 1 time, V on, V2 and H off.
- Press line button for 2nd time, V2 and V1 on, and H off.
- Press line button for 3th time, all V1, V2 and H on.

BATTERY

- This device can be used for AA alkaline batteries(6V)

Ronix[®]
Premium Quality

www.ronixtools.com