

**Ronix**<sup>®</sup>  
Premium Quality

**PALLET TRUCK**  
**RH-4980**

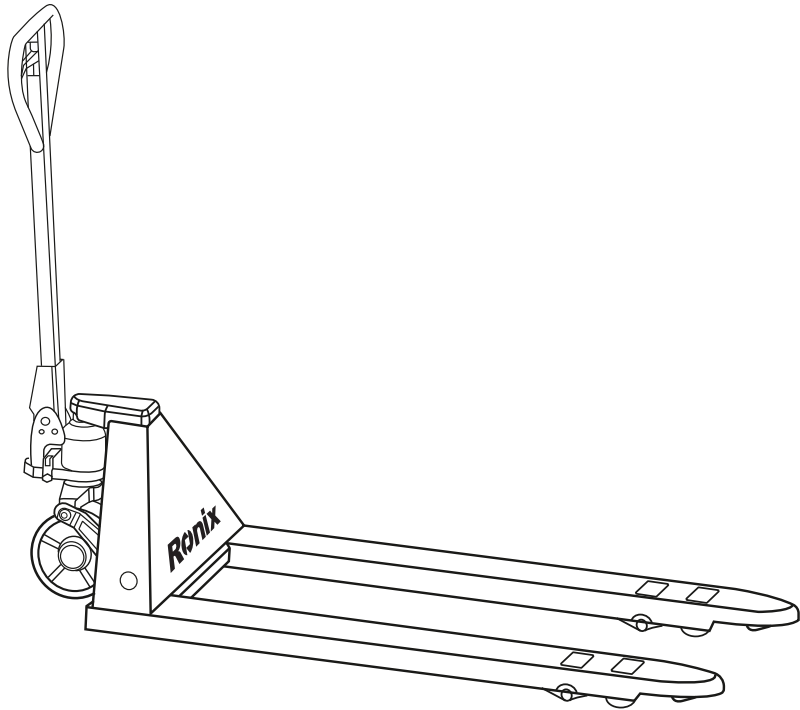



## TECHNICAL SPECIFICATION

Model	<b>RH-4980</b>
Capacity	3000Kg
Min Fork Height	75mm
Max Fork Height	190mm
Size Of Fork	150×50mm
Fork Width	550mm
Fork Length	1150mm
Wheel Diameter	74mm/180mm
Fok Material	Q235 3.5mm
Body Material	Q235 3.5mm
Wheel Material	NYLON
Length Of Handle	863mm
Weight	66Kg
Supplied In	6pcs/Wooden Pallet

## PART LIST

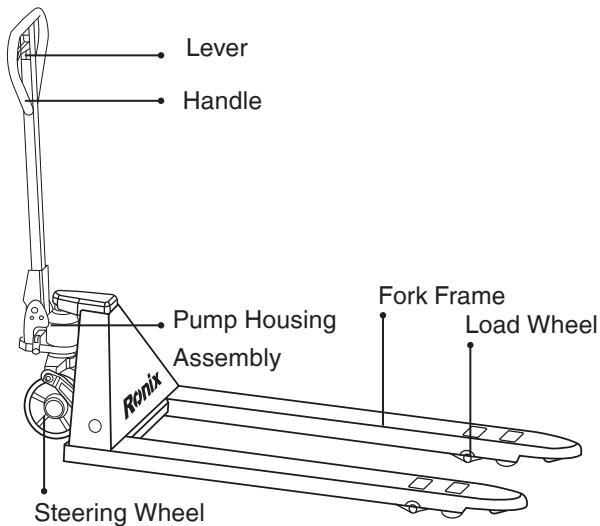

## **⚠ WARNING!**

The use of the pallet truck, maintenance and repair must be done in accordance with the requirements of the manufacturers. Prohibits any modification or installed on attachments, to ensure that the pallet truck is safe.

### **■ RANGE OF APPLICATION**

- Pallet truck have steady lifting, manipulation of portable, safe and reliable, etc.
- Ground: rough, hard, level and no holes and obstacles.

### **■ SETUP AND ASSEMBLY**

- Insert the base of the handle into the pump bracket.
- Align the holes at the base of the handle with the holes in the pump bracket.
- Using a screwdriver, pry the cam up and slip the cam net under the notch in the cam.
- Insert handle pins into the holes of the pump bracket and handle. Align the spring pin holes in the handle pin and the pump bracket.
- Tap the handle pins into place with a hammer.
- Using a hammer, tap the spring pins into the pump bracket and handle pins.

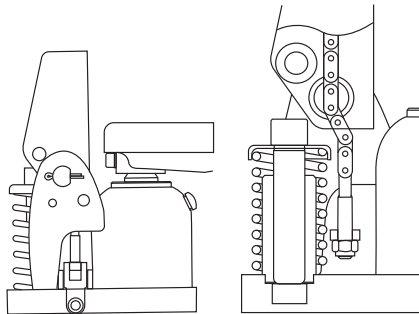

### **■ OPERATIONS**

- To raise forks, place handle in the UP position.

- To lower forks, pull lever handle to DOWN position (upper part of slot).
- To freely move the handle, set lever in Neutral (center notch of slot).
- The cam nut is properly adjusted when pumping the handle in NEUTRAL position causes no movement of the hydraulic ram.

## ■ INTRODUCTION

To better understand the proper use and safe operation of this pallet truck, please take a few minutes to carefully read and follow the instructions contained in this manual. When finished reading and understanding the manual, please file in a safe and convenient location for the life of the pallet truck. If the pallet truck transfers ownership, the manual should accompany it.

This pallet truck is designed to push and pull palletized material loads up to 3000 kilogram only.

You will notice several important features about your WDFE Pallet Truck. For example, the heavy gauge steel frame is reinforced with cross welded steel plates to prevent forks from bending and solid steel push rods are used for added strength.

The pump features top of the stroke and overload by-pass valve systems. A durable powder coat finish provides long lasting steel protection. Extra wide polyurethane covered steel steer wheels and nylon load wheels feature lifetime lubricated, double sealed bearings to provide smooth, quiet rolling and added stability.

## ■ SAFETY WARNINGS

- Read and understand the entire owner's manual before attempting assembly or operation of the pallet truck.
- Read and understand the warnings on the pallet truck and in this manual.

Failure to comply with all of these warnings may cause serious injury.

- Replace the warning labels if they become obscured or removed.
- Do not use this pallet truck for other than its intended use. If used

for other purposes, factory, disclaims any real or implied warranty and holds itself harmless from any injury that may result from that use.

- Do not place hands or feet under the pallet truck at any time.
- Do not operate a loaded pallet truck on ramps or inclines.
- Do not tip load pallet truck forks. This may cause damage to the forks and personal injury if the rear of the pallet truck suddenly pops up.
- Never leave a loaded pallet truck unattended in the raised position.

Always lower load to the floor.

- Do not load pallet truck beyond its rated capacity of 3000 Kilogram. Secure load before transporting.
- To prevent accidental tipping, make sure load is centered on the forks.
- Do not move a loaded pallet truck by other than manual force.

#### ■ **CLEANING RELEASE VALVE**

- Over time, the hydraulic pump assembly may become clogged with debris or air bubbles, and not function properly.

#### ■ **TO CLEAN THE RELEASE VALVE AND BLEED THE PUMP:**

- Pump handle quickly, raising pallet truck to full extent. While continuing pumping action, pull lever to down position.
- When forks reach total down position, valve is flushed. Repeat if necessary.

#### ■ **LUBRICATION**

Check oil level annually by removing oil plug found on top of pump housing. When changing or adding oil, fill the tank through the oil plug screw hole to 80% capacity with hydraulic jack oil, about 2" deep in pump housing. Do not use any other type of oil.

## TROUBLESHOOTING THE WDFE SERIES PALLET TRUCKS

SYMPTOM	POSSIBLE CAUSE	CORRECTION
Hydraulic unit does not lift .	1- Oil low in tank. 2- Air in pump. 3- Worn O ring in cylinder.	Hydraulic unit does not lift .
Once lifted, truck lowers by itself.	1- Steel ball not seated inhydraulic unit. 2- Worn O-ring in cylinder. 3- Release valve not seated properly. 4- Oil leakage from Release Plug .	1- Refer to Cleaning Release Valve. 2- Consult authorized service center. 3- Refer to Cleaning Release Valve. 4- Tighten Release Plug Replace O rings on Release Plug. If leakage still occurs, consult authorized service center
Fork does not lower.	1.Cam broken. 2.Up down cam nut out ofadjustment. 3.Broken fork rods andlinkage.	1- Replace cam 2- Refer to section Up-Down Cam Adjustment. 3.Consult authorized service center, or replace broken parts.
Lever does not set at NEUTRAL position.	Up down cam nut out of adjustment.	Refer to Up Down Cam Adjustment.

### ■ WASTE DISPOSAL

Abandoned hydraulic oil can't literally throw, must pay attention to environmental protection, should be dealt with in accordance with local laws and regulations.



[www.ronixtools.com](http://www.ronixtools.com)