

Ronix[®]

Premium Quality

TRANSMISSION JACK 500Kg RH-4943

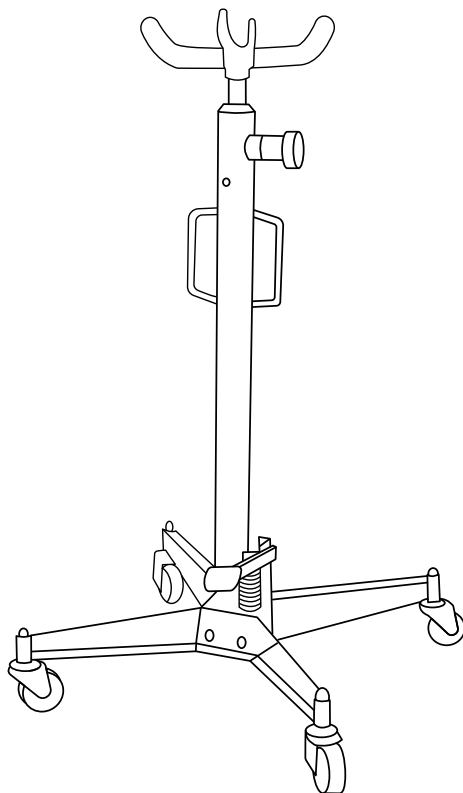

www.ronix.ir



TECHNICAL SPECIFICATION

Model	RH-4943
Load Capacity	0.5T
Maximum Lifting Height	1835mm
Minimum Lifting Height	1100mm
Material	steel
Wheel Material	steel
Wheel Diameter	70mm
Dimensions	630×595×1100mm
Weight	24Kg
Include	Oil Cylinder, Caster, Fork Head, Screw Pack, Pedal, Base

PART LIST

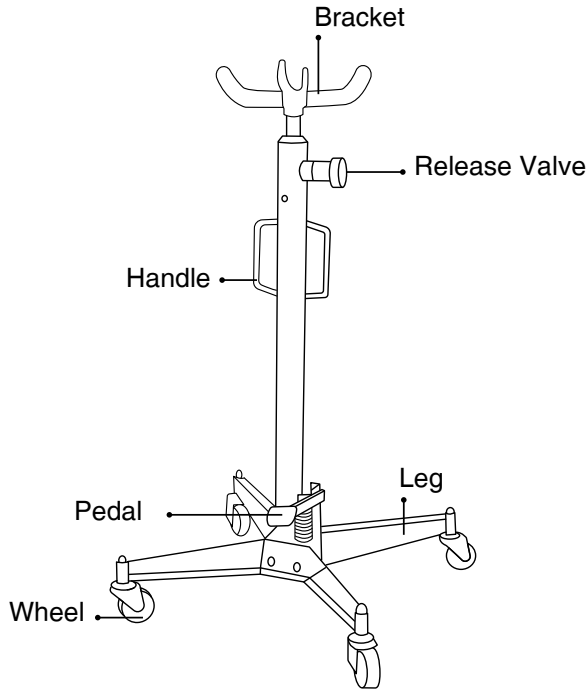

! WARNING!

Read carefully and understand all **ASSEMBLY AND OPERATION INSTRUCTIONS** before operating.

Failure **WARNING!** to follow the safety rules and other basic safety precautions may result in serious personal injury.

SAFETY MARKINGS

! WARNING!

- 1- Study, understand, and follow all instructions before operating this device.
- 2- Do not exceed rated capacity.
- 3- Use only on hard, level surfaces, with less than 3 degrees of slope.

- 4- Adequately support the vehicle before starting repairs.
- 5- Use of this product is limited to the removal, installation, and transportation in the lowered position, of transmissions, transfer cases, and transaxles.
- 6- No alterations shall be made to this product.
- 7- Only attachments and/or adapters supplied by the manufacturer shall be used.
- 8- Do not get under or allow anyone under the vehicle until it has been supported by jack stands.
- 9- Center load on saddle prior to lifting.
- 10- Never use on a lawn mower or lawn tractor.
- 11- Do not use this jack for any use other than the manufacturer specified usage.
- 12- Failure to heed these markings may result in personal injury and/or property damage.

INSPECTION

Inspect the jack carefully before each use. Ensure the jack is not damaged, excessively worn, or missing parts.

- Do not use the jack unless it is properly lubricated.
- Using a jack that is not in good clean working condition or properly lubricated may cause serious injury.
- Inspect the work area before each use. Make sure it is free and clear of any potential hazards. **DO NOT OPERATE OR REPAIR THIS EQUIPMENT WITHOUT READING THIS MANUAL.** To maintain the Transmission Jack and user safety, the owner is responsible for reading and following these instructions.
- Inspect the service jack for proper operation and function.
- Keep instructions readily available for equipment operators. Make certain all equipment operators are properly trained; understand how to safely and correctly operate the unit.
- Allow unit operation only with all parts in place and operating properly.
- Use only genuine replacement parts. Service and maintain the unit

only with authorized or approved replacement parts.

- Carefully inspect the unit on a regular basis and perform all maintenance as required.
- Store these instructions in the handle of your jack. Keep all decals on the unit clean and visible.
- Safety: always follow safety precautions when installing and operating this jack.
- Before proceeding ensure that you fully understand and comprehend the full contents of this manual.
- Failure to operate this equipment as directed may cause injury or death.
- The distributor is not responsible for any damages or injury caused by improper use or neglect.

■ **ALWAYS USE JACK STANDS!**

DO NOT USE wood blocks or any other non-approved load sustaining devices. DO NOT USE wood blocks or any other non approved lifting devices for a means of lifting with the jack and or load being raised.

Failure to heed these warnings may cause injury or death.

■ **MAINTENANCE INSTRUCTIONS**

If you use and maintain your equipment properly, it will give you many years of service. Follow the maintenance instructions carefully to keep your equipment in good working condition. Never perform any maintenance on the equipment while it is under a load.

■ **INSPECTION**

You should inspect the product for damage, wear, broken or missing parts (e.g.: pins) and that all components function before each use. Follow lubrication and storage instructions for optimum product performance.

■ **BINDING**

If the product binds while under a load, use equipment with equal or a larger load capacity to lower the load safely to the ground. After un

binding; clean, lubricate and test that equipment is working properly. Rusty components, dirt, or worn parts can be causes of binding Clean and lubricate the equipment as indicated in the lubrication section. Test the equipment by lifting without a load. If the binding continues contact Customer Service.

■CLEANING

If the moving parts of the equipment are obstructed, use cleaning solvent or another good degreaser to clean the equipment. Remove any existing rust, with a penetrating lubricant.

LUBRICATION

This equipment will not operate safely without proper lubrication. Using the equipment without proper lubrication will result in poor performance and damage to the equipment. Some parts in this equipment are not self-lubricating inspect the equipment before use and lubricate when necessary. After cleaning, lubricate the equipment using light penetrating oil, lubricating spray.

- Use a good lubricant on all moving parts.
- For light duty use lubrication once a month.
- For heavy and constant use lubrication recommended every week.
- NEVER USE SANDPAPER OR ABRASIVE MATERIAL ON THESE SURFACES!

■RUST PREVENTION:

Check rams and pump plungers on the power unit assemblies daily for any signs of rust or corrosion. Without a load lift the equipment as high as it goes and look under and behind the lifting points. If signs of rust are visible clean as needed.

■GREASE FITTINGS

Some models contain grease fittings they will regularly need to be

greased and lubricated.

■ HOW THE JACK OPERATES

With release valve closed, an upward stroke of the jack handle draws oil from the reservoir tank into the plunger cavity. Hydraulic pressure holds the valve closed, which keeps the oil in the plunger cavity.

A downward stroke of the jack handle releases oil into the cylinder, which forces the ram out. This raises the saddle. When the ram reaches maximum extension, oil is bypassed back into the reservoir to prevent an over extended ram stroke and possible damage to the jack. Opening the release valve allows oil to flow back into reservoir. This releases hydraulic pressure on the ram, which results in lowering the saddle.

■ STORING THE JACK

- 1- Lower the hydraulic ram to lowest position.
- 2- Leave lowering valve open.
- 3- Store in a dry location, recommended indoors.

NOTE:

If the jack is stored outdoors, be sure to lubricate all parts before and after use to ensure the jack stays in good working condition. Always store jack in the fully retracted position when stored in outdoor or caustic environments that can cause corrosion and/or rust.

ASSEMBLY INSTRUCTIONS

For easiest transportation the jack is not assembled at the time of purchase. Please refer to the exploded drawing and the instructions below to assemble your new transmission jack stand.

Step 1- The Base

- a- Attach the four ball bearing caster wheels to the 4 respective legs of the jack stand making sure to tighten the screws.
- b- (b) Connect the legs with the bolts and screws provided.

Step 2 - The Cylinder

(a)- Loosen the bolts on the base. Put the cylinder on the right position on the base of the stand and tighten the bolts.

Step 3 - The Saddle

(a)- Slide saddle into the ram.

■ TO USE

(a) To raise the ram simply pump the pedal.

(b) To release turn and hold the release valve counter clock wise.

TROUBLESHOOTING

CAUSES AND SOLUTIONS	WILL NOT LIFT TO FULL EXTENSION	POOR JACK LIFTING	JACK WILL NOT LOWER	JACK WILL NOT HOLD LOAD	JACK WILL NOT LIFT LOAD
Release valve is not completely closed (Turn handle clockwise).		×		×	×
Weight Capacity Exceeded.					×
Air is in the hydraulics. Purge air from system.		×			×
Low oil level. Add oil as required.	×	×		×	×

Oil reservoir is overfilled. Drain excessive oil. Lubricate moving parts.			×		
Jack is binding or foreign obstruction			×		
Power unit malfunctioning. Replace the power unit.		×		×	×

- Safe Operating Temperature is between 40°F – 105°F (4°C -41°C)



www.ronixtools.com