

Ronix[®]

Premium Quality

ENGINE CRANE JACK 2T RH-4942

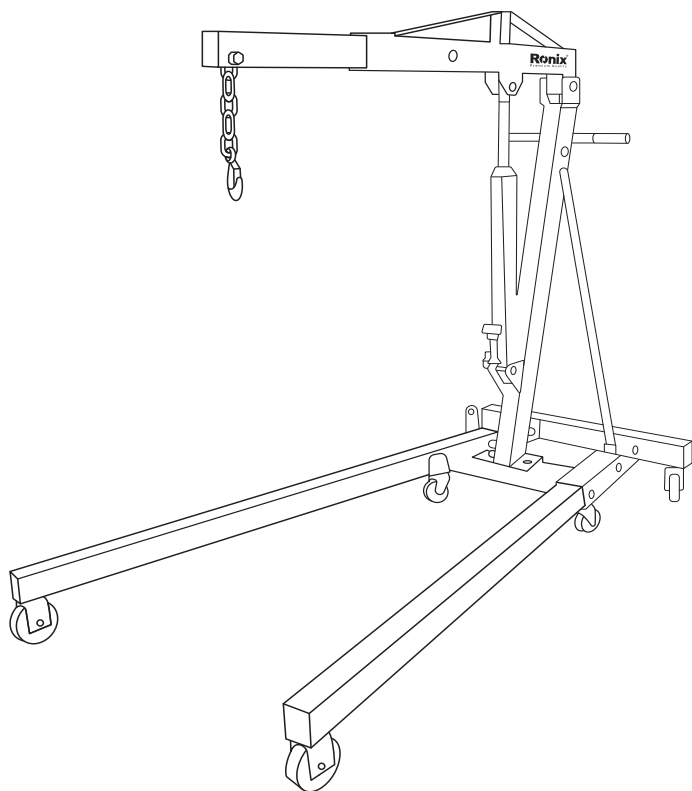

www.ronixtools.com

TECHNICAL SPECIFICATION

Model	RH-4942
Maximum Load	2Ton
Open Height	1530mm
Folded Height	1430mm
Material	Q235
Wheel Material	KTH150-08
Wheel Diameter	3.5",3"
Number Of Loaded Capacity	2Ton,1.5Ton, 1Ton, 0.5Ton
Weight	84Kg

PART LIST

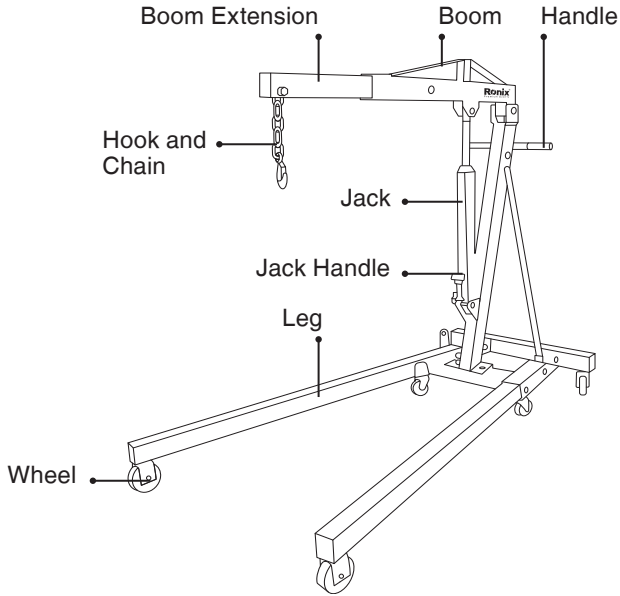

! WARNING!

Read carefully and understand all ASSEMBLY AND OPERATION INSTRUCTIONS before operating.

Failure to follow the safety rules and other basic safety precautions may result in serious personal injury.

Please read these instructions carefully before using the product for the first time and store them for future reference. This product must be operated in accordance with these instructions at all times. Make these instructions for use accessible to all persons who will be working with this product. This applies also when reselling the product. We cannot assume any liability for any accidents or damage that may arise due to non-observance of this guide or the safety instructions contained therein.

WARNING: Lifting of persons prohibited!



General warning sign



Rated capacity
Kgs 2,000



Read the manual instruction before using



Don't stand under the machine to avoid being hit

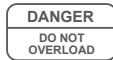

Do not overload



Warning about hand injuries

SPECIFICATION

Always use Engine Crane!

Always follow safety precautions when installing and operating this equipment. Keep all decals on the unit clean and visible.

Before proceeding ensure that you fully understand and comprehend the full contents of this manual. Failure to operate this equipment as directed may cause injury or death. The distributor is not responsible for any damages or injury caused by improper use or neglect.



INSPECTION

- Inspect the equipment carefully before each use. Ensure the equipment is not damaged, excessively worn, or missing parts.
- Do not use the equipment unless it is properly lubricated.
- Using equipment that is not in good clean working condition or properly lubricated may cause serious injury.
- Inspect the work area before each use. Make sure it is free and clear of any potential hazards. **DO NOT OPERATE OR REPAIR THIS**

EQUIPMENT WITHOUT READING THIS MANUAL. To maintain the equipment and user safety, the responsibility of the owner is to read and follow these instructions.

- Inspect the equipment for proper operation and function.
- Keep instructions readily available for equipment operators.
- Make certain all equipment operators are properly trained; understand how to safely and correctly operate the unit.
- Allow unit operation only with all parts in place and operating properly.
- Use only genuine replacement parts.
- Service and maintain the unit only with authorized or approved replacement parts.
- Carefully inspect the unit on a regular basis and perform all maintenance as required.
- Store these instructions in the handle of your equipment.
- Keep all decals on the unit clean and visible.

 **WARNING!**

- 1- Study, understand, and follow all instructions before operating this device.
- 2- Do not exceed rated capacity.
- 3- Use only on hard, level surfaces, with less than 3 degrees of slope.
- 4- Before moving, lower the load to the lowest possible point.
- 5- Use only slings or chains with a rated capacity greater than the weight of the load being lifted.
- 6- Do not allow load to swing or drop violently while lowering or moving.
- 7- Center load prior to lifting.
- 8- No alterations shall be made to this product.
- 9- Make sure that boom is fully lowered before adding oil to unit reservoir.
- 10- Never use on a lawn mower or lawn tractor.
- 11- Do not rock the vehicle while working on or around equipment.
- 12- Equipment is design for lifting only, do not move or dolly crane when in use.

13- The following are not recommended for supporting on this equipment: Foundations, Homes, Mobile Homes, Trailers, RV's, Campers, nor Fifth Wheels, etc...

14- Do not use this crane for any use other than the manufacturer specified usage.

15- Failure to heed these markings may result in personal injury and/or property damage.

■ MAINTENANCE

Monthly maintenance is recommended. Lubrication is critical to jacks as they support heavy loads. Any restriction due to dirt, rust, etc., can cause either slow movement or cause extremely rapid jerks, damaging the internal components. The following steps are designed to keep the jack well lubricated:

1- Lubricate the ram, linkages, saddle and pump mechanism with light oil. Grease wheel bearings and axles.

2- Visually inspect for cracked welds, bent, loose, missing parts or hydraulic oil leaks.

3- If jack is subjected to abnormal load or shock, remove from service and have it examined by a customer service representative prior to use.

4- Clean all surfaces and maintain all labels and warnings.

5- Check and maintain the ram oil level. 6. Check ram every 3 months for any sign of rust or corrosion. Clean as needed and wipe with an oil cloth.

When not in use, always leave the saddle and ram all the way down.

Always store your jack in the fully lowered position. this will help protect critical areas from excessive corrosion. Do not use brake or transmission fluids or regular motor oil as they can damage the seals. Always purchase and use products labeled Hydraulic Jack Oil.

TROUBLESHOOTING

Causes And Solutions	Will Not Lift To Full Extension	Poor Jack Lifting	Jack Will Not Lower	Jack Will Not Hold Load	Jack Will Not Lift Load
Release Valve Is Not Completely Closed (Turn Handle) (Clockwise).		X		X	X
Weight Capacity Exceeded.					X
Air is in the hydraulics. Purge air from system.		X			X
Low oil level. Add oil as required.	X	X		X	X
Oil reservoir is overfilled. Drain excessive oil. Lubricate moving parts.			X		
Jack is binding or foreign obstruction			X		
Power unit malfunctioning. Replace the power unit.		X		X	X

Safe Operating Temperature is between -20°C – 50°C

MAINTENANCE INSTRUCTIONS

If you use and maintain your equipment properly, it will give you many years of service. Follow the maintenance instructions carefully to keep your equipment in good working condition. Never perform any maintenance on the equipment while it is under a load.

■ INSPECTION

You should inspect the product for damage, wear, broken or missing parts (e.g.: pins) and that all components function before each use. Follow lubrication and storage instructions for optimum product performance.

■ BINDING

If the product binds while under a load, use equipment with equal or a larger load capacity to lower the load safely to the ground. After

un-binding; clean, lubricate and test that equipment is working properly. Rusty components, dirt, or worn parts can be causes of binding Clean and lubricate the equipment as indicated in the lubrication section. Test the equipment by lifting without a load. If the binding continues contact Customer Service.

■CLEANING

If the moving parts of the equipment are obstructed, use cleaning solvent or another good degreaser to clean the equipment. Remove any existing rust, with a penetrating lubricant.

■LUBRICATION

This equipment will not operate safely without proper lubrication. Using the equipment without proper lubrication will result in poor performance and damage to the equipment. Some parts in this equipment are not self-lubricating inspect the equipment before use and lubricate when necessary. After cleaning, lubricate the equipment using light penetrating oil, lubricating spray.

Use a good lubricant on all moving parts.

For light duty applications, use lubrication once a month.

For heavy and constant application, weekly lubrication is recommended.

NEVER USE SANDPAPER OR ABRASIVE MATERIAL ON THESE SURFACES!

■RUST PREVENTION:

Check rams and pump plungers on the power unit assemblies daily for any signs of rust or corrosion. Without a load, lift the equipment as high as it goes and look under and behind the lifting points. If signs of rust are visible, clean as needed.

■HOW THE LONG RAM OPERATES

With release valve closed, an upward stroke of the long ram handle draws oil from the reservoir tank into the plunger cavity. Hydraulic

pressure holds the valve closed, which keeps the oil in the plunger cavity. A downward stroke of the long ram handle releases oil into the cylinder, which forces the ram out. This raises the hydraulic ram. When the ram reaches maximum extension, oil is bypassed back into the reservoir to prevent an over extended ram stroke and possible damage to the long ram. Opening the release valve allows oil to flow back into reservoir. This releases hydraulic pressure on the ram, which results in lowering the hydraulic ram.

■ **STORING THE CRANE**

1- Lower the Lifting Arm.

2- Place the handle in the upright position.

3 -Store in a dry location, recommended indoors

Note: If the crane is stored outdoors, be sure to lubricate all parts before and after use to ensure the crane stays in good working condition.

■ **FACTORY PRODUCT**

Any equipment found to be damaged in any way, is found to be worn or operates abnormally, believed to have subjected to an abnormal load. **SHALL BE REMOVED FROM SERVICE UNTIL REPAIRED.** Owners and/or operators should be aware that repair of the equipment requires specialized knowledge and facilities.

Only factory authorized parts, labels and decals shall be use on this equipment. Annual inspection of the is recommended and should be made by the manufacturer's authorized repair facility to ensure that your jack is in optimum conditions and that the jack has correct decals and safety labels specified by the manufacturer.



www.ronixtools.com