

Ronix®

Premium Quality

DIE 3 - TONNEN-ACHSSTÄNDER RH-4941

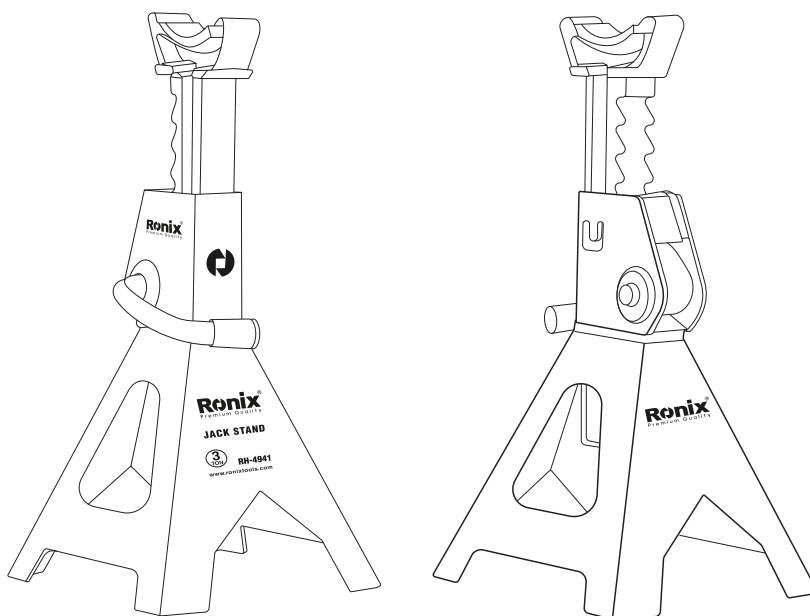

www.ronixtools.com



TECHNISCHE DATEN

Modell	RH-4941
Tragkapazität	3TON
Material	Kombination von Gusseisen und Stahl
Verriegelungstyp	Ratschenmechanismus
Min Höhe	285mm
Max Höhe	425mm
Standards	ASME
Gewicht	6.3Kg

GERÄTEKOMPONENTEN

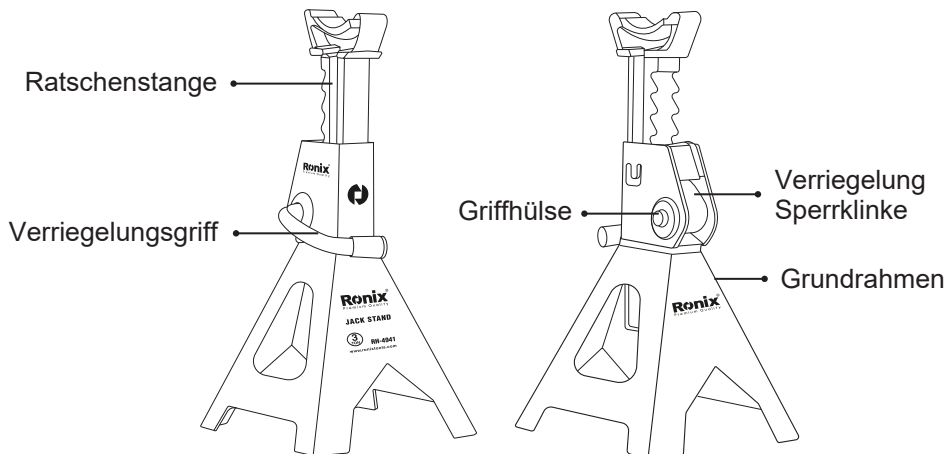

SICHERHEITSANWEISUNGEN

- 1- Lesen, verstehen und befolgen Sie alle Anweisungen, bevor Sie dieses Gerät verwenden.
- 2- Überschreiten Sie nicht die bewertete Kapazität.
- 3- Verwenden Sie den Wagenheber nur auf harten, ebenen Oberflächen mit weniger als 3 Grad Neigung.
- 4- Zentrieren Sie die Last auf dem Sattel.
- 5- Verwenden Sie nur ein passendes Paar.
- 6- Verwenden Sie die Stützen nicht gleichzeitig an beiden Enden eines Fahrzeugs.
- 7- Keine Änderungen am Produkt vornehmen.
- 8- Stützen Sie nur die Bereiche des Fahrzeugs ab, die von Fahrzeughersteller angegeben sind.
- 9- Verwenden Sie nur vom Hersteller gelieferte Anbaugeräte und/oder Adapter.
- 10- Verwenden Sie Radkeile oder andere Blockiergeräte an den gegenüberliegenden Rädern, bevor Sie Wagenheberstützen verwenden.
- 11- Verwenden Sie Wagenheberstützen nur für den vom Hersteller vorgesehenen Zweck.
- 12- Verwenden Sie das Produkt nicht, wenn es beschädigt ist.
- 13- Verwenden Sie Wagenheberstützen NIEMALS an Rasenmähern oder Rasentraktoren.
- 14- Bewegen Sie das Fahrzeug nicht, solange es auf den Stützen steht.
- 15- Bewegen Sie das Fahrzeug nicht, während Sie daran arbeiten oder sich in der Nähe von Ausrüstung befinden.
- 16- Die folgenden Anwendungen werden auf diesem Gerät nicht empfohlen: Fundamente, Häuser, Mobilheime, Anhänger, in Wohnmobile, Wohnwagen usw.
- 17- Nichtbefolgung dieser Markierungen kann zu persönlichen Verletzungen und/oder Sachschäden führen.

Ronix®

Premium Quality

3TON JACK STAND RH-4941

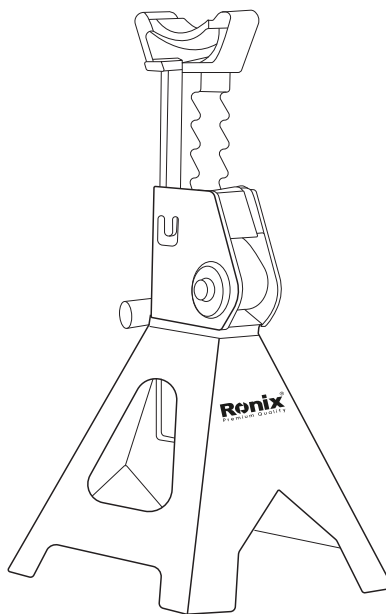
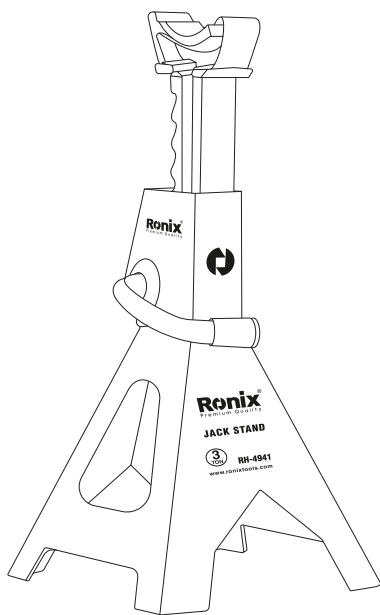

TECHNICAL SPECIFICATIONS

Model	RH-4941
Capacity	3TON
Material	Cast iron/steel
Lock Type	Locking Pawl
Min. Height	285mm
Max. Height	425mm
Standards	ASME
Weight	6.3Kg

PART LIST

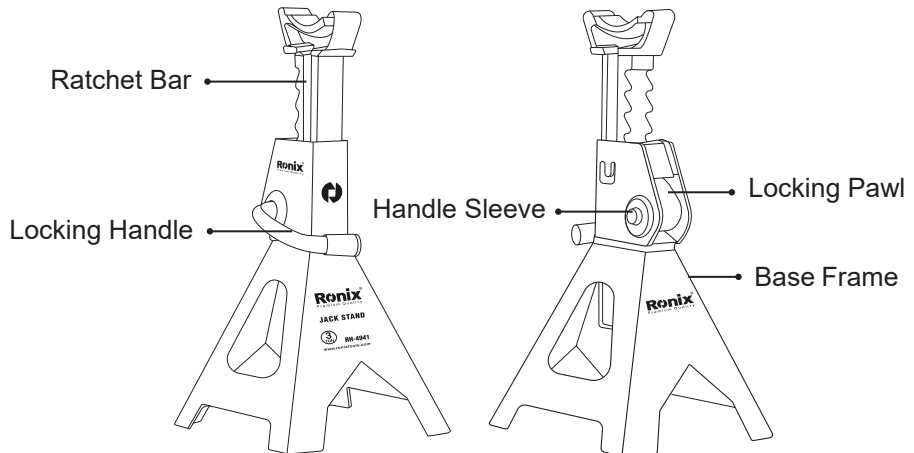

SAFETY INSTRUCTIONS

- 1- Study, understand, and follow all instructions before operating this device.
- 2- Do not exceed rated capacity.
- 3- Use only on hard, level surfaces, with less than 3 degrees of slope.
- 4- Center load on saddle.
- 5- Use as a matched pair only.
- 6- Stands are not to be used to simultaneously support both ends of a vehicle.
- 7- No alterations shall be made to this product.
- 8- Support only on areas of the vehicle as specified by the vehicle manufacturer.
- 9- Only attachments and/or adapters supplied by the manufacturer shall be used.
- 10- Use wheel chocks or other blocking device on opposing wheels before using jack stands.
- 11- Do not use jack stands for any use other than the manufacturer specified usage.
- 12- Do not use if damaged in any way.
- 13- NEVER use jack stands on a lawn mower or lawn tractor.
- 14- Do not move or dolly the vehicle while on support stands.
- 15- Do not rock the vehicle while working on or around equipment.
- 16- The following are not recommended for supporting on this equipment: Foundations, Homes, Mobile Homes, Trailers, RV's, Campers, nor Fifth Wheels, etc...
- 17- Failure to heed these markings may result in personal injury and/or property damage.

OPERATION

- 1- Put the jack stands on hard level ground Adjust height by pulling up on ratchet.

- 2- Place load on the center of saddle for safety it is strongly recommended that lifting means not be removed while jack stands are supporting the vehicle.
- 3- Secure ratchet by turning stopper to hold load. Make sure stopper has been securely inserted. Release stopper and let ratchet glide down to the lowest position when storing the jack stand.
- 4- Read the instruction manual completely and keep it for further information purpose.
- 5- secure lifted loads with jack stands immediately
- 6- If the operator is not fluent in English, the product and safety instructions shall be read to and discussed with the operator in the operator's native language by the purchaser/owner or his designee, making sure that the operator comprehends their contents.
- 7- Inspect before each use **DO NOT USE IF BENT BROKEN OR CRACKED COMPONENT ARE**
- 8- **NOTED.** prevent corrosion. Clean as needed and wipe with an oily cloth and keep in dry area when not in use.

Some Models May Have Screw
Rather Than a Metal Tab

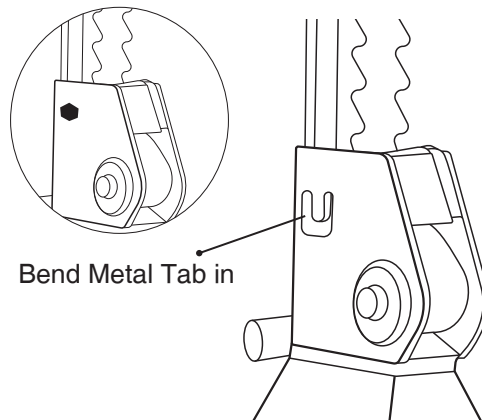

Visual inspection shall be performed before each use of the stand by checking abnormal condition, such as cracked welds, leaks and damaged, loose, or, missing parts if stand is believed to have been subjected to abnormal load or shock inspection shall be made by authorized repair facility.

Equipment that appears damage or worn or operates abnormally shall be removed from service until repair. Repair should be made by authorized repair facility.

Annual inspection of the stand is recommended and should be made by the manufacturers or supplier's authorized repair facility to ensure that you stand is optimum conditions and that the stand has correct decals and safety labels specified by the manufacturer.

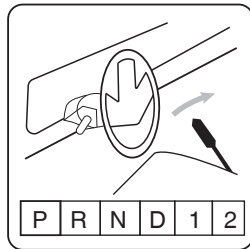

Stop the car

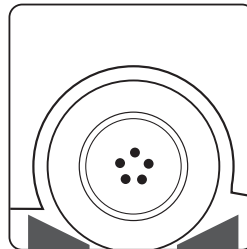

Use wheel chocks to secure the wheel

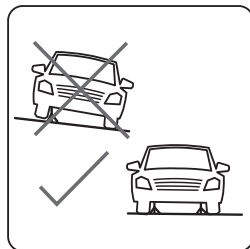

Use the jack stands on even ground

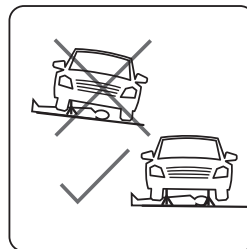

work under the vehicle with jack stands

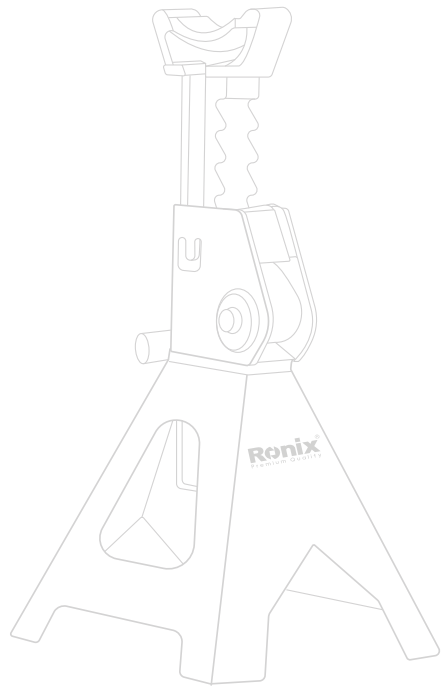
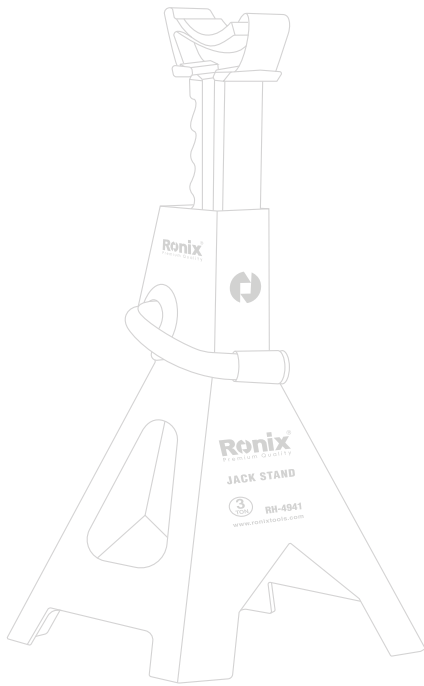





www.ronixtools.com