

Ronix[®]

Premium Quality

COMPACT INVERTER GENERATOR 6000W RH-4772

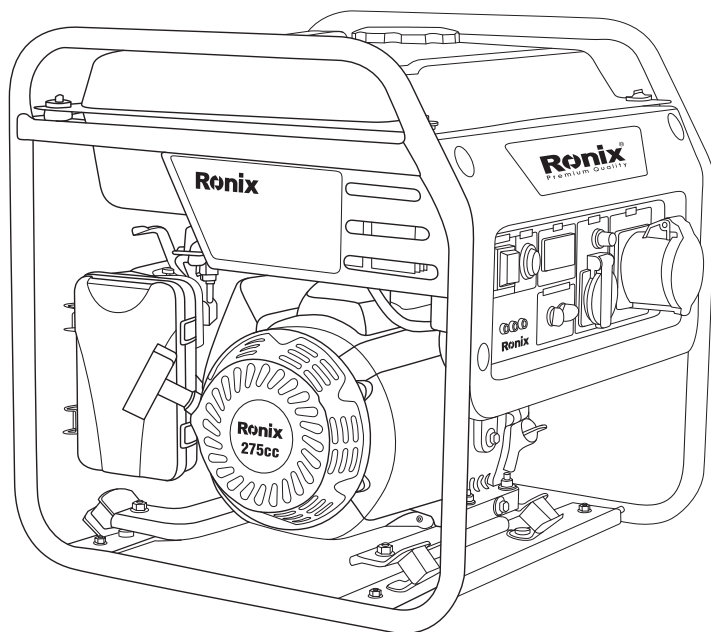

TECHNICAL SPECIFICATION

| | | |
|-------------|--|-------------------------------|
| Model | RH-4772 | |
| Engine | Type | 275F |
| | Displacement | 275CC |
| | Rated Power | 13HP |
| | Ignition System | T.C.I |
| | Start Type | Hand Start |
| | Fuel Tank Capacity | 15L |
| | Continuous Working | 7h |
| | Fuel Type | gasoline |
| Generator | Type | Open frame inverter generator |
| | Rated Voltage | 230V |
| | Frequency | 50Hz |
| | Winding Material | Copper wire |
| | Rated Amperage | 21A |
| | Rated Power | 5000W |
| | Max Power | 6000W |
| Weight | 35Kg | |
| Packaging | Five Layers Bc Corrugated Pape, Normal Carton, Added The Inner 25mm Honeycomb Panels | |
| Accessories | Spark Plug Tool(1Pc), Plug (2Pcs) | |

PART LIST

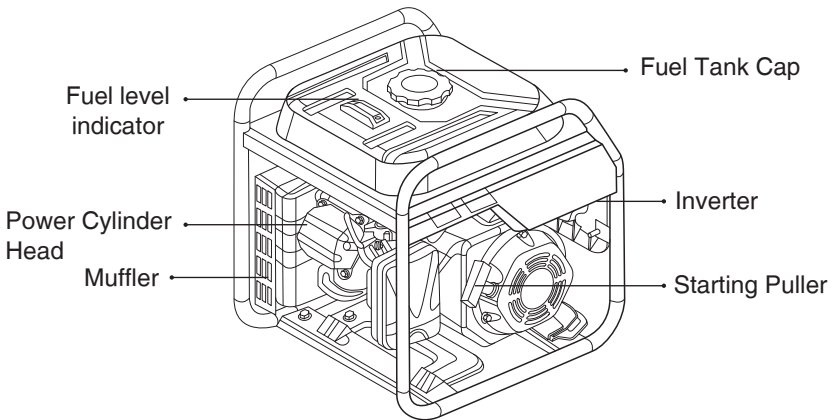
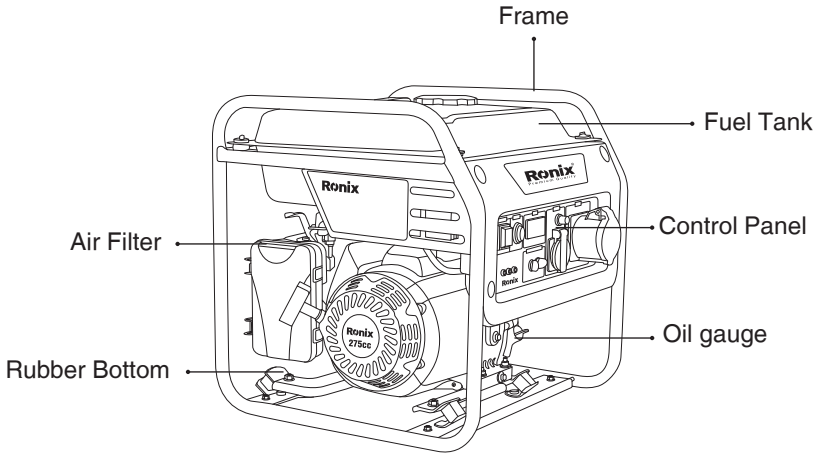

This operator's manual includes all relevant information, please read it carefully. operator's manual includes all relevant information, please read it carefully. This related information is primarily intended to help you avoid damage to the generator set, other property, and the environment. we have provided relevant operating procedures and information on some labels and this operator's manual. These messages alert you to notice potential hazards that could harm you and others.

YOU WILL FIND IMPORTANT SECURITY INFORMATION IN MANY FORMS, INCLUDING:

- 1- Safety label-pasted on the generator set.
- 2- The significance of these three warning words:

DANGEROUS:

If not follow these notices, it will be a risk of personal injury or death.

CAUTIOUS:

If not follow these notices, you will be injured.

IMPORTANT INFORMATION

The generator set is designed for use with appropriate power requirements of electrical equipment. Other applications will likely injure the user, and damage the generator set and other property.

If you follow the notice of this operator's manual and generator set, it can prevent many accidents, The most common potential hazards are described below, while providing the best way to protect you and others.

USER RESPONSIBILITY

Grasp how to stop the generator in case of an emergency.

- 1- Understand the purpose of all generator set controls, outlet sockets, and connectors.
- 2- Make sure proper instructions are given to any operator.
- 3- Don't allow the children to operate generator set.
- 4- The checking must be done before operating when we start the generator set to avoid personal injury and equipment damage.
- 5- Children and pets must be kept out of the operating area.
- 6- Prevent being scaled by generator set components or injured by operate the gasoline generator set on a stable surface.
- 7- The angle of inclination cannot exceed 20 degrees from the horizontal plane, otherwise it may cause fuel spillage.

- 8- The angle of inclination cannot exceed 20 degrees from the horizontal plane, otherwise it may cause fuel spillage.
- 9- Don't place anything on the generator set to prevent a fire disaster.

CARBON MONOXIDE POISONING HAZARD

The exhaust gas from the generator set contains poisonous colorless and odorless carbon monoxide gas. Inhalation of this fume may cause consciousness.

If you operate the generator set in an enclosed or semi-enclosed place, the air may contain a large number of toxic exhaust fumes. Don't run a generator set in a garage, indoors, or next to an open window or door. Important safety information is fully explained in this book - please read it carefully.

ELECTRIC SHOCK HAZARD

- 1- If used improperly, the power generated by the generator set can cause severe electric shock, or even death by electrocution.
- 2- In wet conditions, such as rainy days, snowy days, poolside, dripping water, or wet hands, using generator sets or electrical equipment may cause electrocution. Please keep the generator set in a dry state.
- 3- If the generator set is stored outdoors without any weather precautions, check the electrical components on the control panel before using. Moisture or ice can cause electrical components to malfunction or short out, which can cause electric shock.
- 4- Don't connect generators to building electrical systems unless a professional electrician has installed a protective switch in front of the building.

FIRE BURN HAZARD

- 1- High temperatures caused by the exhaust system are high enough to

ignite some materials.

2- Place the generator set at least 1 meter away from buildings, or other equipment during operation.

3- Don't seal the generator set.

4- Please keep flammable and explosive materials away from the generator set.

5- The muffler will be very hot during operation and remain hot for some time after shutdown. At this point, don't touch the muffler, and let the generator cool down before storing it indoors.

REFUELING NOTES

Gasoline is flammable and gasoline gas may cause an explosion, if the generator set has been running, please let it cool down first. Only stop the generator set and refuel outdoors with good ventilation. When refueling please don't overfill the tank. Don't smoke near gasoline and keep away from other flames, sparks, etc. Make sure to wipe up any spilled fuel before starting the generator.

■ENGINE SWITCH RECOIL

Engine switch, control ignition system.

OFF: stops the engine.

ON: running position, start by hand puller.

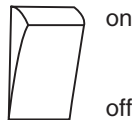

■DIGITAL DISPLAY

After the generator set starts successfully, it will display the output voltage, frequency, running time, and accumulated time.

■ INDICATOR LIGHT

GREEN: The running indicator light represents the normal operation of the equipment and the output voltage is Normal.

RED: overload indicator light.

■ BLINKING

It means that the load of the generator set is too large, exceeding the rated power, and it is recommended to reduce the load power.

YELLOW: engine oil indicator light, which means the amount of engine oil is low, please add engine oil in time, otherwise the generator set can't run normally.

PARALLEL INTERFACE

Two or more similar products can be used in parallel, and the efficiency of the parallel machine is $\geq 90\%$. The red jack corresponds to the red jack, and the blackjack corresponds to the blackjack. After the two machines are connected, start the first generator set, and start the second generator set until the green running indicator light is always on, until the second When the green running indicator light of the generator set is always on, the parallel operation is successful.

OUTPUT SOCKET

Generator set voltage output: pay attention to safety when plugging into the socket, and ensure that the load has no short circuit.

■ OIL ALARM SYSTEM

The oil warning system is used to prevent engine damage caused by insufficient oil in the crankcase. Before the amount of oil in the crankcase drops to the minimum safe value, the oil alarm system will automatically stop the engine (the engine switch is still in the "on" position).

If the engine stalls and will not restart, check the oil level before servicing other areas.

OVERLOAD PROTECTION

When the load is greater than 5.0kW, the red-light flashes.

The load is protected within 30 seconds to close the output, and the red light is always on.

■SHORT CIRCUIT PROTECTION

When the load is short-circuited, the product will be protected immediately, the output will be cutoff, the red light will always be on, and the power will be restored.

OVER TEMPERATURE PROTECTION

When the temperature of the inverter is higher than 80c, the red indicator light flashes for 15 seconds and then the product turn off the output, and the red light is always on.

■GROUND TERMINAL

The ground terminal is connected to the frame of the generator set, and it is also the ground terminal of each socket. Before using the grounding terminal, consult with local dealer.

■FUEL DISPLAY TABLE

The fuel display table is a device that measures the fuel level in the fuel tank.

A red indicator on the glass will show the oil level condition.

For an extended operating time, fill up with oil before running. Check the oil level by placing the generator set on a level surface. At the same time, please perform a refueling operation air the shutdown.

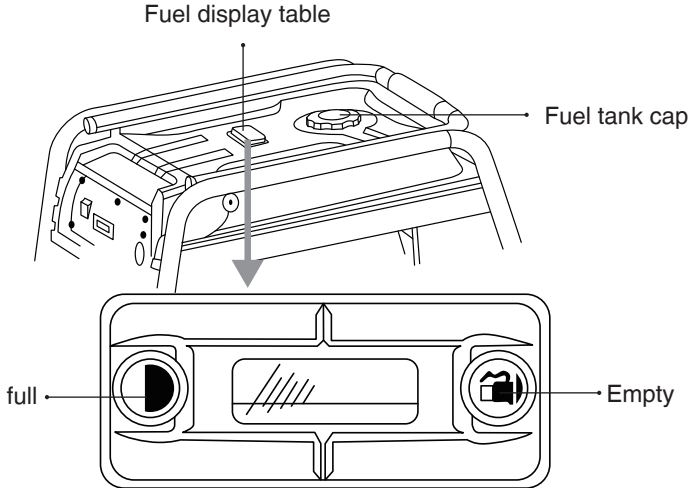

Read and understand this operator's manual. Master the functions and operating of the control panel.

When the generator set is used for power equipment, be careful not to exceed the load limit of the generator set.

IS THE GENERATOR READY?

For your safety and to maximize the life of your equipment, it is important to take some time to inspect the condition of your generator set before operating it. use generator set.

Make sure that any problems you find have been fixed, if not, please contact your dealer for inspection and repair.

Before the operation, if the generator set has not been properly maintained, there are problems with it and don't repair it well, it may cause serious injury to you.

To prevent fire, keep generators at least 1 meter away from building walls or other operating machines. Keep flammable objects away from the generator.

When performing pre-work inspections, make sure that the generator set is on a level surface and the generator switch is in the "OFF" position.

■ CHECKING THE ENGINE

Check the oil level. A low oil level will cause the oil warning system to stop the engine from running.

Check the air filter. A dirty air filter will block air from entering the carburetor, reducing engine and generator performance.

Check fuel level. Restarting the engine after the fuel tank is full, to help avoid or reduce the frequency of stoppages for refueling.

■ PRECAUTIONARY GUIDELINES FOR SAFE OPERATIONS

Before running the generator set for the first time, please read the relevant chapters of generator set safety instructions and preparations before operation. For your safety, avoid starting and running the generator set in a closed and airtight place operation. For your safety, avoid starting and running the generator set in a closed and airtight place such as a garage. The toxic carbon monoxide gas in the exhaust gas is easy to accumulate in a sealed environment and causes illness or death.

NOTICE:

Before connecting the AC unit or power cord to the generator: Use grounded three-point wiring, tools, and electrical equipment, or use double insulated tools and electrical equipment to ensure that the wiring harness can withstand the maximum current of the electrical equipment. Check whether the wiring harness and socket are exposed or damaged, if damaged, please replaced them to avoid the risk of electric shock.

Make sure that the amperage of the tools and equipment doesn't exceed the amperage of the generator set, be careful not to exceed the maximum output power of the generator set, and the operating time between threated value and the maximum value output power does not exceed 30 minutes. Operate the generator set at least 1 meter away from walls or other operating equipment.

Don't operate the generator set in a sealed environment.

START THE GENERATOR SET

To prevent fire effectively, please keep at least 1 meter away from walls or other equipment during operation. Don't place flammable and explosive items near the generator

When running the generator set, keep a distance of more than 1 meter from walls or obstacles that may damage or cause the generator set to overheat. Allow the generator set to cool in a space of at least 1 meter. Refer to "Precautionary Guidelines for Safe Operation" and confirm with "Is the generator ready?"

For how to connect the load to the generator set please refer to AC operation.

1- Leave the fuel valve in the "ON" position.

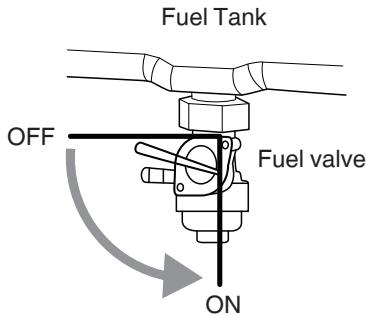

2- When starting the engine from a cold engine, pull the damper handle to the "CLOSE" position.

When restarting and warming up the engine, let the damper handle be in the "OPEN" position.

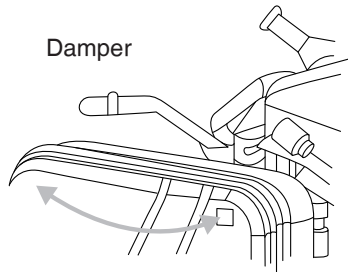

■ USE ELECTRIC START

position and keep it in that position until the engine start. If the engine fails to start within 5 seconds, release the switch, wait for more than 10 seconds, and then start the second time.

! NOTICE:

The generator set shouldn't start for more than 5 seconds each time, otherwise, the electric starter motor may overheat, or even damage the starter motor. When not in use, please press the engine switch to the "off" position.

Don't press the "on" position, causing the battery to drain.

■ USE RECOIL STARTER

A. Press the engine switch to the "on" position.

B. Gently pull up the starter handle until you feel resistance, then gently put it back, and pull it hard again.

After the start is successful, reconfirm that the generator set and its circuit equipment are correct, connect the load, and then open the circuit breaker.

Don't let the starter handle spring back suddenly after starting, but put the handle back gently to protect the starter from damage.

! NOTICE:

Don't let the starter rope rub against the engine, or the rope will wear and tear.

3- If the throttle handle is in the "OFF" position when the engine is started after the engine warms up, slowly put the throttle handle in the "Open" position.

- 1- Press the air switch to the "off" position.
- 2- Press the unit switch to the "off" position.
- 3- Turn the fuel valve to the "off" position.

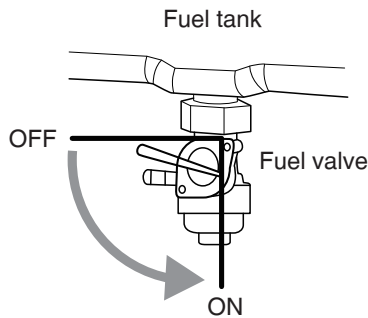
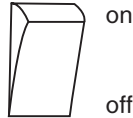

EMERGENCY HANDLING

When an emergency happens and you don't know how to deal with it, you can press the unit switch button to the "OFF" position directly, to stop the generator set.

■ AC OPERATION

- 1- Start the generator set.
- 2- Connect the electrical equipment, the power required by most motor device exceeds the rated the rated value when starting.
- 3- Connect the air switch to the "on" position

When the operation of electrical equipment becomes abnormal, such as

a slow response or sudden stop, please stop immediately. Remove the connection between the electrical equipment and the generator set, and check whether it is a problem with the electrical equipment or because it exceeds the rated output of the generator set. Large overloads will damage the generator set. Slight overloading also has the potential to reduce the life of the generator set.

BACKUP POWER

■CONNECT TO BUILDING ELECTRICAL SYSTEM

The generator set can be used as the power supply equipment for the building's electrical system. If the generator set is selected as the backup power supply of the industrial company, when connecting the generator set; an isolation switch must be installed to separate it from the building circuit. The installation must be carried out by a senior. Some local laws require generator sets to be registered with the utility company, check local regulations for proper registration and operation.

GROUNDING SYSTEM

The generator set has a grounding system that enables the frame assembly of the generator set to be connected to the ground terminal of the AC output socket. The grounding system isn't connected to the AC center line. If a socket circuit tester is used to test the generator set, the displayed ground circuit condition will be different from that of the household socket.

SPECIAL REQUIREMENTS

There may be some legal or local codes, ordinances, etc. Regarding the use of generator sets. Please consult senior electricians, electrical inspectors, or relevant institutions familiar with the relevant authority.

THE IMPORTANCE OF MAINTENANCE

Good maintenance is a prerequisite for safe, economical, trouble-free operation and is also good to reduce pollution.

To help you properly maintain the generator set, the following content will contain the maintenance schedule, daily, monitoring procedures, and simple maintenance procedures using basic tools, other more difficult maintenance jobs that require the use of special tools are best performed by professionals or technicians and other experienced mechanics. The contents of the maintenance schedule apply only under normal operating conditions. If you operate the generator under special conditions; such as long-term high load or high-temperature operation or use in dusty areas, please consult the dealer for relevant opinions and suggestions suitable for your special situation.

Remember that the dealer knows the performance of the generator set very well and has the complete equipment to maintain and repair it.

To make sure the best quality and reliability, use new genuine RONIX parts or their equivalent for repair and replacement work.

MAINTENANCE SAFETY

Please follow the important safety precautions. Of course, we can't remind you of every potential danger in the maintenance process. You still need your judgment to decide whether to carry out.

NOTICE:

Failure to properly follow maintenance instructions and precautions could result in personal injury or death. Always follow the maintenance procedures and precautions listed in this instruction manual.

SAFETY PRECAUTION

Make sure the engine is shut down before starting any maintenance or

repair. This will help eliminate some potential dangers.

Carbon monoxide poisoning of engine exhaust. When operating the engine group at any time, make sure that the ventilation state is well.

Burning parts cause burns let the engine and exhaust system be allowed before contact.

Damage caused by operating parts. Read the relevant instructions before starting to ensure that you have the tool and techniques you need.

To reduce the possibility of fire or explosion, please be careful when working with gasoline. Use non-combustible solutions to replace gasoline cleaning parts. Follow the fuel-related components away from the cigarette butt, spark, etc.

MAINTENANCE SCHEDULE

| Daily Maintenance Period | | Use every time | The first month or 20 hours | Every 3 months or 50 hours | Every 6 months or 100 hours | Every year or 300 hours |
|---|-----------|----------------|-----------------------------|----------------------------|-----------------------------|-------------------------|
| According to the instruction month that arrives first or Maintenance of running hours | | | | | | |
| Engine oil | Check oil | x | | | | |
| | Replace | | x | | x | |
| Air filter | Clean | x | | | | |
| | Replace | | | 0(1) | | |
| Sedimentation cup | Clean | | | | x | |

| | | | | | | | |
|----------------------|-----------------|---|--|--|--|---|---|
| Spark plug | Check to adjust | | | | | x | |
| | Replace | | | | | | x |
| Valve gap | Check to adjust | | | | | | x |
| Burning room | Clean | | Every 500 hours | | | | |
| Fuel tank and filter | Clean | | | | | | x |
| Fuel tank pipe | Check | x | Every 2 years (if necessary, please replace) | | | | x |

Use in dusty areas, the maintenance frequency should be increased. These tasks should be carried out by dealers unless you have suitable tools and good technology. Please refer to the wing tiger maintenance manual for maintenance work.

When used for commercial purposes, record the number of hours of operation, to determine the time interval for maintenance.

ADD FUEL

After the engine group is shutdown, check the fuel display table. If the oil level in the fuel tank is too low, please add fuel.

NOTICE:

Gasoline is highly flammable and explosive. You may be burned or severely damaged when dealing with fuel. Turn off the engine and stay away from high temperatures, sparks, and flames. You can only deal with fuel outdoors. Wipe off the overflowing fuel in time.

Fuel will corrode paint and plastic products. When you add fuel, please be careful not to spill oil. The damage caused by fuel leakage is not guaranteed. Infuse fuel in a well-ventilated area before start-up. If the engine just stops, let it cool first. Try not to let the fuel overflow when

refueling. The amount of refueling shouldn't exceed the fuel filter's upper limit oil level. Tighten the fuel tank cover after refueling. Don't refuel the generator indoors, gasoline and gas may be exposed to flames and sparks causing a fire. Keep it away from the electrical indicator, barbecue rack, electrical appliance, electric tool, etc.

The overflowing fuel is not only a hidden fire hazard but also affects the environment. Please immediately dry the overflowing fuel.

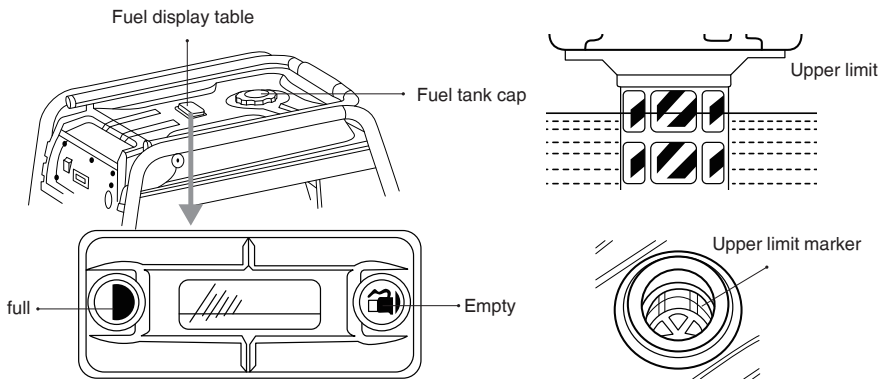

Tighten the fuel tank cap after adding oil Fuel recommendation.

ENGINE OIL LEVEL INSPECTION

After the shutdown, check the oil level at the horizontal position.

- 1- Take out the oil level measurement ruler and wipe it clean.
- 2- After inserting completely, take it out to detect the oil level.
- 3- If the measured oil level is close to or lower than the oil level measurement of the oil level measuring ruler. Sprinkle the oil plug ruler, and add the recommended oil to the label of the label.
- 4- Reinststate machine oil level measuring ruler.

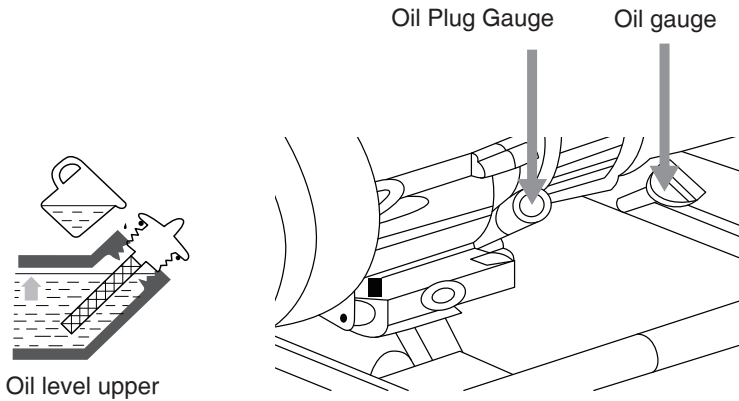

When the oil level is lower than the minimum safety limit, the oil alarm system will automatically stop the engine. To avoid the inconvenience caused by accidents, please check the oil level regularly.

ELECTRIC ENGINE OIL REPLACEMENT

When the machine is heating, the oil is leaked by the oil to ensure fast, and it is completely exhausted to exhaust the oil.

- 1- Place the generator set on the wooden rack to ensure that there is space to place containers, and remove the oil plug ruler, oil leakage bolt, and sealing ring.
- 2- Rest the oil, then tighten the oil bolt again, put it on the new sealing ring, and tighten.

NOTICE:

Pay attention to protecting the surrounding environment. We recommend that you put it in a sealed container and send it to the waste processing field. Don't throw the used oil in the garbage or fall on the ground, and pour it into the sewer.

- 3- Inject the recommended oil into the upper limit of the schedule of the oil -stuffed ruler.
- 4- Tighten the oil plug ruler.

After processing the used oil that has been used, wash your hands with soap and water.

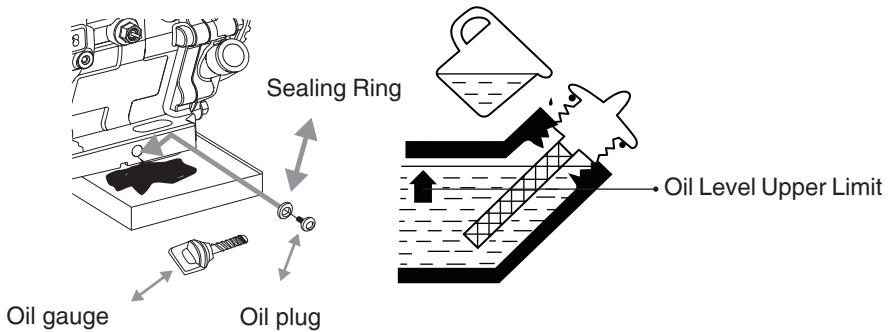

ELECTRIC ENGINE OIL RECOMMENDATION

The oil is a major factor affecting the performance and service life of the engine.

Please use 4 rushing gasoline engine oils that meet or exceed the API classification of SE or a considerable level. Please pay attention to checking the API classification label on the oil packaging to ensure that it has an SE or a very grade letter. It is recommended to use SAE10W-30 engine oil. When the local average temperature is within the recommended range, you can use other viscosity oil in the table.

AIR FILTER MAINTENANCE

- 1- Remove the air filter.
- 2- Separate the buckle on the upper part of the filter cover, remove the air filter cover, and be careful not to damage the air filter cover.
- 3- Remove the filter element from the air filter box.
- 4- Check whether the air filter element is clean and in good condition. If the air filter element is dirty, clean it, if the air filter element is damaged, replace it.
- 5- Reinstall the air filter element into the air filter.

6- Reinstall the air filter cover and install the air filter bolts. Confirm that the air filter bolts are tightened so that there is no gap between the upper cover and the lower cover.

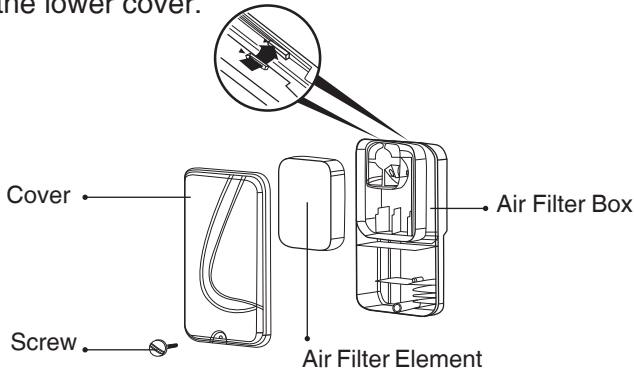

⚠ NOTICE:

Running the generator set without the air filter element or the air filter element is damaged, dust will enter the engine, causing rapid wear and tear on the engine.

CLEANING OF THE AIR FILTER ELEMENT

Dirty air filter elements can block air from entering the carburetor, reducing engine performance. If the generator set is used in a dusty area, the air filter element should be cleaned more frequently than specified in the maintenance schedule.

1- Clean the filter element with warm soapy water, rinse and dry, or wash the filter element with a non-flammable solution and dry it.

2- Dip the filter element into the clean engine oil, and squeeze out excess oil. If too much oil is left in the filter element, the engine will smoke when started.

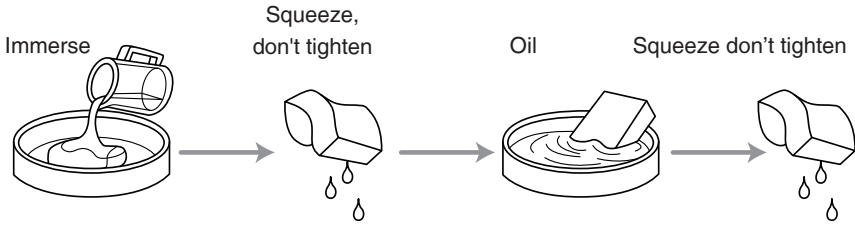

3- Wipe off the dust on the air filter seat and air filter cover with a damp cloth, and be careful not to let the dust enter the air pipe leading to the carburetor.

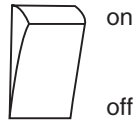

■ FUEL FILTER CLEANING

1- Equipped with electric start type:

Turn the fuel valve to the OFF position, then remove the settling cup and O-ring, discarding the O-ring.

2- Install the settling cup in anon-flammable solvent and dry it completely.

3- Install the settling cup and new O-ring and fasten the settling cup.

4- Turn the fuel valve to the ON position, and make sure there is no fuel leakage.

⚠ NOTICE:

Gasoline is highly flammable and explosive. You could be burned or seriously injured while handling fuel.

Shut off the engine and keep away from heat, sparks and flames. Fuel should only be handled outdoors.

Wipe up spilled fuel promptly

SPARK PLUG MAINTENANCE

Spark plug recommendation: F7TC

To ensure the normal operation of the generator set, the spark plug gap must be adjusted correctly and carbon deposits removed.

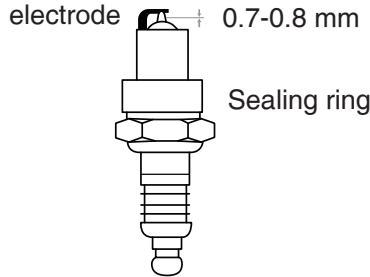

⚠ NOTICE:

Incorrect spark plugs can cause engine damage.

If the engine is hot, maintain the spark plugs after it cools down.

- 1- Remove the spark plug cap and clean the dirt around the spark plug.
- 2- Use a spark plug wrench to remove the spark plug.

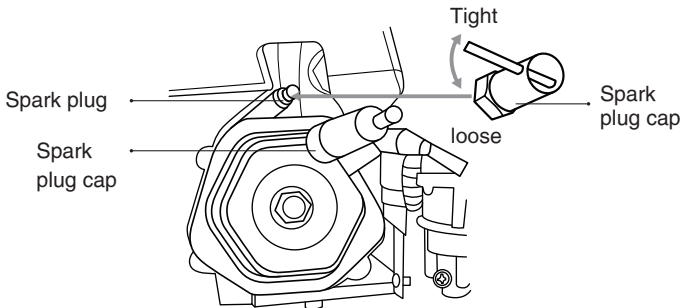

3- Check spark plugs. Replace the spark plug if the electrode is worn or the ceramic is cracked, broken, or corroded.

4- Measuring the sparkplug electrode gap with a fee.

If necessary, the side of the electrode can be bent to adjust the gap.

Spark Plug gap: 0.7-0.8mm

5- Make sure the spark plug seals are in good condition.

To prevent the threads from slipping, carefully reinstall the spark plug by hand.

6- After reinstalling the spark plug, tighten it with the spark plug sleeve.

If it is a used spark plug, tighten 1/8 -1/4 turn after the spark plug is tight. If it is a new spark plug, give it another 1/2 turn after the spark plug is tight.

 **NOTICE:**

If the spark plug is not tightened tightly, it will cause the engine to overheat and damage. If the spark plug is over-tightened, it will damage the thread of the cylinder head.

7- Install the spark plug cap.

■ BATTERY MAINTENANCE ONLY FOR AN ELECTRIC START

When the engine is running, the power charging system of the generator set will charge the battery. However, if the generator set is only used periodically, the battery should be charged at least once a month to maintain battery life.

 **CAUTION:**

Highly corrosive and toxic sulfuric acid (electrolyte) in batteries.

Eyes or skin contact with electrolyte will cause severe burns.

When working near the battery, please wear protective clothing and eye protection. Keep batteries away from children.

■ EMERGENCY METHODS:

Eye-Flush with water from a cup or other container for at least 15 minutes (water under pressure can damage eyes), then seek immediate medical attention.

Skin-Remove clothing, flush skin with plenty of water, and seek medical attention immediately.

Internal-Drink plenty of water or milk, then seek medical attention right away.

STORAGE PREPARATION

Proper storage preparation is important to keep the generator set in trouble-free and good-looking condition. The following steps will help prevent rust and corrosion damage to the function and appearance of the generator set and allow easy starting of the generator set when it is returned to service.

■ CLEANING

Wipe the generator set with a damp cloth. After the generator set is dry, touch up the damaged paint and apply a thin film of oil to any areas that may have rusted.

NOTICE:

■ FUEL

Gasoline will deteriorate and oxidize to varying degrees depending on the region in which you use your generator set. Even in as little as 30 days, gasoline can deteriorate and oxidize and cause damage to the carburetor or fuel system. Please consult the RONIX power dealer for the local storage method.

Gasoline oxidizes and deteriorates in storage, and old gasoline can cause starting difficulties and leave gum deposits that clog the fuel system. If the gasoline in your generator set has deteriorated in storage, you may need to have your carburetor and fuel system components repaired and replaced.

The amount of time gasoline can remain in the fuel tank and carburetor without causing performance issues will vary based on factors, such as gasoline blend, storage temperature, and whether the fuel tank is filled. Air in a partially filled fuel tank can accelerate fuel deterioration.

Also, high storage temperatures will accelerate fuel deterioration. Fuel can deteriorate in a matter of months if not enough gasoline is filled into the fuel tank. Drain the gasoline from the fuel tank and carburetor.

! NOTICE:

Gasoline is highly flammable and explosive.

You could be burned or seriously injured while handling fuel.

Fuel should only be handled outdoors.

Wipe up spilled fuel promptly.

1- Check whether the fuel valve is closed.

2- Place a suitable gasoline container under the carburetor and use a funnel to prevent gasoline from spilling.

3- Loosen the oil drain screw of the carburetor and drain the gasoline in the car carburetor.

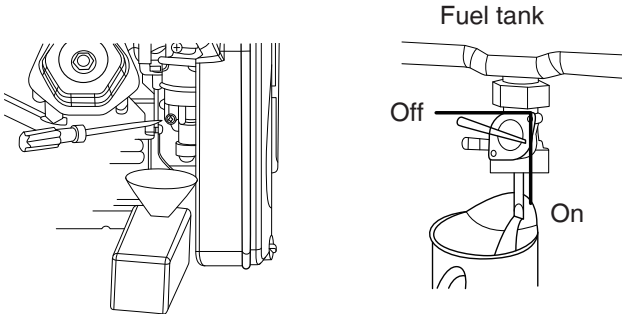

4- After draining the petrol into the container, tighten the drain screw.

5- Place a suitable gasoline container under the settling cup and use a funnel to prevent gasoline from spilling.

6- Remove the sediment cup and turn the fuel valve handle to the ON position.

7- Drain the gasoline completely, and then put the sedimentation cup back.

ENGINE OIL

1- Replace the engine oil

2- Remove the spark plug.

3- Add a tablespoon of clean motor oil to the cylinder.

4- Pull the starter rope several times to evenly distribute the oil in the cylinder.

5- Reinstall the spark plug.

6- Gently pull up the starter handle until resistance is felt. At this point, the piston is in the compression stroke and both the intake and exhaust valves are closed. Storing the engine in this state can help prevent internal corrosion. Then gently release the starter handle.

PRECAUTIONS FOR STORAGE

If your generator was stored with gasoline in the fuel tank and carburetor, be careful to avoid the risk of ignition of gasoline vapors. Choose equipment that is well-ventilated and away from fire-related equipment. Store generator sets in places where furnaces, water heaters, or clothes dryers work, and avoid places where spark-point motors or power tools are operated.

If possible, avoid damp storage areas, because damp conditions are prone to rust and corrosion.

Unless all the fuel in the fuel tank is drained, be sure to set the fuel valve to "off" to reduce the possibility of fuel leakage. Place the generator set on a level surface. Sloped surfaces can cause fuel or oil spills.

After the engine and exhaust system have cooled down, cover the generator set to keep out dust. If the engine and exhaust system are hot, some materials may ignite or melt.

Don't use plastic sheeting as a dust cover. Non-porous covers allow moisture around the generator set, which promotes rust and corrosion.

REMOVE USE

Inspect the generator as described in the "Before Operation" chapter of this manual.

If fuel was drained during storage, fill the tank with new gasoline. If you have stored spare gasoline in a container, make sure that the gasoline is not spoiled. Gasoline will be oxidized and spoiled for a long time, which will cause difficulty in starting.

If the cylinder was stored with oil on it, the engine may smoke slightly when restarted, this is normal. If the generator set has been run before transport, allow the generator to cool for at least 15 minutes before loading the generator set on the transport vehicle. If the engine and exhaust system are hot, people may be burned or certain fuels may be ignited.

Keep the generator set in a horizontal state during transportation to reduce the possibility of fuel leakage, and put the fuel valve in the OFF position.

When bundling the generator set with ropes or tie straps during transportation, be careful to use only frame iron rods as the binding point. Do not tie cords or straps to any part of the generator body.

TROUBLE SHOOTING

1- THE ENGINE DOESN'T START

| Possible Reason | Correct |
|--|---|
| The fuel valve handle is in the OFF position | Rotate the fuel valve handle to the ON position |
| The choke is in the OPEN state | Unless the engine is hot. Otherwise put the damper handle in the CLOSED state |
| The engine switch is in the OFF position | Engine switch to ON position |
| Run out of fuel | Add fuel |

| | |
|--|---|
| Fuel deterioration: The fuel was not treated or the generator set was stored Gasoline drained or refueled with spoiled gasoline | Drain the fuel from the fuel tank and carburetor refill with new fuel |
| The oil level is too low, causing the oil alarm to operate to stop the engine | Turn the engine switch to the OFF position to restart the generator |
| Faulty, clogged, or improperly spaced spark plugs | Adjust the gap or replace the spark plug |
| Wet spark plugs with fuel (flooded engine) | Dry the spark plugs and reinstall them |
| Fuel filter failure; carburetor failure; ignition failure; fuel valve blockage, etc. | Take the generator set to the RONIX Power dealer or refer to the service manual |

2- UNDERPOWERED ENGINE

| Possible Reason | Correct |
|----------------------------|---------------------------------|
| Air filter element clogged | Clean or replace the air filter |

| | |
|--|--|
| Fuel deterioration: The fuel was not treated or refueled when the generator set was stored. Spoiled gasoline was added to the oil | Drain the fuel from the fuel tank and carburetor refill with new fuel |
| Fuel filter failure; carburetor failure; ignition failure; fuel valve blockage, etc. | Take the generator set to a RONIX Power dealer or refer to the service manual. |

3- VOLTAGE LINE SOCKET

| Possible Reason | Correct |
|---|---|
| The circuit breaker is still in the OFF position after starting | Turn on the air switch to the ON position |
| The circuit breaker is still in the OFF position after starting | Disconnect running equipment and temporarily stop the engine. Make sure to disconnect all equipment and close the circuit breaker before starting, and then restart the generator set. If there is still a short circuit in the generator set, send the generator set to the Escape Power dealer. |
| Generator failure | Replace or repair faulty components as appropriate |
| Overload protection | Restart gen set |
| Short circuit protection | Check whether the load is short-circuited, and restart the generator set after confirming that the load is normal. |



www.ronixtools.com