

Ronix[®]

Premium Quality

12L HIGH PRESSURE AIR GREASE INJECTOR RH-4307

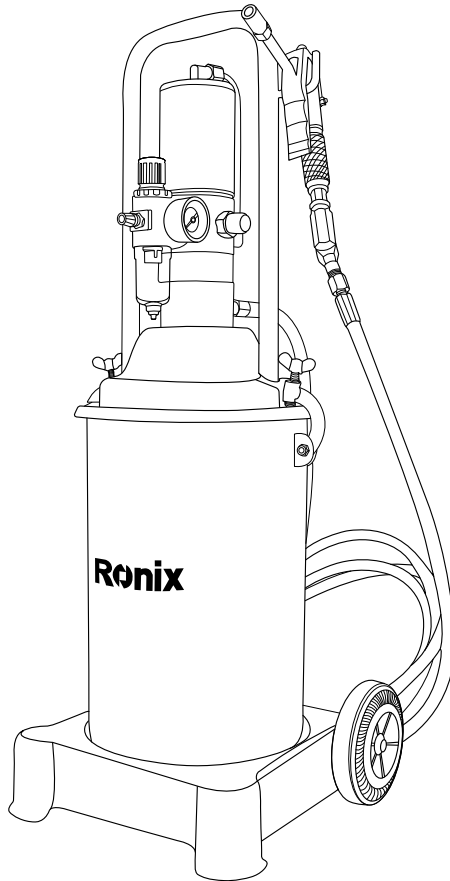

TECHNICAL SPECIFICATIONS

Model	RH-4307
Total Height	805mm
Stand Dimension	330×φ220
Body Diameter	220mm
Capacity	12Lit
Max Pressure	400 Bar 5700 PSI
Working Pressure	6-8Bar 87-116PSI
Pressure Gauge Graduation Unit	0-1MPA 0-150PSI
High Pressure Rubber Hose Length	4m
Body Material	Steel
Weight (Gross/Net)	11.25Kg / 9.25Kg
Included	1PC HYQ 200with Plain Type Nozzle; 1PC High pressure rubber hose:4×6×14.5mm 1PC-30cm gun hose 1PC-pointed type nozzle 1set-repair kit

PART LIST

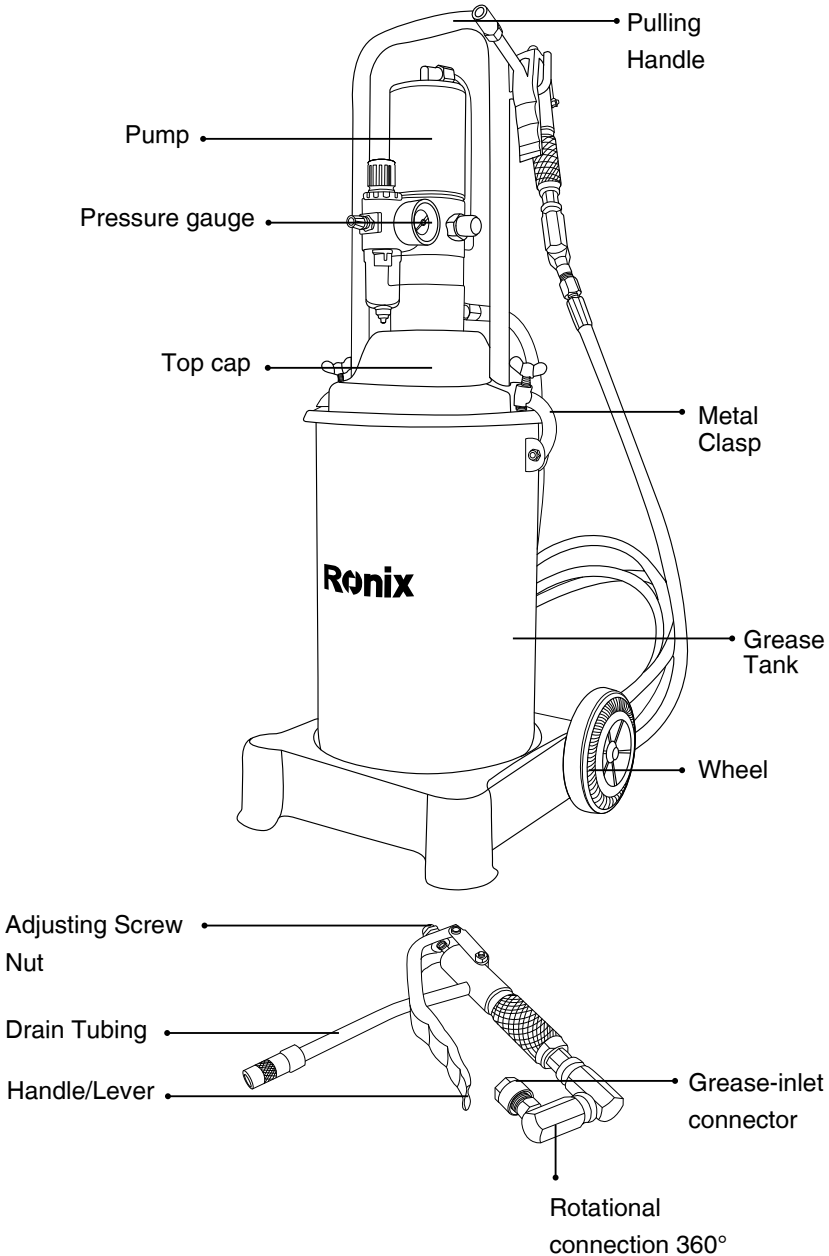

GENERAL SAFETY WARNINGS

WARNING!

- Read all safety warnings and all instructions. Failure to follow the warnings and instructions may result in electric shock, fire and or serious injury.
- Save all warnings and instructions for future reference.

■ WORK AREA SAFETY

- Keep work area clean and well lit. Cluttered or dark areas invite accidents.
- Don't operate device in explosive atmospheres, such as in the presence of flammable liquids, gases or dust. Because which may ignite the dust or fumes.
- Keep children and bystanders away while operating. Distractions can cause you to lose control.

■ PERSONAL SAFETY

- Stay alert, watch what you are doing and use common sense when operating. Don't use while you are tired or under the influence of drugs, alcohol or medication. A moment of inattention while operating may result in serious personal injury.
- Use personal protective equipment. Always wear eye protection. Protective equipment such as dust mask, non-skid safety shoes, hard hat, or hearing protection used for appropriate conditions will reduce personal injuries.
- Prevent unintentional starting. Ensure the switch is in the off position before connecting to power source and/or battery pack, picking up or carrying the tool. Carrying with your finger on the switch or energizing that have the switch on invites accidents.
- Remove any adjusting key or wrench before turning the on. A wrench or a key left attached to a rotating part may result in personal injury.
- Don't overreach. Keep proper footing and balance at all times. This enables better control in unexpected situations.
- Dress properly. Don't wear loose clothing or jewelry. Keep your hair,

clothing, and gloves away from moving parts. Loose cloths, jewelry or long hair can be caught in moving parts.

 **WARNING!**

- Do not make any modifications to the device and only use it for its intended purpose. Improper use or modification might lead to property damage and personal injury.

 **Caution!**

Danger of slipping due to lubricants. Immediately remove spilled or leaked lubricant and dispose of it properly.

Lubrication material are toxic and leaking lubricant can cause environmental damages!

■ DEVICE USE AND CARE

Ronix high-pressure grease injector uses compressed air as drive, the pump creates the high-pressure by pressing the grease, and the oil injected by the high pressure.

The grease injector is becoming an essential equipment due to the need for lubrication industrialization.

Its features are good reliability, low air consumption, high working pressure, convenient usage, high efficiency of production, capability of injecting grease of high viscosity. Applying in automobile, tractors, and other dynamic machines' grease injection aspects.

This machine can be used all year round Normal in .

- In winter use grease grade 0 and 1 lithium grease.
- In spring use grease grade 2 lithium grease.
- In summer use grease grade 2 and 3 lithium grease.

In order to avoid oil viscosity too hard, you can add a little engine oil and mix thoroughly.

 **Caution:**

- Recommended temperature range: between -20 and 120 Celsius .

- Recommended humidity range: between 20% and 80%.

The lithium grease used is made of higher fatty acid lithium soap thickening medium viscosity mineral oil added antioxidant and anti-rusting agents. It has good performance in water resistance, mechanical stability, oxidation stability and rust protection.

NLGI Grade	NLGI Grade	 <p>Fluid</p> <p>Very Hard</p>
000	445-475	
00	400-430	
0	355-385	
1	310-340	
2	265-295	
3	220-250	
4	175-205	
5	130-160	
6	85-115	

Machine noise at work is around 90Db.

APPLICATIONS

- grease inject called pressure ratio

The grease injector pump is combined with an upper air pump and lower plunger piston pump for compressing grease.

Air pump is the driving pump of plunger piston pump; compressed air is used to drive the plunger piston pump in reciprocating motion for grease inlet grease outlet and creating the grease pressure. Because the valid area of the piston of the cylinder is bigger than that of the cylinder of plunger piston pump, so pressure can be greatly enhanced, the valid area ratio is 50:1(it is called pressure ratio).

When 0.6Mpa compressed air is inputted, the output grease pressure can reach 30 Mpa.

■ Operation theory

The driving force of plunger piston pump is coming from the air pump, connected with the connecting pole, and have reciprocating motion with the air pump synchronously, in the motion, grease is inhaled and output high pressure.

■ Replace working position

When grease pump replace working position through horizontal short distance, it would depend upon the two wheels to carry on the migration; When grease pump replace working position through long distance, first the grease should be poured out of the container. The grease should transport alone.

■ Transportation

Before transportation, the grease must be removed from grease pump should be bonded in order to prevent the movement bringing the danger or damage.

■ Storage

Before storage, firstly you should recycle the grease in the container, then wash the container, clean the Pump body and pipelines with cleaning oil. After cleaning, you should make it dry then it will get a long service life Storage condition The clean grease pump should be put on the dry, ventilated condition to, it should be avoid high temperature, solarization or inflammable gas .

■ Troubleshoot

Problem	Possible cause	Solution
1- Improper lubricant delivery	a) Loose charging bar	Re-fasten charging bar.
	b) Dirty grease inlet	Find and remove dirt.
	c) Lubricating grease too thick	Change lithium grease depending on season: 1–2 times in winter, 2 times in spring and autumn, and 2–3 times in summer.
	d) Dirty valve	Remove dirt.
	e) Not enough grease in cone tainer	Top up with grease.
2- Pressure loss	a) Worn valve seals	Renew seals.
	b) Loose slide shoe or screws	Find and fasten loose parts.
3- Insufficient grease delivery pressure	a) Parts of outlet hose blocked	Find and clean blocked areas.
	b) Partial blockage of grease channel inside fat syringe	Find and clean blocked areas.
	c) Soiling of two one way valves	Remove piston and clean grease syringe.
4- Grease leak when air is deflated	Leaking V-type seal	Renew seal, clean contaminated area.
5- Grease leakage from rotating part of grease syringe	Leaky butyl rubber seal	Renew seal, clean contaminated area.

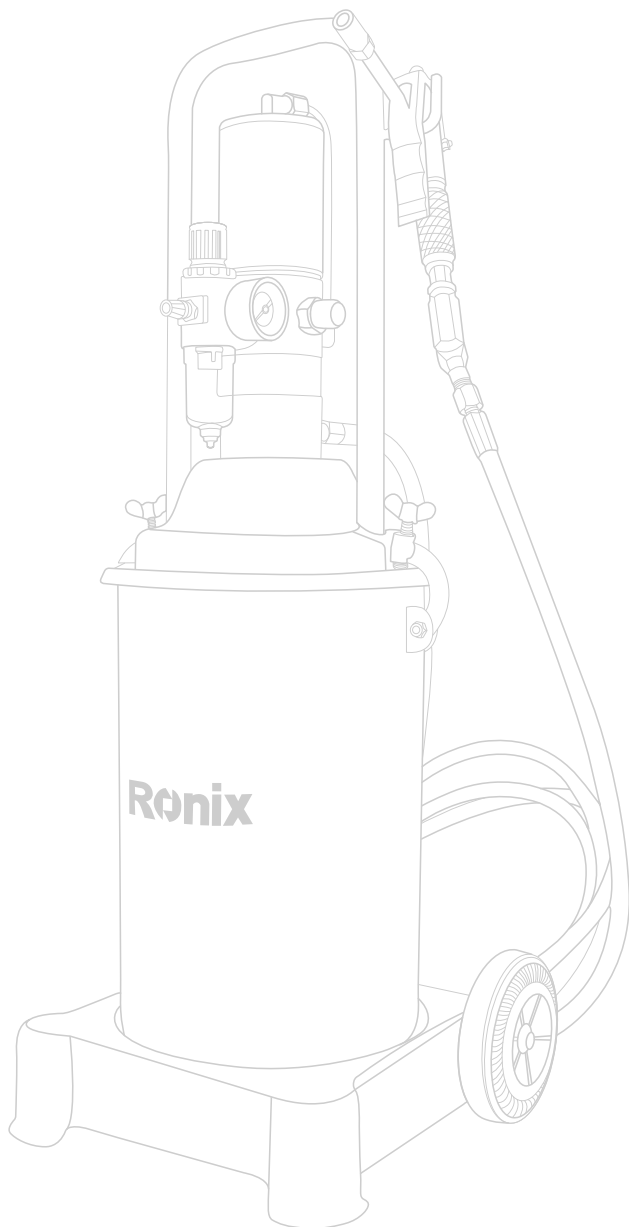

12L HIGH PRESSURE AIR GREASE INJECTOR



www.ronixtools.com