

Ronix[®]

Premium Quality

18 GAUGE 55MM BRAD NAILER RA-1850

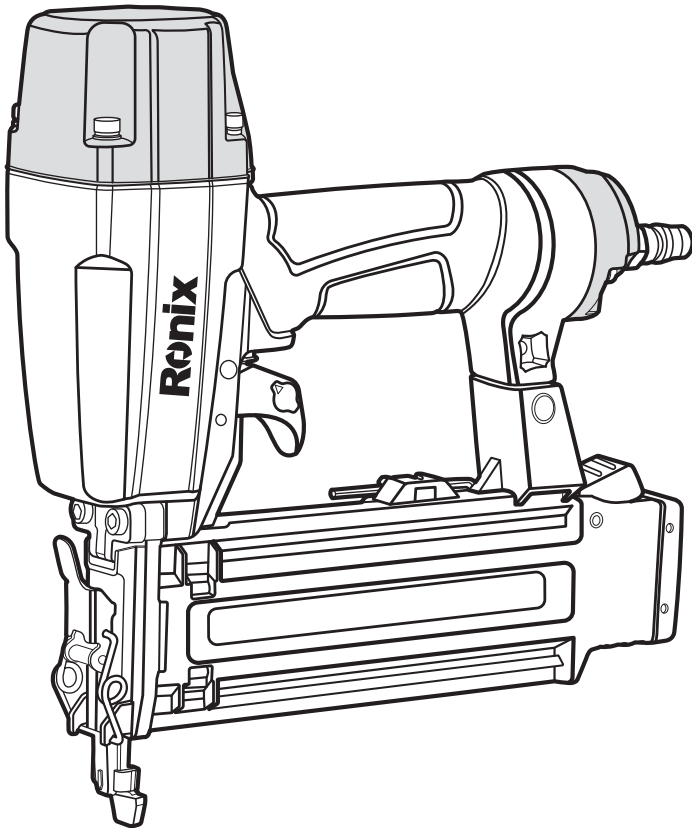

SPECIFICATIONS OF NAILER

Model	RA-1850
size	253mm×255mm×65mm
Weight	1.3Kg
Nail head	2mm
Max Pressure	120 PSI
nail features	1.26×1.05mm
nailing capacity	100 pcs
Required Pressure	60-100 PSI
Supplied In	Ronix color box
Includes	belt hook, Hex wrench , coil hose, Ronix coupler (5m), oil bottle

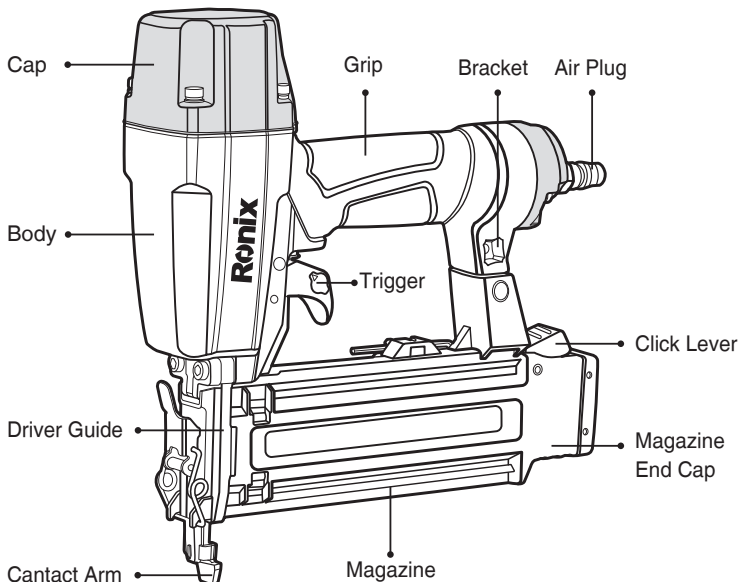

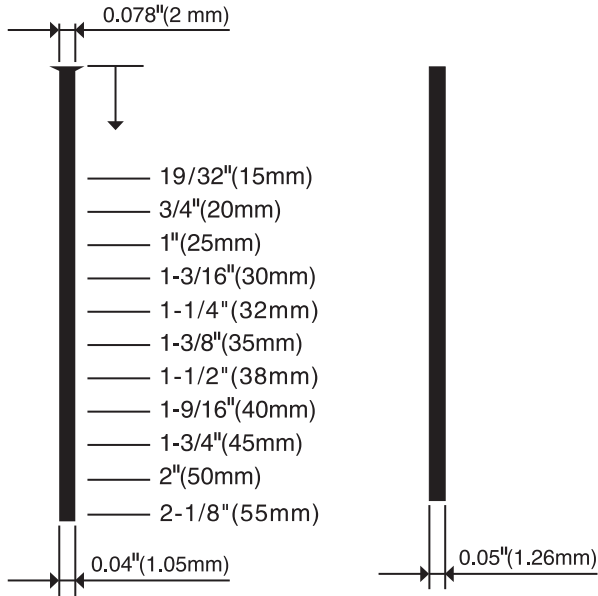

■ NAME OF PARTS

FASTENER SPECIFICATIONS SAFETY INSTRUCTIONS

⚠ DANGER!

1) Be sure to put goggles on before operation

Since a fastener fired wrongly through careless handling can spring out or you are always exposed to danger that can be caused by dust and extraneous substances dispersed by exhausted air, you must always wear goggles for operation. Goggles should meet requirements of ANSI Z89.1-1997 and be able to protect both the front and the sides. An employer has responsibility for having workers and all the other persons wear protective equipment in a workshop.

2) Put on hearing protective equipment in certain working environment.

In working environment exposed to loudness which may result in hearing loss, an employer (management) must provide hearing protection equipment to a user and others in the workshop and a worker must wear it if necessary.

3) Never use any power source but compressed air.

As this tool is designed and manufactured to operate using air pressure that is generated by an air compressor authorized by a safety certification authority, you cannot use any kind of gas combustible gases such as oxygen and acetylene except this. Otherwise, it may not only cause mechanical trouble but also malfunction or explosion, resulting in infliction of fatal injury on a user or those around him or her.

4) Use it within the optimum range of air pressure.

This tool is designed to operate within a range of pressure between 58 psi and 100 psi (or between 4 bar and 7 bar). Connect this tool to a pressure controllable device so that you can work under fixed pressure. When operating this tool, never use it under pressure of 120psi (8bar) and over. this tool can not connected to pressure higher than 120 psi (or 8 bar) , or wil damaged the parts.

5) Don't use it near inflammables (combustibles).

Never operate this tool near inflammables (such as thinner and gasoline). Combustible gas from such materials can be sucked into a compressor and compressed together with air, possibly resulting in explosion.

6) Be careful not to aim or fire it toward yourself or any other person in any case.

You should be careful not to aim it toward yourself or any other person in any case whether the tool is loaded with fasteners or not. Then, even if malfunction or undesired firing occurs, you can minimize damage caused by the fired fasteners. Otherwise, it may result in serious injury.

7) Never touch the trigger except when this tool operates for work.

Never touch the trigger except when air is connected to this tool, which operates for work. It is especially very dangerous to change the position or move around during operation with your finger fixed

on the trigger, and you may not do any similar action. Otherwise possible carelessness may result in infliction of serious injury on a user or those around him or her.

⚠ WARNING!

8) Connect a proper connector to this tool correctly.

The connector for this tool should never have pressure kept when air supply is cut off. If an improper part is applied, then the tool can operate due to pressure left within it even after the airline is disconnected possibly resulting in injury.

9) Disconnect the air line and empty the fasteners out of the container in case that the tool is not used.

Be sure to cut off air supply and empty the fastener container when the work is completed or when you move to another workshop, maintain, disassemble, or repair this tool, or clear jam. Make sure that the airline is disconnected in loading the container with fasteners again.

⚠ CAUTION:

10) Make sure that each fastener is locked tightly.

The tool can be damaged if you use it with each fastener loosened, or screws or bolts assembled wrongly. Make sure that all screws and bolts are assembled correctly and tightly before using the tool.

11) Never let a worker remove or manipulate a safety device, or recompose the tool at his or her discretion.

If you remove a safety device, or manipulate or recompose the tool at will, it can cause a drop in performance and breakdown of the tool and result in injury due to mechanical trouble and malfunction.

12) Be sure to disconnect the air line and empty fasteners out of the container if the tool is not used.

You must disconnect the air line and empty the fastener container when the work is completed or suspended, when you go out of a workshop, when you move or transfer the tool, or on other occasions.

13) Stick the muzzle correctly to the target plane for drive a fastener.

If correct drive a fastener is not implemented on the target plane, the

fired fastener can spring out, possibly resulting in injury.

14) You are prohibited from using the tool for other purposes than drive a fastener and from throwing or dropping it.

The resultant shock can cause damage to main parts or malfunction, possibly resulting in injury.

15) Never drive a fastener on hard or thin objects, an edge of the target surface or a fastener crown already driven.

Otherwise, the fastener fails to be driven in but springs out, thus inflicting an injury on a worker or those around him or her.

16) Conduct operations in an upright and safe position all the time.

Long-time work in an unstable and wrong position may put excessive stress on the body, possibly resulting in an injury.

17) When the temperature falls below zero, it is important to note that you should keep the tool warm in a safe and convenient way.

If you fail to do this, make the tool get warm according to the following procedure.

1) Control air pressure in the range of 40psi to 70psi.

2) Remove all the fasteners loaded in the tool.

3) Connect the airline to the tool and try mock drive a fastener.

- Keep pressure low enough to operate the tool in a proper way.

- Operate it slowly to let the actuator get warm.

- Piston operation helps bumper and O-ring maintain the original elasticity.

APPLICATIONS

- Finish and Trim (interior and exterior)

- Decorative Trim

- Cabinets

- Case Backs

- Molding

- Mirror and Picture Frames

- Paneling

INSTRUCTIONS FOR OPERATION

■ BE SURE TO READ THE SAFETY INSTRUCTION BEFORE USING THIS TOOL

■ PREPARATIONS

- 1) Be sure to put on personal protective equipment for example goggles, earplugs, safety cap before using this tool.
- 2) Be sure to use an air compressor authorized by the safety certification authority as a pressure source for operating this tool within the optimum range of pressure (58~100psi).
- 3) Make sure that this tool has no trouble about the safety device, the trigger, fasteners such as bolts, and so on.
- 4) Inject three or four drops of oil used exclusively for a tool into the air plug before using this tool. (Do this regularly once a day if possible.)
- 5) Check the airline and the air connector for damage and don't use longer airline than necessary (over 17ft).

PRELIMINARY CHECKUP

- 1) To give a checkup to the tool, adjust the operating pressure to 58 psi (4 bar) before air connection.
- 2) Keep pressure low as far as it may cause no trouble in operation within the optimum range of pressure according to hardness of the working plane and length of fasteners.

LOADING NAILS

WARNING!

Turn the muzzle downward and never pull the trigger in loading or unloading nails.

1) Pull the magazine backward with the click lever pressed.

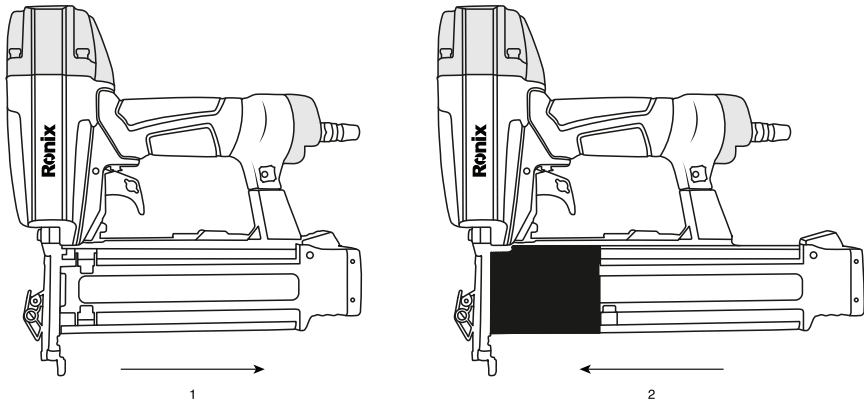

2) Load nails from the side of the magazine.

3) Keep pushing the magazine until it is fixed in the click lever.

UNLOADING NAILS

1) Pull the magazine backward with the click lever pressed.

2) Unload nails from the side of the magazine.

3) Keep pushing the magazine until it is fixed in the click lever.

MAINTENANCE AND INSPECTION

Be sure to read the safety instruction before inspecting or maintaining this tool.

⚠ WARNING!

Be sure to disconnect the air line before clearing jam, or repairing or inspecting the tool.

■ CLEARING A JAM

If jam occurs during the nailing process, clear it according to the following procedure.

- 1) Disconnect the air line from the tool.
- 2) Unload nails left in the magazine.
- 3) Open the guide cover B.
- 4) Use a long nose to remove a nail caught in.

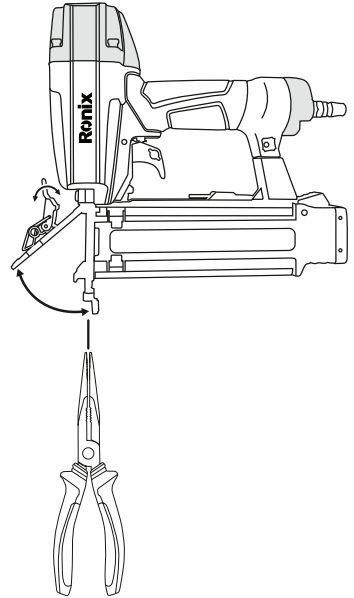

⚠ CAUTION:

- After clearing jam, make sure that the product has no trouble before using it.
- If jam or other factors damage main parts, it can prevent normal operation.
- If any trouble occurs, stop using the tool and ask a nearby A/S center or a distributor for A/S.

INSPECTING THE MAGAZINE

- 1) Disconnect the air line from the tool.
- 2) Inspect if the inside of the magazine is cleared or damaged. (Dust or alien substances such as pieces of wood in the operation body of the pusher within the magazine can prevent smooth operation.)

STORING

1) When not in use for an extended period, apply a thin coat of the

Practice	Reason	Method
Drain air line filter daily	Prevent accumulation of moisture and dirt.	Open manual petcock.
Keep lubricator filled.	Keep the tool lubricated	Fill with RONIX SERVICE pneumatic tool lubricant.
Clean magazine and feeder mechanism.	Prevent a jam & Dry fire.	Blow clean daily.
Lubricate the Tool after nailing.	Extend the tool life.	Supply 3~4 drops of lubricant into the tool.
Drain air compressor.	Keep the tool operated properly.	Open petcock on air compressor tank.

lubricant to the steel parts to avoid rust.

2) Do not store the tool in a cold weather environment. Keep the tool in

Problem	Check Method	Correction
Tool operates, but no nail is driven.	Check air pressure.	Reduce air pressure. (58~100psi)
	Check for a jam.	Clean a jam. (Refer to 4-1)
	Check for proper nail.	Use only recommended nails.
Tool operates, but no nail is driven.	Check air line & Plug	Check for air line connection and damage to fitting part (Change it in case of damage)
	Check for abnormality in head valve	Change O-ring in case of damage
	Check air pressure.	Reduce air pressure. (58~100psi)
	Check position Piston set	Readjust.
	-	Supply of lubricant into the tool.
	Driver blade worn or damaged?	Part change (Contact RONIX SERVICE or Distributor)
	Piston O-ring worn or damaged?	-
	Check air pressure.	Reduce air pressure. (58~100psi)
	Check air pressure.	Reduce air pressure. (58~100psi)
	Check for proper nail.	Use only recommended nails.
	-	Supply of lubricant into the tool.
	Piston O-ring cut or heavily worn?	Part change. (Contact RONIX SERVICE or Distributor)
	Check air pressure.	Reduce air pressure. (58~100psi)
	Check inside diameter of air hose.	Use larger air hose.

Ronix[®]
Premium Quality

www.ronixtools.com