

Ronix[®]

Premium Quality

AIR DIE GRINDER KIT (16PCS) RA-1802

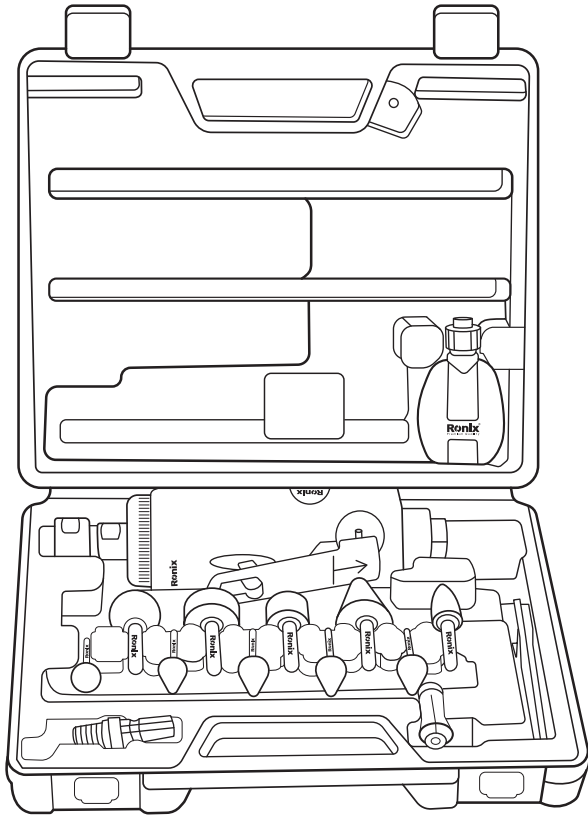

SPECIFICATIONS

Model	RA-1802
Power source	Air
No-load Speed	22000 RPM
Collet Size	6mm
Noise level	94db
Air inlet size	1/4"
Air pressure	90Psi
Material	Aluminum
Weight	0.604Kg
Supplied in	BMC+ color sleeve
Includes	2 pcs wrenches 10 pcs grinding stones 1 pc coupler 1 pc blow case 1 pc 1/8"(3mm) collet 1 pc oil-pot

PARTS LIST

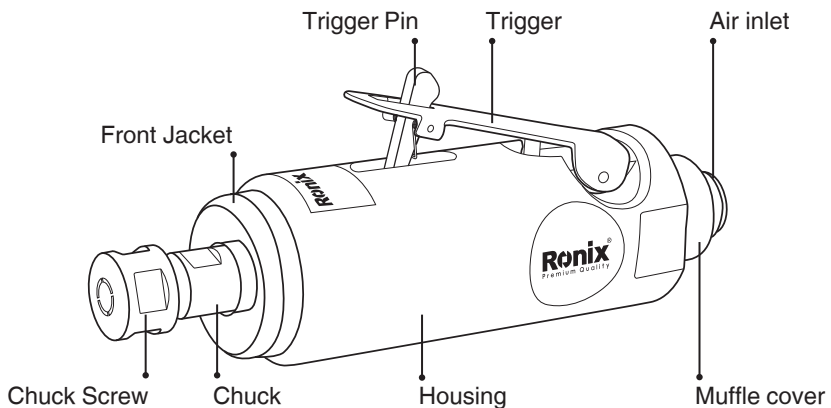

⚠ WARNING:

- Upon receipt of the product, read and follow all safety rules, operating instructions before first use it. And retain this manual for future reference.

⚠ RESIDUAL RISKS

Even when the tool is used as prescribed it is not possible to eliminate all residual risk factors. The following hazards may arise in connection with the tool's construction and design:



Damage to lungs if an effective dust mask is not worn.



Damage to hearing if effective hearing protection is not worn.

- Health defects resulting from vibration emission if the power tool is being used over longer period of time or not adequately managed and properly maintained.



Wear eye protection

GENERAL SAFETY RULES

- For multiple hazards, read and understand the safety instructions before installing, operating, repairing, maintaining, changing accessories on, or working near the die grinder. Failure to do so can result in serious bodily injury.

- Only qualified and trained operators should install, adjust or use the die grinder.

- Do not modify this die grinder. Modifications can reduce the effectiveness of safety measures and increase the risks to the operator.

- Do not discard the safety instructions; give them to the operator.

- Do not use the die grinder if it has been damaged.

- Tools shall be inspected periodically to verify that the ratings and markings required by this part of ISO 11148 are legibly marked on the tool. The employer/user shall contact the manufacturer to obtain

replacement marking labels when necessary.

PROJECTILE HAZARDS

- Be aware that failure of the workpiece or accessories, or even of the inserted tool itself can generate high velocity projectiles.
- Always wear impact-resistant eye protection during operation of the die grinder or when changing accessories on the tool. The grade of protection required should be assessed for each use.
- Ensure that the workpiece is securely fixed.
- Check regularly that the speed of the die grinder is not higher than that marked on it. These speed checks shall be carried out without the abrasive product mounted and in accordance with the instructions given by the manufacturer.
- Ensure that sparks and debris resulting from use do not create a hazard.
- Disconnect the grinder from the energy supply before changing abrasive product and servicing.
- The risks to others should also be assessed at this time.

ENTANGLEMENT HAZARDS

- Choking, scalping and/or lacerations can occur if loose clothing, personal jewelry, neck wear, hair or gloves are not kept away from the tool and accessories.

OPERATING HAZARDS

- Avoid contact with the rotating spindle and inserted tool to prevent cutting of hands and other body parts.
- Use of the tool can expose the operator's hands to hazards, including cuts and abrasions and heat. Wear suitable gloves to protect hands.
- Operators and maintenance personnel shall be physically able to handle the bulk, weight and power of the tool.
- Hold the tool correctly; be ready to counteract normal or sudden movements and have both hands available.

- Maintain a balanced body position and secure footing.
- Release the start and stop device in the case of an interruption of the energy supply.
- Use only lubricants recommended by the manufacturer.
- Personal protective safety glasses shall be used; suitable gloves and protective clothing are recommended.
- A rotary tool shall not be operated at a speed exceeding the rated speed.
- For overhead work, wear a safety helmet.
- Be aware that there is a running on of the rotary inserted tool after the start and stop device has been released.
- Warnings shall be given against the risk of explosion or fire due to the material being processed.

■ REPETITIVE MOTIONS HAZARDS

- When using a die grinder to perform work-related activities, the operator can experience discomfort in the hands, arms, shoulders, neck or other parts of the body.
- While using a die grinder, the operator should adopt a comfortable posture whilst maintaining a secure footing and avoiding awkward or off-balance postures. The operator should change posture during extended tasks; this can help avoid discomfort and fatigue.
- If the operator experiences symptoms such as persistent or recurring discomfort, pain, throbbing, aching, tingling, numbness, burning sensations or stiffness, these warning signs should not be ignored. The operator should tell the employer and consult a qualified health professional.

■ ACCESSORY HAZARDS

- Disconnect the die grinder from the energy supply before fitting or changing the inserted tool or accessory.
- Use only sizes and types of accessories and consumables that are recommended by the die grinder.

manufacturer; do not use other types or sizes of accessories or consumables.

- Avoid direct contact with the inserted tool during and after use as it can be hot or sharp.
- The maximum operating speed of the inserted tool shall equal or exceed the rated speed marked on the tool.
- Never mount a grinding wheel, cut-off wheel or router cutter on a die grinder. A grinding wheel that bursts can cause very serious injury or death.
- Do not use mounted wheels which are chipped or cracked or which could have been dropped.
- Use only permitted inserted tools of the correct shaft diameter.
- Pay attention to the fact that the permitted speed of the mounted point has to be lowered due to the increase of the length of the shaft between the end of the collet and the mounted point (overhang). Make sure that the minimum gripping length of 10mm is observed.
- Be aware of the risk of mismatching the diameter of the shaft of the mounted point and that of the collet.

WORKPLACE HAZARDS

- Dust and fumes generated when using die grinders can cause ill health (for example cancer, birth defects, asthma and/or dermatitis); risk assessment and implementation of appropriate controls for these hazards are essential.
- Risk assessment should include dust created by the use of the tool and the potential for disturbing existing dust.
- Operate and maintain the die grinder as recommended in these instructions, to minimize dust or fume emissions.
- Direct the exhaust so as to minimize disturbance of dust in a dust filled environment.
- Where dust or fumes are created, the priority shall be to control them at the point of emission.

- All integral features or accessories for the collection, extraction or suppression of airborne dust or fumes should be correctly used and maintained in accordance with the manufacturer's instructions.
- Select, maintain and replace the consumable/inserted tool as recommended in the instructions, to prevent an unnecessary increase in dust or fumes.
- Use respiratory protection in accordance with the employer's instructions and as required by occupational health and safety regulations.
- Working in certain materials creates emission of dust and fumes, causing a potentially explosive environment.

■ NOISE HAZARDS

- Exposure to high noise levels can cause permanent, disabling hearing loss and other problems, such as tinnitus (ringing, buzzing, whistling or humming in the ears). Therefore, risk assessment and implementation of appropriate controls for these hazards are essential.
- Appropriate controls to reduce the risk may include actions such as damping materials to prevent work pieces from "ringing".
- Use hearing protection in accordance with employer's instructions and as required by occupational health and safety regulations.
- Operate and maintain the die grinder as recommended in the instruction handbook, to prevent an unnecessary increase in the noise level.
- Select, maintain and replace the consumable/inserted tool as recommended in the instruction handbook, to prevent an unnecessary increase in noise.
- If the die grinder has a silencer, always ensure that it is in place and in good working order when the die grinder is being operated.

■ VIBRATION HAZARDS

- Exposure to vibration can cause disabling damage to the nerves and blood supply of the hands and arms.
- Wear warm clothing when working in cold conditions and keep your hands warm and dry.

- If you experience numbness, tingling, pain or whitening of the skin in your fingers or hands, stop using the die grinder, tell your employer and consult a physician.
- Operate and maintain the die grinder as recommended in the instruction handbook, to prevent an unnecessary increase in vibration levels.
- Select, maintain and replace the consumable/inserted tool as recommended in the instruction handbook, to prevent an unnecessary increase in vibration levels.
- Support the weight of the tool in a stand, tensioner or balancer if possible.
- Hold the tool with a light but safe grip, taking account of the required hand reaction forces, because the risk from vibration is generally greater when the grip force is higher.
- An improperly mounted or damaged inserted tool can cause excessive vibration levels.

■ ADDITIONAL SAFETY INSTRUCTIONS FOR PNEUMATIC POWER TOOLS

- Air under pressure can cause severe injury:
 - always shut off air supply, drain hose of air pressure and disconnect tool from air supply when not in use, before changing accessories or when making repairs.
- never direct air at yourself or anyone else.
- Whipping hoses can cause severe injury. Always check for damaged or loose hoses and fittings.
- Whenever universal twist couplings (claw couplings) are used, lock pins shall be installed and whip check safety cables shall be used to safeguard against possible hose-to-tool connection failure.
- Do not exceed the maximum air pressure stated on the tool.
- Never carry an air tool by the hose.

IMPORTANT SAFETY RULES

- 1- When grinding always wear safety goggles, an appropriate face mask or respiratory equipment.
- 2- Always ensure machine is switched off before connecting to air supply.
- 3- Disconnect any machine from the air supply before changing accessories and before servicing any type of machine.
- 4- Always keep your air tool clean and lubricated. Daily lubrication is essential to avoid internal corrosion and possible failure.
- 5- Do not wear watches, rings bracelets or loose clothing when using air tools.
- 6- Using only light weight coil hoses from a tool to the wall or compressor coupling.
- 7- Do not overload the machine. Allow the tool to operate at its optimum speed for maximum efficiency.
- 8- Do not increase the air pressure above the manufacturers recommended level, as excessive overload can cause the machine casing to split. Also this creates excessive wear on moving parts and possible failure.
- 9- In the interests of safety and possible damage to the machine/operator, always ensure that the machine has stopped before putting it down after use.
- 10- Always ensure that the work piece is firmly secured leaving both hands free to control the machine.
- 11- Always ensure that the accessories are rated/designed for use with the machine. Also correctly and securely fastened before connecting the machine to the air supply.
- 12- When grinding always wear an appropriate face mask or respiratory equipment.

OPERATING INSTRUCTION

Lever lock throttle for safety. Air die grinder is ideal for light weld, grinder, porting and polishing applications. Durable, lightweight composite

housing design also helps reduce vibration.

■AIR SUPPLY

- 1- Ensure air valve (or trigger) in the “off “position before connecting to the air supply.
- 2- You will require an air pressure of 90 Psi, and an air flow according to specification.

▲WARNING!

- 3- Ensure the air supply is clean and does not exceed 90Psi while operating the tool. Too high and air pressure and unclean air will shorten the product life due to the excessive wear, and may be dangerous causing damage or personal injury.
- 4- Drain the air tank daily. Water in the air line will damage the tool.
- 5- Clean air inlet filter weekly.
- 6- Line pressure should be increased to compensate for unusually long air hoses (over 8 meters). The hose diameter should be 3/8".
- 7- Keep hose away from heat, oil and sharp edges. Check hose for wear, and make certain that all connections are secure.

■LUBRICATION

An automatic in line filter regulator lubricator is recommended (Fig1) as it increases tool life and keeps the tool in sustained operation. The in-line lubricator should be regularly checked and filled with air tool oil. Proper adjustment of the in line lubricator is performed by placing a sheet of paper next to the exhaust ports and holding the throttle open approximately 30 seconds. The lubricator is properly set when a light stain of oil collects on the paper. Excessive amounts of oil should be avoided.

- In the event that it becomes necessary to store the tool for an extended period of time (overnight, weekend, etc.), it should receive a generous amount of lubrication at that time. The tool should be run for approximately 30 seconds to ensure oil has been evenly distributed

throughout the tool. The tool should be stored in a clean and dry environment.

- It is most important that the tool be properly lubricated by keeping the airline lubricator filled and correctly adjusted. Without proper lubrication the tool will not work properly and parts will wear prematurely.
- Use the proper lubricant in the air line lubricator. The lubricator should be of low air flow or changing air flow type, and should be kept filled to the correct level. Use only recommended lubricants, specially made for pneumatic applications. Substitutes may harm the rubber compounds in the tools O-rings and other rubber parts.

⚠ IMPORTANT!!!

If a filter/regulator/lubricator is not installed on the air system, air operated tools should be lubricated at least once a day or after 2 hours work with 2 to 6 drops of oil, depending on the work environment, directly through the male fitting in the tool housing.

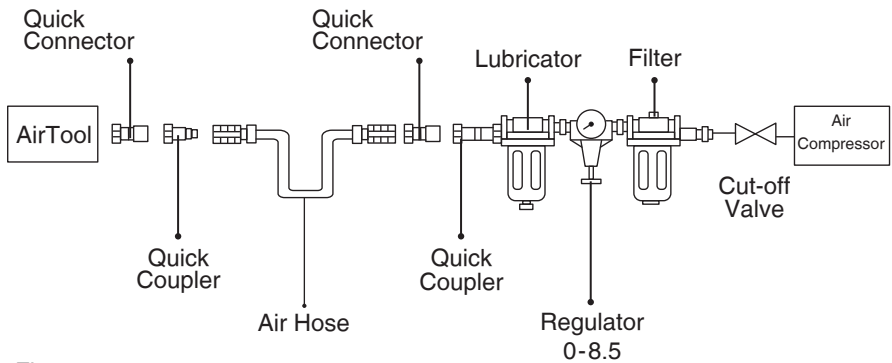

Fig 1

LOADING AND OPERATION

⚠ WARNING:

Ensure you read, understand and apply safety instructions before use.

- 1- Connect the tool to the air hose.

2- Press the trigger to operate the tool.

3- The flow of air may be regulated by adjusting flow valve at the base of the handle.

4- Ensure the air supply is clean and does not exceed 90 Psi while operating the tool. Too high an air pressure and unclean air will shorten the product life due to excessive wear, and may be dangerous causing damage or personal injury.

DO NOT use any additional force upon the tool.

DO NOT allow tool to free run for an extended period of time as this will shorten its life.

Turn on the air compressor and allow it to build up pressure once all of jobs done. Adjust the air compressor's regulator or the supply line regulator to 90PSI. Squeeze trigger gently.

 **WARNING:**

Disconnect tool from air supply before changing accessories, servicing or performing

maintenance. Replace or repair damaged parts. Use genuine parts only. Non-authorized parts may be dangerous.

1- Lubricate the air tool daily with a few drops of air tool oil dripped into the air inlet.

2- DO NOT use worn, or damaged tool.

3- Loss of power or erratic action may be due to the following: a) Excessive drain on the air line. Moisture or restriction in the air pipe. Incorrect size or type of hose connectors. To remedy check the air supply.

b) Grit or gum deposits in the tool may also reduce performance. If your model has an air strainer (located in the area of the air inlet), remove the strainer and clean it.

4- When not in use, disconnect from air supply, clean tool and store in a safe, dry, childproof location.

TROUBLE SHOOTING

The following form lists the common operating system with problem and solutions. Please read the form carefully and follow it.

WARNING:

If any of the following symptoms appears during your operating, stop using the tool immediately, or serious personal injury could result. Only a qualified persons or an authorized service center can perform repairs or replacement of tool.

- Disconnect tool from air supply before attempting repair or adjustment. When replacing O-rings or Cylinder, lubricate with air tool oil before assembly.

PROBLEMS	POSSIBLE CAUSES	REMEDIES
- Tool runs at normal speed but loses under load.	- Motor parts worn. - Cam clutch worn or sticking due to lack of lubricant.	- Lubricating clutch housing. - Check for excess clutch oil. Clutch cases need only be half full. Over filling can cause drag on highspeed clutch parts, ie. a typical oiled/ lubricated wrench requires 1/2 ounce of oil. - GREASE LUBRICATED: NOTE: Heat usually indicates insufficient grease in chamber. Severe operating conditions may require more frequent lubrication.

<p>Tool runs slowly. Air flows slightly from exhaust</p>	<ul style="list-style-type: none"> - Motor parts jammed with dirt particles - Power regulator in closed position - Air flow blocked by dirt. 	<ul style="list-style-type: none"> - Check air inlet filter for blockage. - Pour air tool lubricating oil into air inlet as per instructions. - Operate tool in short bursts quickly reversing rotation back and forth where applicable. - Repeat above as needed.
<p>Tools will not run. Air flows freely from exhaust</p>	<p>One or more motor vanes stuck due to material build up.</p>	<ul style="list-style-type: none"> - Pour air tool lubricating tool into air inlet. - Operate tool in short bursts of forward and/or reverse rotation where applicable. - Tap motor housing gently with plastic mallet. - Disconnect supply. Free motor
<p>Tool will not shut off</p>	<p>O-rings throttle valve dislodged from seat inlet valve.</p>	<p>Replace O-ring.</p>



www.ronixtools.com