

Ronix[®]

Premium Quality

AIR HAMMER KIT RA-1701

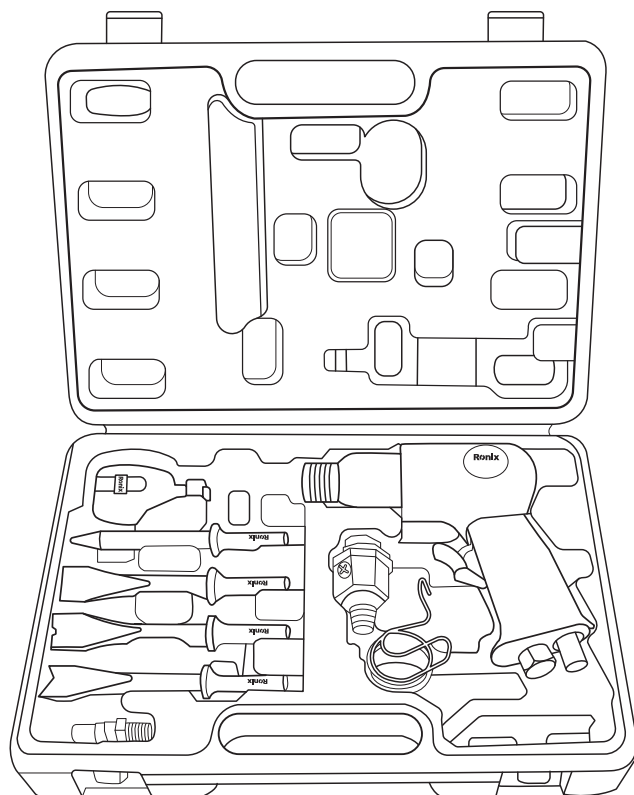

www.ronixtools.com



TECHNICAL SPECIFICATION

Model	RA-1701
Power Source	Air
Frequency	4500BPM
Piston Stroke	43mm
Air Pressure	90Psi
Air Inlet Size	1/4"
Noise Level	96.9db
Maximum Bit Holder	10mm
Speed	4500BPM
Material	Aluminum
Net Weight	1Kg
Total Weight	2Kg
Supplied in	BMC
Include	1pc oil pot 4pcs chisels 1pc spring 1pc quick coupler 1pc mini oiler

PART LIST

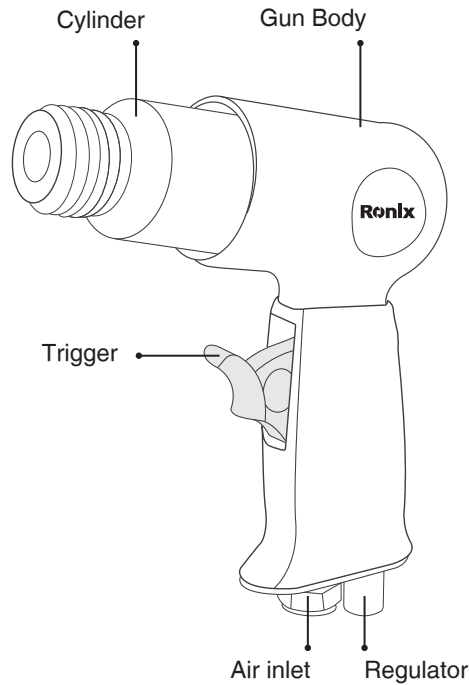

IMPORTANT SAFETY RULES

- 1- Always wear safety goggles, face mask or respiratory equipment.
- 2- Always ensure machine is switched off before connecting to air supply.
- 3- Disconnect any machine from the air supply before changing chisels and before servicing any type of machine.
- 4- Always keep your air tool clean and lubricated. Daily lubrication is essential to avoid internal corrosion and possible failure.
- 5- Do not wear watches, rings bracelets or loose clothing when using air tools.
- 6- Using only light weight coil hoses from a tool to the wall or compressor coupling.
- 7- Do not increase the air pressure above the manufacturers recommended

level, as excessive overload can cause the machine casing to split. Also, this creates excessive wear on moving parts and possible failure.

8- In the interests of safety and possible damage to the machine / operator, always ensure that the machine has stopped before putting it down after use.

9- Always ensure that the work piece is firmly secured leaving both hands free to control the machine.

10- Always ensure that the accessories such as blades, discs, sockets, etc. are rated/designed for use with the machine. Also, correctly and securely fastened before connecting the machine to the air supply.

OPERATING INSTRUCTION

WARNING!

- the power tools are not generally insulated for coming into contact with electric power sources;
- the power tools shall not be used in explosive atmospheres unless specially designed for that purpose;
- that unexpected tool movement or breakage of cutters may cause injuries;
- those unsuitable postures may not allow counteracting of normal or unexpected movement of the power tool;
- if the power tool is fixed to suspension device make sure that the fixation is secure;
- Be careful when working with tools to avoid cutting or cutting your body parts.
- Be careful not to throw out metal shavings when working with the tool.
- Be careful about the risk of whipping the compressor air hose.
- to observe that only lubricants recommended by the manufacturer shall be used
- release the start and stop switch of device in the case of an interruption of the energy supply.

DESCRIPTION

Hardened steel barrel and piston for less wear and longer life, lightweight aluminum pistol grip housing, front exhaust, 43mm air hammer set includes the chisels (round & hex), a retainer spring and a quick coupler, ideal for general cutting, chipping and scraping.

AIR SUPPLY

- 1- Ensure air valve (or trigger) is in the “off” position before connecting to the air supply.
- 2- You will require an air pressure of 90psi, and an air flow according to specification.

WARNING!

- 3- Ensure the air supply is clean and does not exceed 90psi while operating the tool. Too high an air pressure and unclean air will shorten the product life due to excessive wear, and may be dangerous causing damage or personal injury.
- 4- Drain the air tank daily. Water in the airline will damage the tool.
- 5- Clean air inlet filter weekly.
- 6- line pressure should be increased to compensate for unusually long air hoses (over 8 meters). The hose diameter should be 3/8”.
- 7- Keep hose away from heat, oil and sharp edges. Check hose for wear, and make certain that all connections are secure.

LUBRICATION

An automatic in line filter/regulator/lubricator is recommended (Fig1) as it increases tool life and keeps the tool in sustained operation. The in-line lubricator should be regularly checked and filled with air tool oil. Proper adjustment of the in-line lubricator is performed by placing a sheet of paper next to the exhaust ports and holding the throttle open approximately 30 seconds. The lubricator is properly set when a light stain of oil collects on the paper. Excessive amounts of oil should be avoided.

In the event that it becomes necessary to store the tool for an extended period of time (overnight, weekend, etc.), it should receive a generous amount of lubrication at that time. The tool should be run for approximately 30 seconds to ensure oil has been evenly distributed throughout the tool. The tool should be stored in a clean and dry environment.

It is most important the tool be properly lubricated by keeping the airline lubricator filled and correctly adjusted. Without proper lubrication the tool will not work properly and parts will wear prematurely.

use the proper lubricant in the air line lubricator. The lubricator should be of low air flow or changing air flow type, and should be kept filled to the correct level. Use only recommended lubricants, specially made for pneumatic applications. Substitutes may harm the rubber compounds in the tools O-rings and other rubber parts.

! IMPORTANT!!!

If a filter/regulator/lubricator is not installed on the air system, air operated tools should be lubricated at least once a day or after 2 hours work with 2 to 6 drops of oil, depending on the work environment, directly through the male fitting in the tool housing.

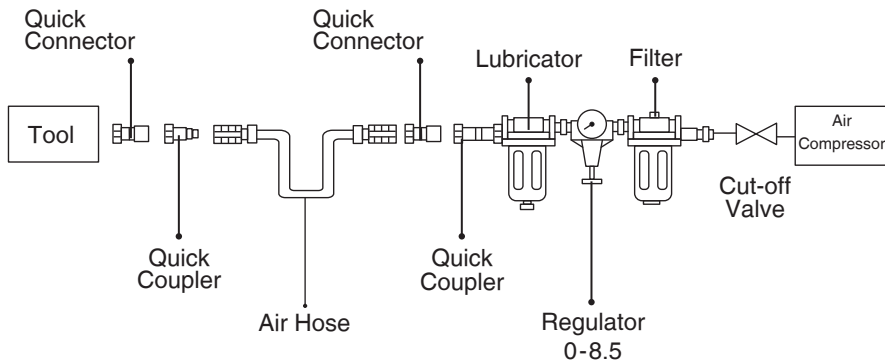

Fig 1

LOADING AND OPERATION

WARNING!

Ensure you read, understand and apply safety instructions before use.

- 1- Connect the tool to the air hose.
- 2- Press the trigger to operate the tool.
- 3- The flow of air may be regulated by adjusting flow valve at the base of the handle.
- 4- Ensure the air supply is clean and does not exceed 90psi while operating the tool. Too high an air pressure and unclean air will shorten the product life due to excessive wear, and may be dangerous causing damage or personal injury.

DO NOT use any additional force upon the tool.

DO NOT allow tool to free run for an extended period of time as this will shorten its life.

MAINTENANCE

WARNING!

Disconnect tool from air supply before changing accessories, servicing or performing maintenance. Replace or repair damaged parts. Use genuine parts only. Non-authorized parts may be dangerous.

- 1- Lubricate the air tool daily with a few drops of air tool oil dripped into the air inlet
- 2- DO NOT use worn, or damaged tool.
- 3- Loss of power or erratic action may be due to the following:
 - a) Excessive drain on the air line. Moisture or restriction in the air pipe. Incorrect size or type of hose connectors. To remedy check the air supply.
 - b) Grit or gum deposits in the tool may also reduce performance. If your model has an air strainer (located in the area of the air inlet), remove the strainer and clean it.
- 4- When not in use, disconnect from air supply, clean tool and store in a

safe, dry, childproof location.

TROUBLE SHOOTING

The following from lists the common operating system with problem and solutions. Please read the form carefully and follow it. Warning: if any the following symptoms appears during your operating, stop using the tool immediately, or serious personal injury could result. Only a qualified persons or an authorized service center can perform repairs or replacement of tool. Disconnect tool from air supply before attempting repair or adjustment. When replacing O-rings or Cylinder, lubricate with air tool oil before assembly.

PROBLEMS	POSSIBLE CAUSES	REMEDIES
Tool runs at normal speed but loses under load	- Cam clutch worn or sticking due to lack of lubricant.	- Lubricating clutch housing. - Check for excess clutch oil. Clutch cases need only be half full. Overfilling can cause drag on high-speed clutch parts. A typical oiled/lubricated wrench requires ½ ounce of oil. GREASE LUBRICATED: NOTE: Heat usually indicates insufficient grease in chamber. Severe operating conditions may require more frequent lubrication.
Tool runs slowly. Air flows slightly from exhaust	- Power regulator in closed position - Air flow blocked by dirt.	- Check air inlet filter for blockage. - Pour air tool lubricating oil into air inlet as per instructions. - Operate tool in short bursts quickly reversing rotation back and forth where applicable. - Repeat above as need.

<p>Tools will not run. Air flows freely from exhaust</p>	<p>- One or more motor vanes stuck due to material build up.</p>	<p>Pour air tool lubricating tool into air inlet. - Operate tool in short bursts or forward and/or reverse rotation where applicable. - Disconnect supply</p>
<p>Tool will not shut off</p>	<p>- 'O' rings throttle valve dislodged from seat inlet valve.</p>	<p>- Replace 'O' ring.</p>

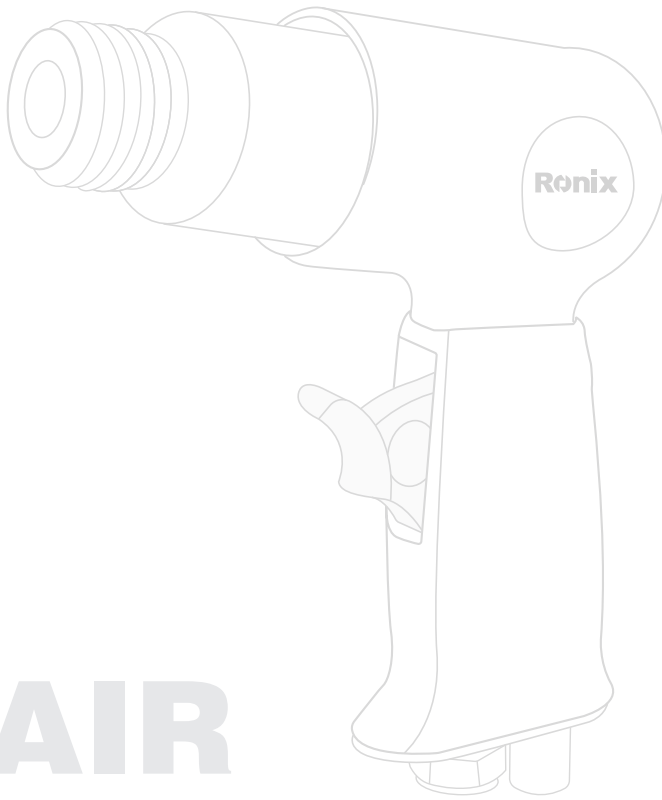

AIR HAMMER KIT



www.ronixtools.com