

Ronix[®]

Premium Quality

AIR IMPACT SCREWDRIVER RA-1301

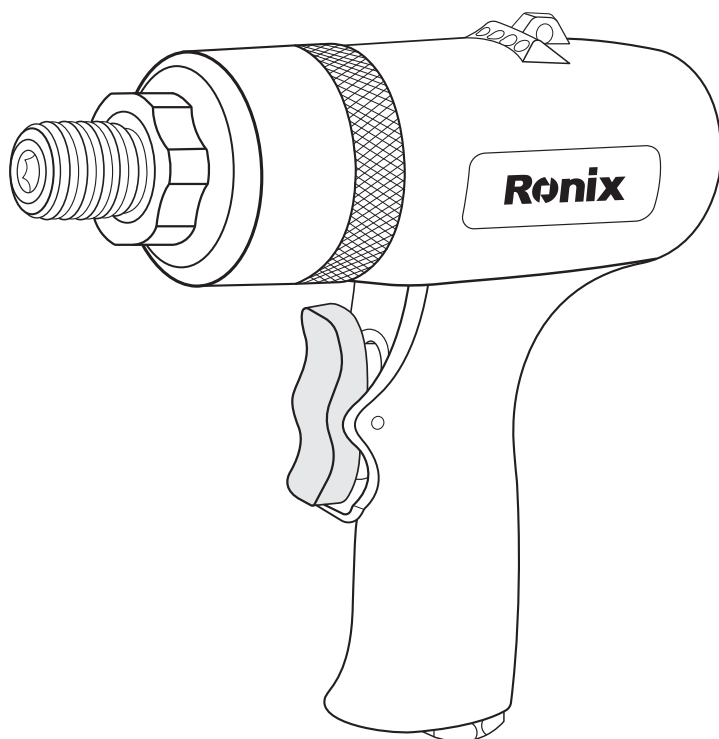

SPECIFICATIONS

Model	RA-1301
Head Style	hexagon
Max Torque	80ft.lb,108N.m
Working Pressure	90 Psi,0.63 MPa,6.3 Bar
Drive Anvil Size	1/4" ,6.35mm
No-Load Speed	9000RPM
Bolt Size	3-10mm
Air Inlet (NPT)	1/4",6.35mm
Air Hose (ID)	3/8",9.52mm
Avg Air Consumption	4CFM,114L/min
Overall Length	5.31",135mm
Weight	1.4Kg
Handle Type	Pistol Grip
Capacity Standard Screw	0.12 to 0.39" 3 to 10mm
Supplied in	Color box
Housing Material	aluminum
Included Components	1pc connector, 1pc oil bottle, 1pc cross screwdriver head

PARTS LIST

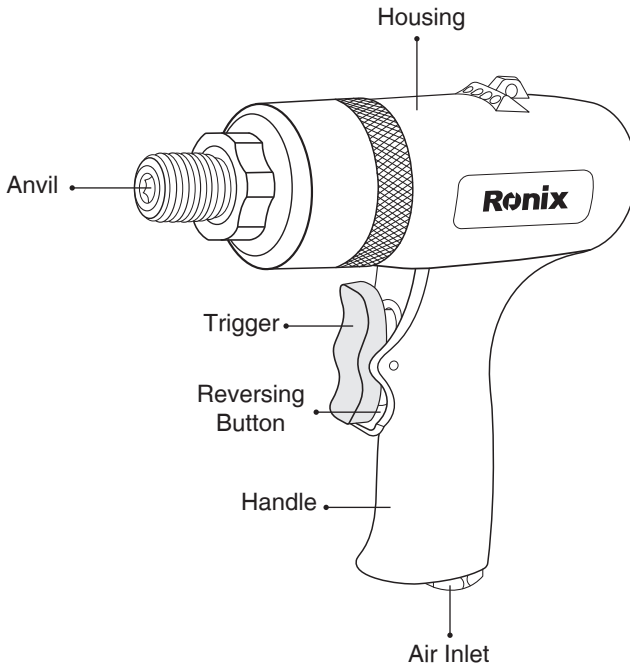

IMPORTANT SAFETY RULES

Even when the tool is used as prescribed it is not possible to eliminate all residual risk factors. The following hazards may arise in connection with the tool's construction and design:

- 1- Damage to lungs if an effective dust mask is not worn.
- 2- Damage to hearing if effective hearing protection is not worn.
- 3- Health defects resulting from vibration emission if the power tool is being used over longer period of time or not adequately managed and properly maintained.
- 4- Wear eye protection.
- 5- Always ensure machine is switched off before connecting to air supply.

- 6- Disconnect any machine from the air supply before changing blades or discs, and before servicing any type of machine.
- 7- Always keep your air tool clean and lubricated. Daily lubrication is essential to avoid internal corrosion and possible failure.
- 8- Do not wear watches, rings bracelets or loose clothing when using air tools.
- 9- Using only light weight coil hoses from a tool to the wall or compressor coupling. Do not fit quick change couplings onto the machine as vibration can cause the coupling to fail.
- 10- Do not overload the machine. Allow the tool to operate at its optimum speed for maximum efficiency.
- 11- Do not increase the air pressure above the manufacturers recommended level, as excessive overload can cause the machine casing to split. Also, this creates excessive wear on moving parts and possible failure.
- 12- In the interests of safety and possible damage to the machine/operator, always ensure that the machine has stopped before putting it down after use.
- 13- Always ensure that the work piece is firmly secured leaving both hands free to control the machine.
- 14- Always ensure that the accessories such as blades, discs, sockets, etc. are designed for use with the machine. Also, correctly and securely fastened before connecting the machine to the air supply.

OPERATING INSTRUCTION

AIR SUPPLY

- 1- Ensure wrench air valve (or trigger) is in the “off” position before connecting to the air supply.
- 2- You will require an air pressure of 90psi, and an air flow according to specification.
- 3- Drain the air tank daily. Water in the airline will damage the wrench.

- 4- Clean air inlet filter weekly.
- 5- Line pressure should be increased to compensate for unusually long air hoses (over 8 meters). The hose diameter should be 3/8" I.D.
- 6- Keep hose away from heat, oil and sharp edges. Check hose for wear, and make certain that all connections are secure.

LUBRICATION

An automatic in-line filter-regulator-lubricator is recommended as it increases tool life and keeps the tool in sustained operation. The in-line lubricator should be regularly checked and filled with air tool oil. Proper adjustment of the in-line lubricator is performed by placing a sheet of paper next to the exhaust ports and holding the throttle open approximately 30 seconds. The lubricator is properly set when a light stain of oil collects on the paper. Excessive amounts of oil should be avoided.

In the event that it becomes necessary to store the tool for an extended period of time (overnight, weekend, etc.), it should receive a generous amount of lubrication at that time. The tool should be run for approximately 30 seconds to ensure oil has been evenly distributed throughout the tool. The tool should be stored in a clean and dry environment.

- It is most important that the tool be properly lubricated by keeping the airline lubricator filled and correctly adjusted. Without proper lubrication the tool will not work properly and parts will wear prematurely.
- Use the proper lubricant in the air line lubricator. The lubricator should be of low air flow or changing air flow type, and should be kept filled to the correct level. Use only recommended lubricants, specially made for pneumatic applications. Substitutes may harm the rubber compounds in the tools O-rings and other rubber parts.

IMPORTANT!

If a filter/regulator/lubricator is not installed on the air system, air operated tools should be lubricated at least once a day or after 2 hours work with 2

to 6 drops of oil, depending on the work environment, directly through the male fitting in the tool housing.

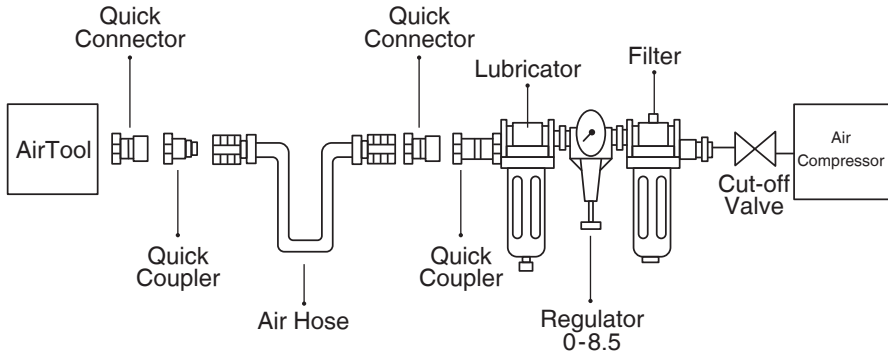

Fig 4

LOADING AND OPERATION

ENSURE YOU READ, UNDERSTAND AND APPLY SAFETY INSTRUCTIONS BEFORE USE.

- 1- Only use impact sockets which are specifically designed for use with an impact wrench.
 - 2- Connect the wrench to the air hose.
 - 3- Place the socket over the subject nut and depress the trigger to operate the wrench.
 - 4- To change direction, push the button at the top of the handle. Direction of. R. for reverse and "F" for forward.
 - 5- The flow of air may be regulated by adjusting flow valve at the base of the handle. DO NOT use any additional force upon the wrench in order to remove a nut.
- DO NOT allow wrench to free run for an extended period of time as this will shorten its life.

MAINTENANCE

Disconnect wrench from air supply before changing accessories, servicing or performing maintenance. Replace or repair damaged parts. Use genuine parts only. Non-authorized parts may be dangerous.

1- Lubricate the air wrench daily with a few drops of air tool oil dripped into the air inlet.

2- DO NOT use worn, or damaged sockets.

3- Loss of power or erratic action may be due to the following:

a) Excessive drain on the air line. Moisture or restriction in the air pipe. Incorrect size or type of hose connectors. To remedy check the air supply and follow instructions.

b) Grit or gum deposits in the wrench may also reduce performance. If your model has an air strainer (located in the area of the air inlet), remove the strainer and clean it.

4- When not in use, disconnect from air supply, clean wrench and store in a safe, dry, childproof location.

TROUBLE SHOOTING

The following form lists the common operating system with problem and solutions.

If any of the following symptoms appears during your operating, stop using the tool immediately, or serious personal injury could result. Only a qualified persons or an authorized service center can perform repairs or replacement of tool. Disconnect tool from air supply before attempting repair or adjustment. When replacing O-rings or Cylinder, lubricate with air tool oil before assembly.

PROBLEMS	POSSIBLE CAUSES	REMEDIES
Tool runs at normal speed but loses under load	<ul style="list-style-type: none"> - Motor parts worn. - Cam clutch worn or sticking due to lack of lubricant. 	<ul style="list-style-type: none"> - Lubricating clutch housing. - Check for excess clutch oil. Clutch cases need only be half full. <p>Overfilling can cause drag on high-speed clutch parts, ie. a typical oiled/lubricated wrench requires 1/2 ounce of oil.</p> <p>GREASE LUBRICATED: NOTE:</p> <p>Heat usually indicates insufficient grease in chamber. Severe operating conditions may require more frequent lubrication.</p>
Tool runs slowly. Air flows slightly from exhaust	<ul style="list-style-type: none"> Motor parts jammed with dirt particles - Power regulator in closed position - Air flow blocked by dirt. 	<ul style="list-style-type: none"> - Check air inlet filter for blockage. - Pour air tool lubricating oil into air inlet as per instructions. - Operate tool in short bursts quickly reversing rotation back and forth where applicable. - Repeat above as needed.
Tools will not run. Air flows freely from exhaust	<ul style="list-style-type: none"> - One or more motor vanes stuck due to material build up. 	<ul style="list-style-type: none"> - Pour air tool lubricating tool into air inlet. - Operate tool in short bursts of forward and/or reverse rotation where applicable. - Tap motor housing gently with plastic mallet. - Disconnect supply. Free motor by rotating drive shank manually where applicable
Tool will not shut off	<ul style="list-style-type: none"> - "O" rings throttle valve dislodged from seat inlet valve. 	<ul style="list-style-type: none"> - Replace "O" ring.
<p>Note: Repairs should be carried out by a qualified person.</p>		

Ronix[®]
Premium Quality

www.ronixtools.com