

Ronix[®]

Premium Quality

CORDLESS IMPACT WRENCH

8907

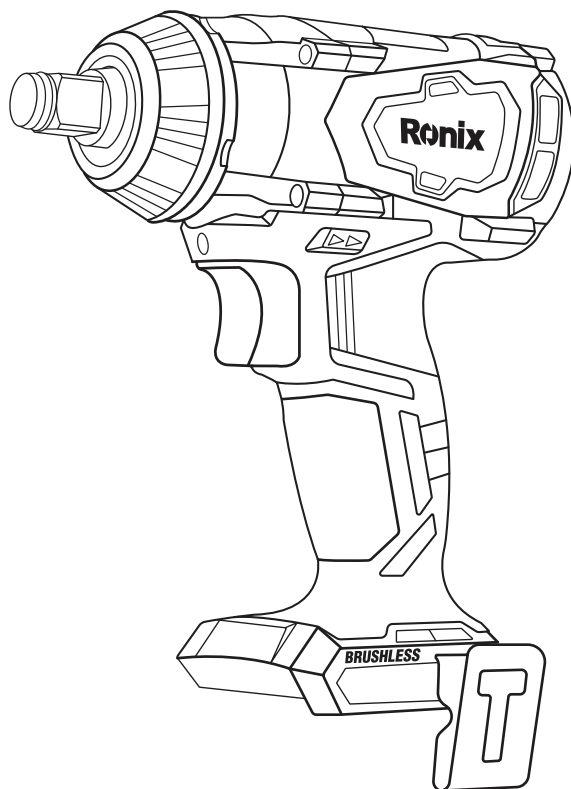

www.ronixtools.com

TECHNICAL SPECIFICATIONS

Model	8907
Max Torque	350NM
High Tensile Bolt	M10-M16
Standard Bolt	M10-M20
Impact Rate	0-1800 IPM 0-2500 IPM 0-3300 IPM
Battery Voltage	20V
Chuck Size	1/2" Square
Battery Chemistry	Lithium
No-Load Speed	0-1600 RPM 0-2000 RPM 0-2500 RPM
Weight	1.12Kg
Supplied In	Ronix color box

THIS PRODUCT DOES NOT INCLUDE BATTERIES OR CHARGER

USABLE BATTERIES FOR 8907

Ronix Model No.	Product
8990	20V battery pack, 2.0Ah Li-ion battery
8991	20V battery pack, 4.0Ah Li-ion battery

USABLE CHARGERS FOR 8907

Ronix Model No.	Product
8992	20V fast charger, Output:22V 2.2A
8993	20V fast charger, Output:22V 4.5A
8994	20V fast charger, Output:22V 4.5A (Dual Model)

PART LIST

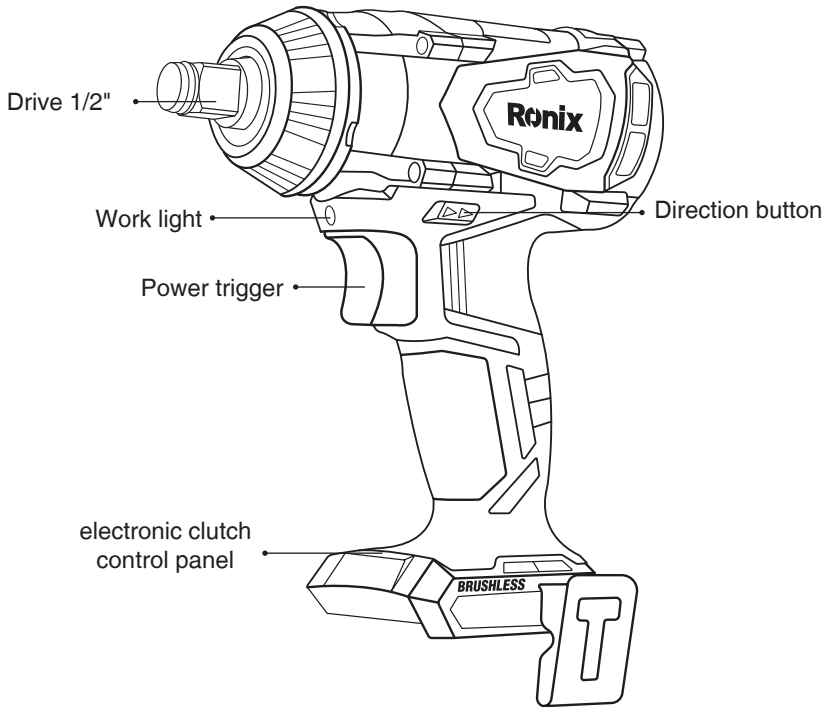

GENERAL POWER TOOL SAFETY RULES

⚠ WARNING!

- Read all safety warnings and all instructions. Failure to follow the warnings and instructions may result in electric shock, fire and/or serious injury.
- Save all warnings and instructions for future reference.
- The term «power tool» in the warnings refers to your mains-operated (corded) power tool or battery-operated (cordless) power tool.

■ WORK AREA SAFETY

- Keep work area clean and well lit. Cluttered or dark areas invite accidents.

-Do not operate power tools in explosive atmospheres, such as in the presence of flammable liquids, gases or dust. Power tools create sparks which may ignite the dust or fumes.

-Keep children and bystanders away while operating a power tool. Distractions can cause you to lose control.

■ ELECTRICAL SAFETY

-Power tool plugs must match the outlet. Never modify the plug in any way. Do not use any adapter plugs with earthed (grounded) power tools. Unmodified plugs and matching outlets will reduce risk of electric shock.

-Avoid body contact with earthed or grounded surfaces such as pipes, radiators, ranges and refrigerators. There is an increased risk of electric shock if your body is earthed or grounded.

-Do not expose power tools to rain or wet conditions. Water entering a power tool will increase the risk of electric shock.

-Do not abuse the cord. Never use the cord for carrying, pulling or unplugging the power tool. Keep cord away from heat, oil, sharp edges or moving parts. Damaged or entangled cords increase the risk of electric shock.

-When operating a power tool outdoors, use an extension cord suitable for outdoor use. Use of a cord suitable for outdoor use reduces the risk of electric shock.

-If operating a power tool in a damp location is unavoidable, use a ground fault circuit interrupter (GFCI) protected supply. Use of a GFCI reduces the risk of electric shock.

■ PERSONAL SAFETY

-Stay alert, watch what you are doing and use common sense when operating a power tool. Do not use a power tool while you are tired or under the influence of drugs, alcohol or medication. A moment of inattention while operating power tools may result in serious personal injury.

-Use personal protective equipment. Always wear eye protection. Protective equipment such as dust mask, non-skid safety shoes, hard

hat, or hearing protection used for appropriate conditions will reduce personal injuries.

-Prevent unintentional starting. Ensure the switch is in the off-position before connecting to power source and/or battery pack, picking up or carrying the tool. Carrying power tools with your finger on the switch or energizing power tools that have the switch on invites accidents.

-Remove any adjusting key or wrench before turning the power tool on. A wrench or a key left attached to a rotating part of the power tool may result in personal injury.

-Do not overreach. Keep proper footing and balance at all times. This enables better control of the power tool in unexpected situations.

-Dress properly. Do not wear loose clothing or jewelry. Keep your hair, clothing, and gloves away from moving parts. Loose clothes, jewelry or long hair can be caught in moving parts.

-If devices are provided for the connection of dust extraction and collection facilities, ensure these are connected and properly used. Use of dust collection can reduce dust-related hazards.

■ **POWER TOOL USE AND CARE**

-Do not force the power tool. Use the correct power tool for your application. The correct power tool will do the job better and safer at the rate for which it was designed.

-Do not use the power tool if the switch does not turn it on and off. Any power tool that cannot be controlled with the switch is dangerous and must be repaired.

-Disconnect the plug from the power source and/or the battery pack from the power tool before making any adjustments, changing accessories, or storing power tools. Such preventive safety measures reduce the risk of starting the power tool accidentally.

-Store idle power tools out of the reach of children and do not allow persons unfamiliar with the power tool or these instructions to operate the power tool. Power tools are dangerous in the hands of untrained users.

-Maintain power tools. Check for misalignment or binding of moving parts, breakage of parts and any other condition that may affect the power tool's operation. If damaged, have the power tool repaired before use. Many accidents are caused by poorly maintained power tools.

-Keep cutting tools sharp and clean. Properly maintained cutting tools with sharp cutting edges are less likely to bind and are easier to control.

-Use the power tool, accessories and tool bits etc. in accordance with these instructions, taking into account the working conditions and the work to be performed. Use of the power tool for operations different from those intended could result in a hazardous situation.

■ BATTERY TOOL USE AND CARE

-Recharge only with the charger specified by the manufacturer. A charger that is suitable for one type of battery pack may create a risk of fire when used with another battery pack.

-Use power tools only with specifically designated battery packs. Use of any other battery packs may create a risk of injury and fire.

-When battery pack is not in use, keep it away from other metal objects, like paper clips, coins, keys, nails, screws or other small metal objects that can make a connection from one terminal to another. Shorting the battery terminals together may cause burns or a fire.

-Under abusive conditions, liquid may be ejected from the battery; avoid contact. If contact accidentally occurs, flush with water. If liquid contacts eyes, additionally seek medical help. Liquid ejected from the battery may cause irritation or burns.

■ SERVICE

-Have your power tool serviced by a qualified repair person using only identical replacement parts. This will ensure that the safety of the power tool is maintained.

-Follow instruction for lubricating and changing accessories.

-Keep handles dry, clean and free from oil and grease.

CORDLESS IMPACT WRENCH SAFETY

⚠ WARNING!

- Always be sure you have a firm footing. Be sure no one is below when using the tool in high locations.
- Hold the tool firmly.
- Keep hands away from rotating parts.
- Do not leave the tool running. Operate the tool only when hand-held.
- Do not touch the drill bit or the work piece immediately after operation; they may be extremely hot and could burn your skin.
- Some material contains chemicals which may be toxic. Take caution to prevent dust inhalation and skin contact. Follow material supplier safety data.

⚠ WARNING!

Do not let comfort or familiarity with product (gained from repeated use) replace strict adherence to safety rules for the subject product. Misuse or failure to follow the safety rules stated in this instruction manual may cause serious personal injury.

IMPORTANT SAFETY INSTRUCTIONS FOR BATTERY CARTRIDGE

- Before using battery cartridge, read all instructions and cautionary markings on (1) battery charger, (2) battery, and (3) product using battery.
- Do not disassemble battery cartridge.
- If operating time has become excessively shorter, stop operating immediately. It may result in a risk of overheating, possible burns and even an explosion.
- If electrolyte gets into your eyes, rinse them out with clear water and seek medical attention right away. It may result in loss of your eyesight.

■ DO NOT SHORT THE BATTERY CARTRIDGE

1. Do not touch the terminals with any conductive material.
 2. Avoid storing battery cartridge in a container with other metal objects such as nails, coins, etc.
 3. Do not expose battery cartridge to water or rain. A battery short can cause a large current flow, overheating, possible burns and even a breakdown.
- Do not store the tool and battery cartridge in locations where the temperature may reach or exceed 50° C (122° F).
 - Do not incinerate the battery cartridge even if it is severely damaged or is completely worn out. The battery cartridge can explode in a fire.
 - Be careful not to drop or strike battery.
 - Do not use a damaged battery.

TIPS FOR MAINTAINING MAXIMUM BATTERY LIFE

- Charge the battery cartridge before completely discharged. Always stop tool operation and charge the battery cartridge when you notice less tool power.
- Never recharge a fully charged battery cartridge. Overcharging shortens the battery service life.
- Charge the battery cartridge with room temperature at 100C - 400C (500F - 1040F). Let a hot battery cartridge cool down before charging it.

FUNCTIONAL DESCRIPTION

CAUTION:

Always be sure that the tool is switched off and the battery cartridge is removed before adjusting or checking function on the tool.

INSTALLING OR REMOVING BATTERY CARTRIDGE

- To remove the battery cartridge, withdraw it from the tool while sliding the red button on the front of the cartridge.
- To insert the battery cartridge, align the tongue on the battery cartridge with the groove in the housing and slip it into place. Always insert it all the way until it locks in place with a little click.
- Do not use force when inserting the battery cartridge. If the cartridge does not slide in easily, it is not being inserted correctly.

FORWARD (CLOCKWISE) OPERATION:

The motor has an electronic clutch with three different forward speed settings: 1, 2, and 3 (low, medium and high).

The speed setting is adjustable by pushing the S button on the Electronic clutch control panel on the base of the tool. If the trigger is momentarily pushed the Electronic Clutch will be activated. If one green LED is illuminated, the motor is set to Speed 1. If two green LEDs are illuminated then the motor is set to speed 2 and three green LEDs for speed 3. Push the button marked S on the Electronic clutch control panel to cycle through the three speed settings and select the correct one for your specific application.

Speed	RPM	IPM	Max. Torque
1s Speed	0-1650	0-1800	200NM
2nd Speed	0-2200	0-2500	280NM
3rd Speed	0-2600	0-3300	350NM
Reverse	0-2600	0-3300	350NM

REVERSE (COUNTER CLOCKWISE) OPERATION:

The electronic clutch has two different reverse modes: Full Reverse and Auto Break. The Full Reverse mode is automatically activated when the direction switch (2) is put into the reverse position. No LEDs on the Electronic clutch control panel should be illuminated. This means that the clutch is set to full reverse mode. When the trigger is pushed the tool

will operate in reverse for as long as you hold down the trigger. The Auto Break function is engaged by pushing the B button on the Electronic clutch control panel (5). A red LED will illuminate in the third LED position to indicate that the Auto Break is engaged. When the trigger is pushed the tool will start hammering in reverse. As soon as the bolt breaks loose and there is no resistance the tool will immediately stop reverse motion. This feature is meant for controlled loosening of lug nuts without backing fully off the stud. Uncontrolled spinning can damage the treads on the end of the stud or bolt. To disengage break just push the B button one more time and the red LED will turn off. Your tool is again in the full reverse mode. **NOTICE:** Both reverse functions only operate with the electronic clutch in the third speed position. This feature is unavailable in speed one and two

MAINTENANCE

CAUTION:

- Always be sure that the tool is switched off and the battery cartridge is removed before attempting to perform inspection or maintenance.
- Never use gasoline, benzene, thinner, alcohol or the like. Discoloration, deformation or cracks may result.

NOTE:

To maintain product safety and reliability repairs, any other maintenance or adjustment should be performed by **Ronix Service** Authorized Service Centers, always using RONIX replacement parts.

Ronix[®]
Premium Quality

www.ronixtools.com