

Ronix[®]

Premium Quality

20V BRUSHLESS CORDLESS ROTARY HAMMER 3.5J

8679

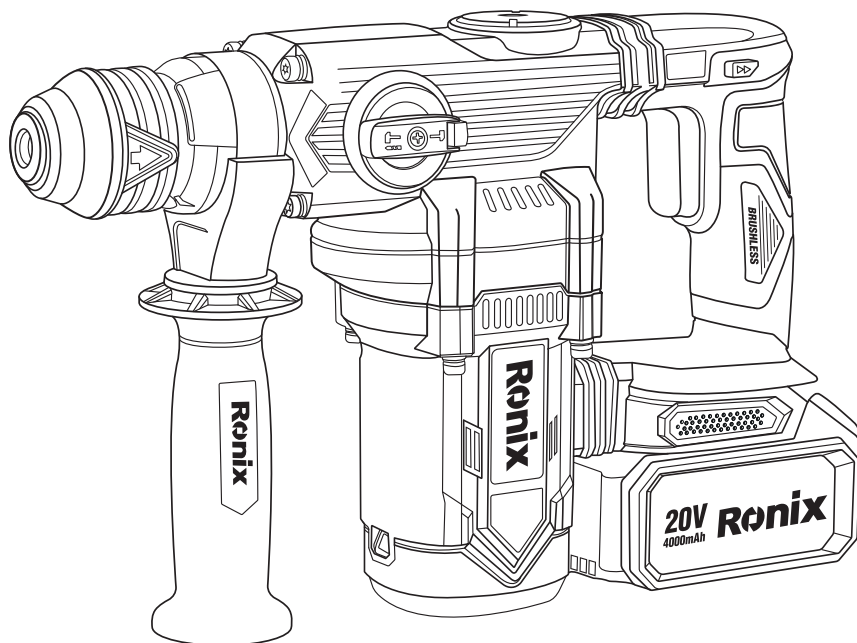

SPECIFICATION

Model	8679
Battery Type	Lithium-ion
Battery Capacity	4.0Ah/20V
Chuck Type	SDS-Plus
Chuck Size	Φ10mm
No-load Speed	0-1000RPM
Impact Joules	3.5J
Impact Rate	0-5400BPM
Max Capacity in Concrete	24mm
Dimensions	336×91×221mm
Body Material	PA6+GF30
Weight	4.26Kg (With 1pc Battery Pack)
Packaging	BMC
Include	2pcs Battery Packs 1pc Charger 1pc Auxiliary Handle 1pc Dust Cover

PART LIST

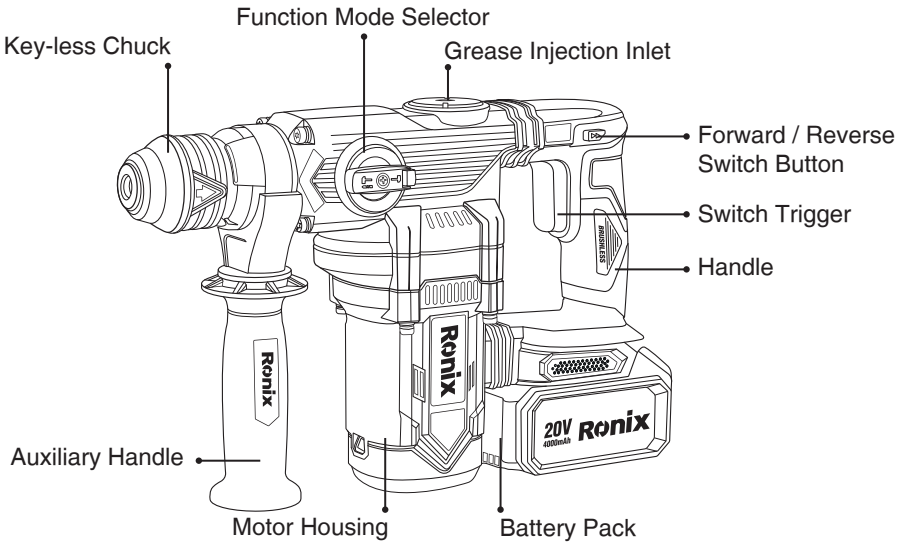

READ THE INSTRUCTION MANUAL

■ **PURPOSE:** This tool used For vibration operation on concrete, brick wall and stone. You can also use this tool to drilling on wood, metal, ceramic materials and plastics (normal drilling without vibration function). Read all safety warnings, instructions, and regulations provided with the electric tool. Failure to follow the instructions listed below may result in electric shock, fire and/or serious injury.

■ KEEP ALL WARNINGS AND INSTRUCTIONS FOR REFERENCE.

The term "electric tool" in the warning refers to a commercially available (wired) electric tool or a battery-powered (wireless) electric tool.

■ SAFETY OF WORKPLACE

1- Keep the workplace clean and bright. Disordered and dark places can cause accidents.

2- Do not operate electric tools in explosive environment, such as flammable liquid, gas or dust. Sparks generated by electric tools can ignite dust or gas.

3- Keep away from children and bystanders when operating electric tools. Lack of concentration will make you lose control of tools.

■ ELECTRICAL SAFETY

1- The plug of electric tool must match the socket. Never modify the plug in any way. Electric tools that need to be grounded cannot use any conversion plug. Unmodified plugs and matching sockets will reduce the risk of electric shock.

2- Avoid human contact with grounding surfaces, such as pipes, cooling fins and refrigerators. If you touch the ground surface, you will increase the risk of electric shock.

3- Do not expose electric tools to rain or damp environment. Water entering electric tools will increase the risk of electric shock.

4- Do not abuse the cord. Never carry, pull or unplug electric tools with flexible cords. Keep the cord away from heat, oil, sharp edges or moving parts. Damaged or twisted cords can increase the risk of electric shock.

5- When using electric tools outdoors, use extension cables suitable for outdoor use. Wires suitable for outdoor use will reduce the risk of electric shock.

6- If it is impossible to avoid operating electric tools in humid environment, power supply with residual current device (RCD) protection shall be used. The use of RCD can reduce the risk of electric shock.

7- Electric tools will produce electromagnetic fields (EMF) that are harmless to users. However, users of pacemakers and other similar medical devices should consult the manufacturer and/or doctor of their devices for advice before operating this electric tool.

■ PERSONAL SAFETY

1- Keep alert, pay attention to the operation and keep awake when operating electric tools. Do not operate electric tools when you feel tired,

or have drug, alcohol or treatment reactions. Transient negligence in the operation of electric tools can cause serious personal injury.

2- Use personal protective equipment. Always wear goggles. Protective devices, such as the use of dust masks, anti-slip safety shoes, safety helmets, hearing protection and other devices under appropriate conditions, can reduce personal injury.

3- Prevent accidental starting. Make sure the switch is in the off position before connecting the power supply and/or battery pack, picking up or handling tools. Danger can be caused by putting your fingers on the switch to handle the tool or energizing the switch when it is on.

4- Remove all adjustment keys or wrenches before the power tool is turned on. Wrenches or keys left on rotating parts of electric tools can cause personal injury.

5- Don't stretch your hands too far. Always pay attention to foothold and body balance. This can better control the electric tools in case of accidents.

6- Dress appropriately. Do not wear loose clothes or accessories. Keep your hair and clothes away from moving parts. Loose clothing, accessories or long hair may get caught in moving parts.

7- If a device is provided to connect with the chip removal and dust collection equipment, ensure that it is well connected and properly used. The use of dust collection devices can reduce the danger caused by dust.

8- Don't take it lightly because of the familiarity generated by frequent use of tools, and ignore the safety rules of tools. A careless action may cause serious injury in an instant.

9- Always wear goggles when using electric tools to avoid eye injury. Goggles must comply with ANSI Z87.7 in the United States, EN166 in Europe or AS/NZS 1336 in Australia/New Zealand. In Australia/New Zealand, the law requires wearing a mask to protect the face.

The employer is responsible for supervising the tool operators and other personnel near the work area to wear appropriate safety protection equipment.

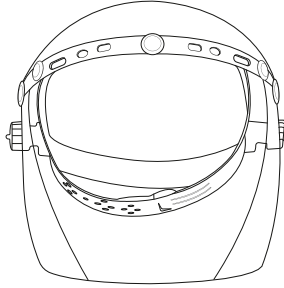

■ USE AND PRECAUTIONS OF ELECTRIC TOOLS

1- electric tools according to the purpose. Choosing the right power tools designed according to the rating will make your work more efficient and safer.

2- If the switch cannot turn on or off the power supply, the power tool cannot be used. Power tools that cannot be controlled by switches are dangerous and must be repaired.

3- Before making any adjustment, replacing accessories or storing electric tools, you must unplug the power supply and / or remove the battery pack (if detachable). This protective safety measure reduces the risk of accidental starting of the power tool.

4- Store unused electric tools outside the reach of children and do not allow people who are unfamiliar with electric tools and do not understand these instructions to operate electric tools. Power tools are dangerous in the hands of untrained users.

5- Maintain electric tools and their accessories. Check whether the moving parts are in place or stuck, check the parts for damage and other conditions affecting the operation of power tools. If damaged, repair the power tool before use. Many accidents are caused by poorly maintained power tools.

6- Keep the cutting tools sharp and clean. A well-maintained tool with a sharp cutting edge is not easy to jam and is easy to control.

7- Select the cutter heads of electric tools, accessories and tools according to the instruction manual and considering the working conditions and

operations to be carried out. The use of power tools for operations that are not compatible with their purpose can lead to dangerous situations.

8- Keep the handle and holding surface dry and clean, and do not be stained with grease. In the event of an accident, the slippery handle does not guarantee a secure grip and control of the tool.

9- When using this tool, do not wear cloth work gloves that may tangle. Personal injury may result from cloth work gloves caught in moving parts.

■ USE AND PRECAUTIONS OF ELECTRIC BATTERY TOOLS

1- Only use the charger specified by the manufacturer for charging. The charger used for one battery pack may cause fire hazard when using other battery packs.

2- Only use electric tools with special battery packs. Using other battery packs may cause injury and fire hazard.

3- When the battery pack is not in use, keep it away from other metal objects, such as paper clips, coins, keys, nails, screws or other small metal objects, to prevent one end of the battery pack from connecting with the other end. Short circuit at the end of the battery pack may cause combustion or fire.

4- Under abuse conditions, the liquid may spill from the battery pack; Avoid contact. In case of accidental contact with liquid, flush with water. If liquid in case of eye contact, you should also seek medical help. The liquid spilled from the battery may corrode or burn.

5- Do not use damaged or modified battery packs or tools. Damaged or modified battery packs may present unpredictable results, resulting in fire, explosion or injury.

6- Do not expose the battery pack to fire or high temperature. The battery pack may explode when exposed to fire or high temperature higher than 130°C.

7- Follow all charging instructions. Do not charge the battery pack or electric tools outside the temperature range specified in the manual. Incorrect charging or charging outside the specified temperature range

may damage the battery and increase the risk of ignition.

■ REPAIR

- 1- Let professional maintenance personnel use the same spare parts to repair electric tools. This will ensure the safety of the electric tools to be repaired.
- 2- Never repair a damaged battery pack. The battery pack can only be repaired by the manufacturer or its authorized service provider.
- 3- Please follow the instructions in this manual when applying lubricating oil and replacing accessories.

■ Safety warning for use of rechargeable wrenches

- 1- Please wear earmuffs.
- 2- Please carefully check the impact sleeve for wear, cracks or damage before installation.
- 3- Please hold this tool firmly.
- 4- Keep your hands away from rotating parts.
- 5- Do not touch the impact sleeve, bolt, nut or workpiece immediately after operation. They can be very hot and cause skin burns.
- 6- Please be sure to stand firm. When using tools at heights, make sure that there is no one below.
- 7- Appropriate tightening torque may vary with the type or size of bolts. Use a torque wrench to confirm the torque.

PLEASE KEEP THIS MANUAL

WARNING

Do not follow the relevant product safety rules for the sake of convenience or because you are familiar with the product (experience gained from repeated use).

Improper use or failure to follow the safety rules in the instruction manual may cause serious personal injury.

■ IMPORTANT SAFETY PRECAUTIONS FOR BATTERY PACK

- 1- Before using the battery pack, please carefully read all the instructions and (1) the battery charger, (2) the battery, and (3) the warning signs on the products using the battery.
- 2- Do not disassemble or modify the battery pack. Otherwise, it may cause fire, overheating or explosion.
- 3- If the running time of the machine becomes too short, please stop using it immediately. Otherwise, it may cause overheating, fire and even explosion.
- 4- If the electrolyte enters your eyes, rinse it with clean water and seek medical attention immediately. Otherwise, vision may be damaged.
- 5- Do not short-circuit the battery pack: (1) Do not allow any conductive material to touch the terminal. (2) Avoid placing the battery pack and other metal objects such as nails, coins, etc. in the same container. (3) Do not put the battery pack in water or expose it to rain. Short circuit of battery will generate large current, cause overheating, and may cause fire or even breakdown.
- 6- Do not store and use tools and battery packs in places where the temperature may reach or exceed 50° C (122° F).
- 7- Do not incinerate the battery pack even if it is severely damaged or completely worn. The battery pack will explode in fire.
- 8- Do not shoot nails at the battery pack, or cut, squeeze, throw, drop the battery pack, or hit the battery pack with hard objects. Otherwise, it may cause fire, overheating or explosion.
- 9- Do not use damaged batteries.
- 10- The lithium-ion battery attached to this tool must comply with the requirements of hazardous goods regulations. The third party or forwarding agent shall comply with the special requirements for packaging and marking when conducting commercial transportation. Consult professionals in the field of dangerous goods for the preparation of transportation projects. At the same time, please comply with the possibly more detailed national regulations. Please use adhesive tape to protect and not cover the contact information on the surface, and

firmly seal the battery so that it cannot be moved in the package.

11- When discarding the battery pack, remove it from the tool and dispose it in a safe place. Please follow local regulations on how to dispose of waste batteries.

12- Use the battery only for the products specified by RONIX. Installing the battery to an incompatible product will cause fire, overheating, explosion or electrolyte leakage.

13- If the tools not used for a long time, the battery must be removed from the tool.

14- During and after using the tool, the battery pack temperature may be too high to cause burns or low temperature burns. Handle the high-temperature battery pack with care.

15- Do not touch the terminal of the tool immediately after using it, otherwise it may cause burns.

16- Avoid sawdust, dust or dirt getting stuck in the terminals, holes and grooves of the battery pack. Otherwise, the performance of the tool or battery pack may deteriorate or fail.

17- Do not use the battery pack near the high-voltage power line unless the tool supports the use near the high-voltage power line. Failure to do so may result in tool or battery pack failure or malfunction.

18- Make sure the battery is away from children.

WARNING

Please use only the original battery. The use of non-original batteries or modified batteries may lead to battery explosion, resulting in fire, personal injury or damage to goods.

■ TIPS FOR MAINTAINING THE MAXIMUM BATTERY LIFE

1- Charge the battery pack in time before it is completely discharged. When the power of the tool is low, please stop the tool operation and charge the battery pack.

2- Do not recharge a fully charged battery pack. Overcharging will shorten the service life of the battery.

- 3- Please charge the battery pack at room temperature of 10 ° C - 40 ° C (50 ° F - 104 ° F). Please recharge after the hot battery pack cools down.
- 4- Remove the battery pack from the tool or charger when not in use.
- 5- If the battery is not used for a long time (more than six months), please charge it.

FUNCTIONAL DESCRIPTION

! WARNING

Before adjusting or checking the function of the tool, be sure to turn off the power of the tool and take out the battery pack.

INSTALLING OR REMOVING THE BATTERY PACK

! WARNING

Before installing or removing the battery pack, be sure to turn off the power supply of the tool

! WARNING

Please hold the tool and battery pack tightly when installing or removing the battery pack.

Otherwise, they may slip from your hands, causing damage to tools and battery packs, and even personal injury.

When removing the battery pack, press the button on the front side of the battery pack and pull the battery pack out of the tool at the same time. When installing the battery pack, align the tongue spring on the

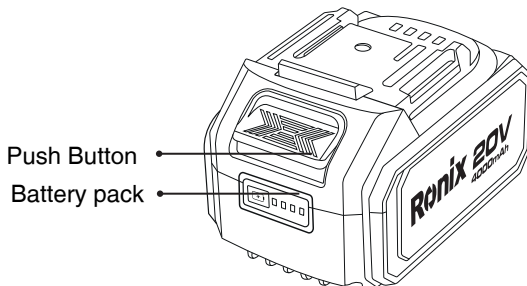

battery pack with the groove on the cover, and then push and slide it into place. Insert it fully into place until the battery pack is locked and clicks. If you can still see the red indicator on the upper side of the button after inserting it, it means that the battery pack is not fully locked.

WARNING

Be sure to fully install the battery pack until the clip is not visible. Otherwise, it may fall off accidentally from the tool and cause injury to yourself or others.

WARNING

Do not force the battery pack.

If the battery pack is difficult to insert, the insertion method may be improper.

TOOL / BATTERY PROTECTION SYSTEM

This tool is equipped with a tool/battery protection system. The system can automatically cut off the power to prolong the life of tools and batteries. During operation, if the tool or battery is under the following conditions, the tool will automatically stop running.

OVERLOAD PROTECTION

This protection function will be activated when the tool is operated in a way that causes abnormally high current. In this case, close the tool and stop the application that caused the tool overload. Then start the tool and restart.

OVERHEAT PROTECTION

When the tool overheats, the tool will automatically stop running and the indicator will flash. In this case, please wait for the tool and battery to cool before restarting the tool.

■ OVER DISCHARGE PROTECTION

This protection function will be activated when the remaining battery power becomes low. At this time, please take out the battery in the tool and charge it.

NOTE: Under different operating conditions and ambient temperatures, the power indicated by the indicator may be slightly different from the actual situation.

DISPLAYS THE REMAINING POWER OF THE BATTERY

Press the stepless speed change switch to display the remaining battery power, and the indicator will light up for several seconds.

GREEN INDICATOR

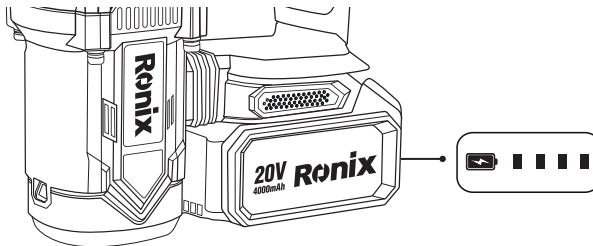

Indicator light on type	The light is on	OFF	Twinkle
Remaining Power	■ ■ ■	□	■
	■ ■ □	□	■
	■ □ □	□	■
	■ □ □	□	■
Fault	■ ■ ■	□	■
Under Voltage Protection	■ □ □	□	■

NOTE: Under different operating conditions and ambient temperatures, the power indicated by the indicator may be slightly different from the actual situation.

FAULT PROMPT

LED continuous full flash 1 time: short circuit protection.

LED continuous full flash 2 times: battery pack over-temperature protection.

LED continuous full flash 3 times: controller MOS tube over-temperature protection.

LED continuous full flash 4 times: motor blocking protection.

LED continuous full flash 5 times: overcurrent protection.

LED continuous full flash 6 times: undervoltage/short power-down protection.

LED continuous full flash 8 times: over-voltage protection.

LED continuous full flash 9 times: forward and reverse switching abnormal protection.

LED continuous full flash 10 times: anti-gyroscope dumping.

SWITCH OPERATION

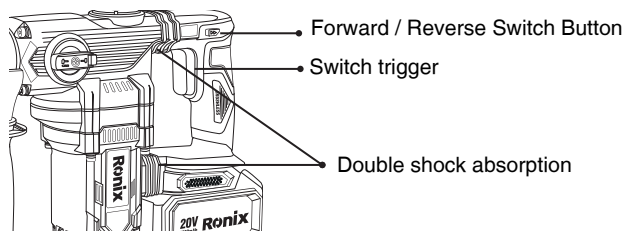

WARNING

Before inserting the battery pack into the tool, be sure to check whether the switch trigger can be pulled freely and can return to the "OFF" position when it is released.

When starting the tool, just pull the switch trigger. As the pressure on the switch trigger increases, the tool speed will increase. Release the switch trigger tool to stop.

ASSEMBLING

Be sure to turn off the tool before adjusting or checking its function and remove the battery pack.

SELECT ACTION MODE

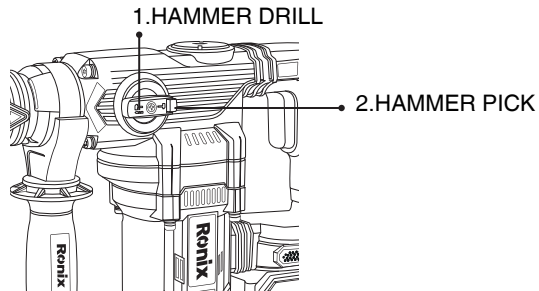

- 1- The function is used for light chiseling. In this working mode, the tool can also be used as a lever to clean the stuck drill bit.
- 2- The function machine performs vibration drilling on concrete or stone.

⚠ Warning: The machine must be shut down before the function can be selected and changed! Otherwise, the machine will be damaged and even the operator will be injured. Rotate the function selector to the desired function icon position and select the desired function.

■ SCREW

- 1- Install the correct screwdriver head.
- 2- Make sure that the function selector knob is set on the drill mode.
- 3- According to the actual operation, use the appropriate rotation speed and start to gently press the start/stop switch.

4- After gripping the machine and taking full control of the machine, increase the speed.

5- Apply appropriate pressure to prevent the screwdriver head from separating from the nut during rotation. The nut is easily damaged, making it difficult to remove or tighten.

■ DRILL HOLE

To drill a large diameter hole, it is better to drill small hole with a small bit, and then gradually expand the hole diameter to the required size. This will prevent the machine from overloading. If the drill bit is blocked, shut down the machine immediately, otherwise the machine will be damaged. The drill bit can be removed by reversing. Align the machine with the hole. Ideally, the drill should be vertically drilled into the workpiece. During drilling, if the angle changes, the drill bit may damage the hole and cause injury. When the drill is about to penetrate the workpiece, let the machine work by itself. Keep the drill sharp.

■ DRILL TIMBER

In order to achieve the best operation effect, please use fried dough twist drill or woodworking drill when drilling timber. Set the machine in drill mode.

Start drilling at a slower speed to prevent the bit from slipping from the starting point. Increase the speed as the drill bit penetrates into the material. When drilling through, place a section of backing plate at the back of the workpiece to prevent the drilled hole from exploding.

■ DRILL METAL

To achieve the best operation effect, use high-speed steel drill bit when drilling metal.

1- Set the machine in drill mode.

2- Use the center punch to mark the center of the round hole on the workpiece.

3- Apply some grease on the drill bit to prevent the drill bit from

overheating. The grease applied will prolong the life of the drill bit and improve the drilling effect.

4- Start drilling at a very slow speed to prevent the bit from slipping from the starting point.

5- Clamp the steel plate.

6- Use a wooden block to pad the steel plate to prevent the steel plate from deformation during drilling.

■ DIAMOND MATERIAL

In order to achieve the best operation effect, please use carbide drill bit when drilling on bricks, tiles, cement and other materials. At first, use the drilling mode to drill first, and once the hole is drilled, switch to the hammering mode. When drilling a hole in a tile, try it on an abandoned tile first, so as to determine the best rotational speed and the applied force.

■ PRACTICAL APPLICATION

Make sure that the electric tool has been closed, and then push the electric tool onto the screw head. The rotating drill is easy to slide off the screw head. Hold the machine tightly, place the drill bit on the object to be processed, and apply appropriate pressure to ensure the drilling function of the drill bit. Do not press the hammer and do not press the hammer from the side.

Note: Once the drill bit is found stuck in the machined part, immediately turn off the switch, stop the machine rotation, take out the drill bit, check the cause and maintain it well before continuing to work.

■ BATTERY PACK

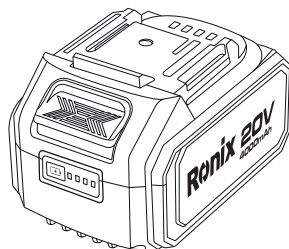

■ HOW TO USE THE BATTERY PACK CORRECTLY TO PROTECT THE BATTERY PACK

Protect the battery pack from moisture and moisture. The battery pack must be stored in an environment of 0 to 45 degrees Celsius. Do not leave the battery pack in the car in summer. The service time of the battery pack is significantly shortened after charging, which means that the battery pack has been damaged and must be replaced with a new one.

■ CONTINUOUS USE

When the machine is continuously used until the battery power is exhausted, please allow the machine to cool for 15 minutes before replacing the new battery pack.

■ OVER DISCHARGE PROTECTION

The machine is equipped with an over-discharge protection circuit. When the battery power is insufficient, the protection circuit will be opened and the machine will stop rotating.

■ DISPOSAL OF WASTE BATTERY PACKS

To protect natural resources, please properly recycle or dispose of the battery pack. The battery contains lithium battery. Please consult the relevant local authorities for information on recycling (/or) treatment. After the battery pack is discharged, remove the battery pack and wrap the terminal with strong adhesive tape to avoid short circuit and leakage. It is absolutely forbidden to try to open or take any parts or components.

■ BATTERY PACK CHARGING

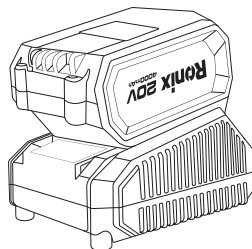

■ BATTERY CHARGING

- 1- Please charge indoors.
- 2- Only use the battery and charger matched with the electric tool.
- 3- The battery is only partially charged at the time of delivery. Before using electric tools for the first time, the battery must be fully charged to ensure the power of the battery.
- 4- The lithium battery can be charged at any time without shortening its service life. If the charging process is interrupted suddenly, the battery will not be damaged.
- 5- It takes 2.0 Ah 60 minutes, 4.0 Ah 120 minutes, 6.0 Ah 180 minutes and 8.0 Ah 240 minutes for the fully depleted battery to recharge at the temperature of 0-45°C.
- 6- NTC temperature monitoring device is installed on the battery. When the temperature level is between 5 and 40 degrees Celsius, the battery can be charged. Therefore, it can greatly prolong the service life of the battery.
- 7- Please pay attention to the regulations on the disposal of lithium batteries.

■ MEANING OF CHARGER INDICATOR

Indicator Light	State
Red light is always on	Charging
Green light is always on	Standby/charging completed



www.ronixtools.com