

# Ronix<sup>®</sup>

Premium Quality

**16V BRUSHLESS CORDLESS  
SCREWDRIVER 150N.m  
8668**

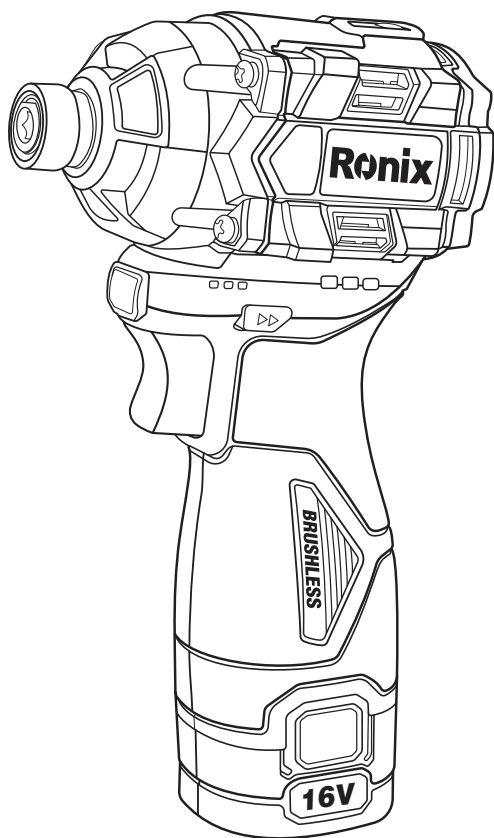

[www.ronixtools.com](http://www.ronixtools.com)



## TECHNICAL SPECIFICATION

Model	<b>8668</b>
Battery Type	Lithium-ion
Battery Capacity	16V / 2 Ah
Head Style	Hex socket
Head Size	6.35mm/1/4"
No-Load Speed	0-3200RPM
Impact Rate	0-4000BPM
Max Torque	150N·m
Body material	PA6+GF30
Dimensions	117×182×62.7mm
Weight	1.06Kg(with 1pc battery pack)
Packaging	BMC
Include	2pcs battery packs 1pc charger 3pcs Hex shank twist drill(3.2mm/4.2mm/5.2mm) 2 pcs heel block (spacer)

## PART LIST

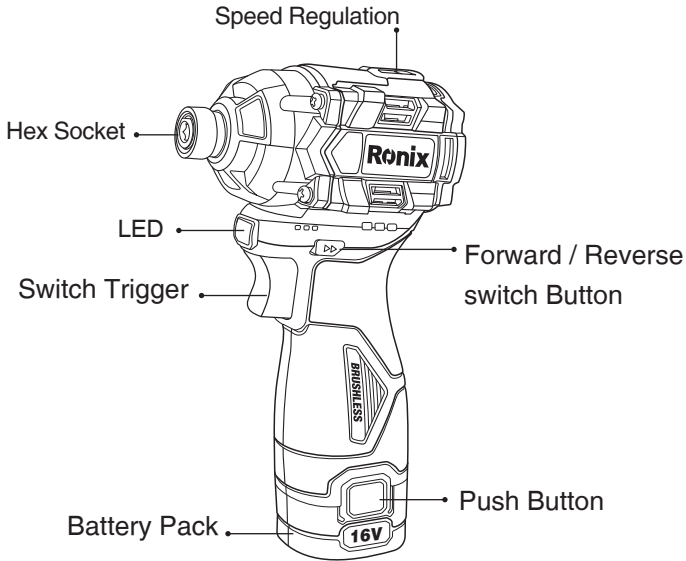

Read the instruction manual

**Purpose: This tool used to screw in and out screws, and can also drillholes in wood, metal, pottery and plastic.**

Read all safety warnings, instructions, and regulations provided with the electric tool. Failure to follow the instructions listed below may result in electric shock, fire and/or serious injury.

Keep all warnings and instructions for reference. The term "electric tool" in the warning refers to a commercially available (wired) electric tool or a battery-powered (wireless) electric tool.

## SAFETY OF WORKPLACE

1- Keep the workplace clean and bright. Disordered and dark places can cause accidents.

2- Do not operate electric tools in explosive environment, such as flammable liquid, gas or dust. Sparks generated by electric tools can ignite

dust or gas.

3- Keep away from children and bystanders when operating electric tools. Lack of concentration will make you lose control of tools.

## ■ ELECTRICAL SAFETY

1- The plug of electric tool must match the socket. Never modify the plug in any way. Electric tools that need to be grounded cannot use any conversion plug. Unmodified plugs and matching sockets will reduce the risk of electric shock.

2- Avoid human contact with grounding surfaces, such as pipes, cooling fins and refrigerators. If you touch the ground surface, you will increase the risk of electric shock.

3- Do not expose electric tools to rain or damp environment. Water entering electric tools will increase the risk of electric shock.

4- Do not abuse the cord. Never carry, pull or unplug electric tools with flexible cords. Keep the cord away from heat, oil, sharp edges or moving parts. Damaged or twisted cords can increase the risk of electric shock.

5- When using electric tools outdoors, use extension cables suitable for outdoor use. Wires suitable for outdoor use will reduce the risk of electric shock.

6- If it is impossible to avoid operating electric tools in humid environment, power supply with residual current device (RCD) protection shall be used. The use of RCD can reduce the risk of electric shock.

7- Electric tools will produce electromagnetic fields (EMF) that are harmless to users. However, users of pacemakers and other similar medical devices should consult the manufacturer and/or doctor of their devices for advice before operating this electric tool.

## ■ PERSONAL SAFETY

1- Keep alert, pay attention to the operation and keep awake when operating electric tools. Do not operate electric tools when you feel tired, or have drug, alcohol or treatment reactions. Transient negligence in the operation of electric tools can cause serious personal injury.

2- Use personal protective equipment. Always wear goggles. Protective devices, such as the use of dust masks, anti-slip safety shoes, safety helmets, hearing protection and other devices under appropriate conditions, can reduce personal injury.

3- Prevent accidental starting. Make sure the switch is in the off position before connecting the power supply and/or battery pack, picking up or handling tools. Danger can be caused by putting your fingers on the switch to handle the tool or energizing the switch when it is on.

4- Remove all adjustment keys or wrenches before the power tool is turned on. Wrenches or keys left on rotating parts of electric tools can cause personal injury.

5- Don't stretch your hands too far. Always pay attention to foothold and body balance. This can better control the electric tools in case of accidents.

6- Dress appropriately. Do not wear loose clothes or accessories. Keep your hair and clothes away from moving parts. Loose clothing, accessories or long hair may get caught in moving parts.

7- If a device is provided to connect with the chip removal and dust collection equipment, ensure that it is well connected and properly used. The use of dust collection devices can reduce the danger caused by dust.

8- Don't take it lightly because of the familiarity generated by frequent use of tools, and ignore the safety rules of tools. A careless action may cause serious injury in an instant.

9- Always wear goggles when using electric tools to avoid eye injury. Goggles must comply with ANSI Z87.7 in the United States, EN166 in Europe or AS/NZS 1336 in Australia/New Zealand. In Australia/New Zealand, the law requires wearing a mask to protect the face.

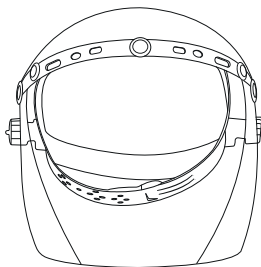

The employer is responsible for supervising the tool operators and other personnel near the work area to wear appropriate safety protection equipment.

## **■ USE AND PRECAUTIONS OF ELECTRIC TOOLS**

1- electric tools according to the purpose. Choosing the right power tools designed according to the rating will make your work more efficient and safer.

2- If the switch cannot turn on or off the power supply, the power tool cannot be used. Power tools that cannot be controlled by switches are dangerous and must be repaired.

3- Before making any adjustment, replacing accessories or storing electric tools, you must unplug the power supply and / or remove the battery pack (if detachable) . This protective safety measure reduces the risk of accidental starting of the power tool.

4- Store unused electric tools outside the reach of children and do not allow people who are unfamiliar with electric tools and do not understand these instructions to operate electric tools. Power tools are dangerous in the hands of untrained users.

5- Maintain electric tools and their accessories. Check whether the moving parts are in place or stuck, check the parts for damage and other conditions affecting the operation of power tools. If damaged, repair the power tool before use. Many accidents are caused by poorly maintained power tools.

6- Keep the cutting tools sharp and clean. A well-maintained tool with a sharp cutting edge is not easy to jam and is easy to control.

7- Select the cutter heads of electric tools, accessories and tools according to the instruction manual and considering the working conditions and operations to be carried out. The use of power tools for operations that are not compatible with their purpose can lead to dangerous situations.

8- Keep the handle and holding surface dry and clean, and do not be stained with grease. In the event of an accident, the slippery handle does not guarantee a secure grip and control of the tool.

9- When using this tool, do not wear cloth work gloves that may tangle.

Personal injury may result from cloth work gloves caught in moving parts.

## ■ USE AND PRECAUTIONS OF ELECTRIC BATTERY TOOLS

1- Only use the charger specified by the manufacturer for charging. The charger used for one battery pack may cause fire hazard when using other battery packs.

2- Only use electric tools with special battery packs. Using other battery packs may cause injury and fire hazard.

3- When the battery pack is not in use, keep it away from other metal objects, such as paper clips, coins, keys, nails, screws or other small metal objects, to prevent one end of the battery pack from connecting with the other end. Short circuit at the end of the battery pack may cause combustion or fire.

4- Under abuse conditions, the liquid may spill from the battery pack; Avoid contact. In case of accidental contact with liquid, flush with water. If liquid in case of eye contact, you should also seek medical help. The liquid spilled from the battery may corrode or burn.

5- Do not use damaged or modified battery packs or tools. Damaged or modified battery packs may present unpredictable results, resulting in fire, explosion or injury.

6- Do not expose the battery pack to fire or high temperature. The battery pack may explode when exposed to fire or high temperature higher than 130°C.

7- Follow all charging instructions. Do not charge the battery pack or electric tools outside the temperature range specified in the manual. Incorrect charging or charging outside the specified temperature range may damage the battery and increase the risk of ignition.

## ■ REPAIR

1- Let professional maintenance personnel use the same spare parts to repair electric tools. This will ensure the safety of the electric tools to be repaired.

2- Never repair a damaged battery pack. The battery pack can only be



repaired by the manufacturer or its authorized service provider.

3- Please follow the instructions in this manual when applying lubricating oil and replacing accessories.

## **SAFETY WARNING FOR USE OF RECHARGEABLE WRENCHES**

1- Please wear earmuffs.

2- Please carefully check the impact sleeve for wear, cracks or damage before installation.

3- Please hold this tool firmly.

4- Keep your hands away from rotating parts.

5- Do not touch the impact sleeve, bolt, nut or workpiece immediately after operation. They can be very hot and cause skin burns.

6- Please be sure to stand firm. When using tools at heights, make sure that there is no one below.

7- Appropriate tightening torque may vary with the type or size of bolts. Use a torque wrench to confirm the torque.

## **PLEASE KEEP THIS MANUAL**

### **WARNING**

Do not follow the relevant product safety rules for the sake of convenience or because you are familiar with the product (experience gained from repeated use) .

Improper use or failure to follow the safety rules in the instruction manual may cause serious personal injury.

### **■ IMPORTANT SAFETY PRECAUTIONS FOR BATTERY PACK**

1- Before using the battery pack, please carefully read all the instructions and (1- the battery charger, (2- the battery, and (3- the warning signs on the products using the battery.

2- Do not disassemble or modify the battery pack. Otherwise, it may cause

fire, overheating or explosion.

3- If the running time of the machine becomes too short, please stop using it immediately. Otherwise, it may cause overheating, fire and even explosion.

4- If the electrolyte enters your eyes, rinse it with clean water and seek medical attention immediately. Otherwise, vision may be damaged.

5- Do not short-circuit the battery pack:

1- Do not allow any conductive material to touch the terminal.

2- Avoid placing the battery pack and other metal objects such as nails, coins, etc. in the same container.

3- Do not put the battery pack in water or expose it to rain. Short circuit of battery will generate large current, cause overheating, and may cause fire or even breakdown.

6- Do not store and use tools and battery packs in places where the temperature may reach or exceed 50° C (122° F) .

7- Do not incinerate the battery pack even if it is severely damaged or completely worn. The battery pack will explode in fire.

8- Do not shoot nails at the battery pack, or cut, squeeze, throw, drop the battery pack, or hit the battery pack with hard objects. Otherwise, it may cause fire, overheating or explosion.

9- Do not use damaged batteries.

10- The lithium-ion battery attached to this tool must comply with the requirements of hazardous goods regulations. The third party or forwarding agent shall comply with the special requirements for packaging and marking when conducting commercial transportation. Consult professionals in the field of dangerous goods for the preparation of transportation projects. At the same time, please comply with the possibly more detailed national regulations. Please use adhesive tape to protect and not cover the contact information on the surface, and firmly seal the battery so that it cannot be moved in the package.

11- When discarding the battery pack, remove it from the tool and dispose it in a safe place. Please follow local regulations on how to dispose of waste batteries.

12- Use the battery only for the products specified by RONIX. Installing the

battery to an incompatible product will cause fire, overheating, explosion or electrolyte leakage.

13- If the tools not used for a long time, the battery must be removed from the tool.

14- During and after using the tool, the battery pack temperature may be too high to cause burns or low temperature burns. Handle the high-temperature battery pack with care.

15- Do not touch the terminal of the tool immediately after using it, otherwise it may cause burns.

16- Avoid sawdust, dust or dirt getting stuck in the terminals, holes and grooves of the battery pack. Otherwise, the performance of the tool or battery pack may deteriorate or fail.

17- Do not use the battery pack near the high-voltage power line unless the tool supports the use near the high-voltage power line. Failure to do so may result in tool or battery pack failure or malfunction.

18- Make sure the battery is away from children.

## **WARNING**

Please use only the original battery

The use of non-original batteries or modified batteries may lead to battery explosion, resulting in fire, personal injury or damage to goods.

## **■ TIPS FOR MAINTAINING THE MAXIMUM BATTERY LIFE**

1- Charge the battery pack in time before it is completely discharged. When the power of the tool is low, please stop the tool operation and charge the battery pack.

2- Do not recharge a fully charged battery pack. Overcharging will shorten the service life of the battery.

3- Please charge the battery pack at room temperature of 10 ° C - 40 ° C (50 ° F - 104 ° F) . Please recharge after the hot battery pack cools down.

4- Remove the battery pack from the tool or charger when not in use.

5- If the battery is not used for a long time (more than six months) , please charge it.

## FUNCTION DESCRIPTION

### **⚠ WARNING**

Before adjusting or checking the function of the tool, be sure to turn off the power of the tool and take out the battery pack.

## INSTALLING OR REMOVING THE BATTERY PACK

### **⚠ WARNING**

Before installing or removing the battery pack, be sure to turn off the power supply of the tool.

### **⚠ WARNING**

Please hold the tool and battery pack tightly when installing or removing the battery pack.

Otherwise, they may slip from your hands, causing damage to tools and battery packs, and even personal injury.

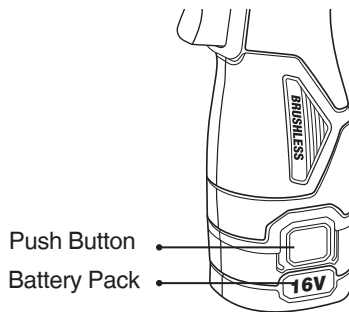

When removing the battery pack, press the button on the front side of the battery pack and pull the battery pack out of the tool at the same time. When installing the battery pack, align the tongue spring on the battery pack with the groove on the cover, and then push and slide it into place. Insert it fully into place until the battery pack is locked and clicks. If you can still see the red indicator on the upper side of the button after inserting it, it

means that the battery pack is not fully locked.

### **WARNING**

Be sure to fully install the battery pack until the clip is not visible. Otherwise, it may fall off accidentally from the tool and cause injury to yourself or others.

### **WARNING**

Do not force the battery pack.

If the battery pack is difficult to insert, the insertion method may be improper.

## **■ TOOL / BATTERY PROTECTION SYSTEM**

This tool is equipped with a tool/battery protection system. The system can automatically cut off the power to prolong the life of tools and batteries. During operation, if the tool or battery is under the following conditions, the tool will automatically stop running.

### **■ OVERLOAD PROTECTION**

This protection function will be activated when the tool is operated in a way that causes abnormally high current. In this case, close the tool and stop the application that caused the tool overload. Then start the tool and restart.

### **■ OVERHEAT PROTECTION**

When the tool overheats, the tool will automatically stop running and the indicator will flash. In this case, please wait for the tool and battery to cool before restarting the tool.

### **■ OVER DISCHARGE PROTECTION**

This protection function will be activated when the remaining battery power becomes low. At this time, please take out the battery in the tool and charge it.

**■ DISPLAYS THE REMAINING POWER OF THE BATTERY**

Press the stepless speed change switch to display the remaining battery power, and the indicator will light up for several seconds.

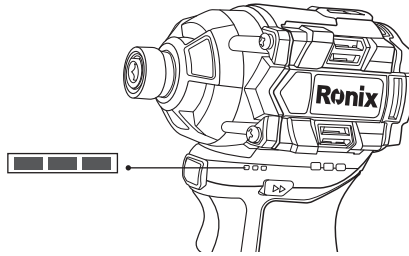

**GREEN INDICATOR**

Indicator Light On Type	The light is on ■	OFF □	Twinkle ▽
Remaining Power	■ ■ ■		
	■ ■ □		
	■ □ □		
Fault	▽ ▽ ▽		
Under Voltage Protection			▽

**⚠ NOTE:**

Under different operating conditions and ambient temperatures, the power indicated by the indicator may be slightly different from the actual situation.

**■ FAULT PROMPT**

LED flash: undervoltage protection

LED continuous full flash once: short circuit protection.

LED full flash for 2 consecutive times: battery pack over-temperature protection.

LED flashes three times continuously: controller MOS tube over-temperature protection.

LED flashes four times continuously: motor locked-rotor protection LED flashes continuously for 5 times: overcurrent protection

LED continuously flashes for 6 times: protection against sudden power failure.

LED full flash for 8 consecutive times: overvoltage protection

LED flashes for 9 consecutive times: forward and reverse switching abnormal protection

## SWITCH OPERATION

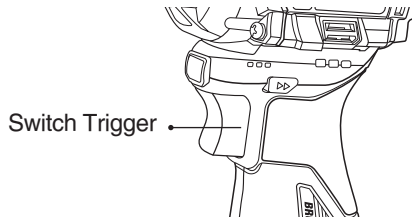

### **⚠ WARNING!**

Before inserting the battery pack into the tool, be sure to check whether the switch trigger can be pulled freely and can return to the "OFF" position when it is released.

when starting the tool, just Push the switch trigger. As the pressure on the switch trigger increases, the tool speed will increase. Release the switch trigger tool to stop.

## OPERATION OF THE REVERSE SWITCH

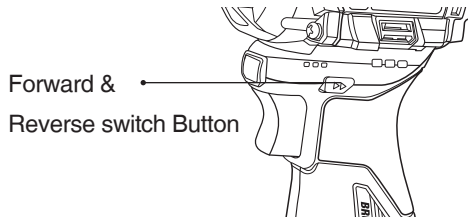

### **⚠ WARNING!**

Be sure to confirm the rotation direction of the tool before operation.

#### Warning

The reverse switch can only be used when the tool has completely stopped rotating. Changing the direction of rotation before the tool stops may damage the tool.

### **⚠ WARNING!**

When the tool is not used, make sure that the reverse switch handle is in the neutral position.

This tool is equipped with a reverse switch to change the direction of rotation. Press the reverse switch button from the front to rotate clockwise; Press from the rear to rotate counterclockwise. When the reverse switch handle is in the neutral position, the switch trigger cannot be pulled.

### **⚠ WARNING!**

Do not look directly at the light or light source

## 3 SPEED REGULATION

3 speed adjustment is simple and convenient, accurately outputting different speeds.



Gear position	No-load Speed (RPM)	Impact Rate (BPM)	Max Torque (N. m)
3rd gear	3200	3800	150
2nd gear	2400	3300	110
1st gear	1200	1500	50

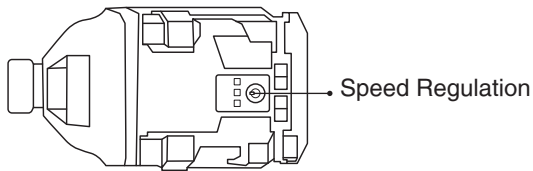

## BATTERY PACK

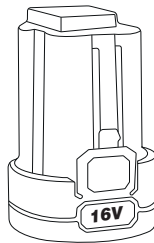

### ■ HOW TO USE THE BATTERY PACK CORRECTLY TO PROTECT THE BATTERY PACK

Protect the battery pack from moisture and moisture. The battery pack must be stored in an environment of 0 to 45 degrees Celsius. Do not leave the battery pack in the car in summer. The service time of the battery pack is significantly shortened after charging, which means that the battery pack has been damaged and must be replaced with a new one.

### ■ CONTINUOUS USE

When the machine is continuously used until the battery power is exhausted, please allow the machine to cool for 15 minutes before

replacing the new battery pack.

## ■ OVER DISCHARGE PROTECTION

The machine is equipped with an over-discharge protection circuit. When the battery power is insufficient, the protection circuit will be opened and the machine will stop rotating.

## ■ DISPOSAL OF WASTE BATTERY PACKS

To protect natural resources, please properly recycle or dispose of the battery pack. The battery contains lithium battery. Please consult the relevant local authorities for information on recycling or treatment. After the battery pack is discharged, remove the battery pack and wrap the terminal with strong adhesive tape to avoid short circuit and leakage. It is absolutely forbidden to try to open or take any parts or components.

## BATTERY PACK CHARGING

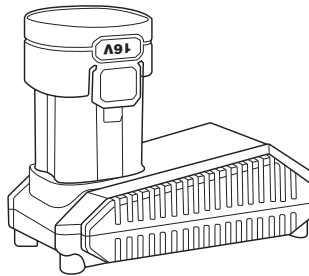

## ■ BATTERY CHARGING

Please charge indoors.

Only use the battery and charger matched with the electric tool.

The battery is only partially charged at the time of delivery. Before using electric tools for the first time, the battery must be fully charged to ensure the power of the battery.

The lithium battery can be charged at any time without shortening its

service life. If the charging process is interrupted suddenly, the battery will not be damaged.

It takes 2.0Ah 60 minutes, 4.0Ah 20 minutes, 6.0Ah 180 minutes and 8.0Ah 240 minutes for the fully depleted battery to recharge at the temperature of 0-45 °c.

NTC temperature monitoring device is installed on the battery. When the temperature level is between 5 and 40 degrees Celsius, the battery can be charged. Therefore, it can greatly prolong the service life of the battery. Please pay attention to the regulations on the disposal of lithium batteries.

## MEANING OF CHARGER INDICATOR

Indicator Light	State
The red light is always on	Charging
The green light is always on	Standby/charging completed

Part name	Hazardous Substances					
	Lead (Pb)	Mercury (Hg)	Cadmium (Cd)	Hexavalent chromium (Cr (VI))	Polybrominated biphenyls (Pb)	Polybrominated diphenyl ethers (Pb)
Enclosure	0	0	0	0	0	0
Switch	0	0	0	0	0	0
Charger	X	0	X	0	0	0
Battery	X	0	0	0	0	0
Electric Machinery	X	0	0	0	0	0
Circuit board	X	0	0	0	0	0
Copper insert	X	0	0	0	0	0
Working head	0	0	0	0	0	0
Working head clamping or fixing device	0	0	0	0	0	0
Other parts	0	0	0	0	0	0

O: It means that the content of the hazardous substance in all homogeneous materials of the component is below the limit specified in GB/T26572. 7 O: It means that the content of the hazardous substance in at least one homogeneous material of the component exceeds the limit specified in GB/T26572. Some hazardous substances listed above in the products exceed the limit requirements due to production process and technology, but are all listed in the EU exemption for hazardous substances control. Please rest assured to use them within the environmental protection service life.









[www.ronixtools.com](http://www.ronixtools.com)