

Ronix[®]

Premium Quality

KOMPAKTER AKKU-STAUBSAUGER 8640

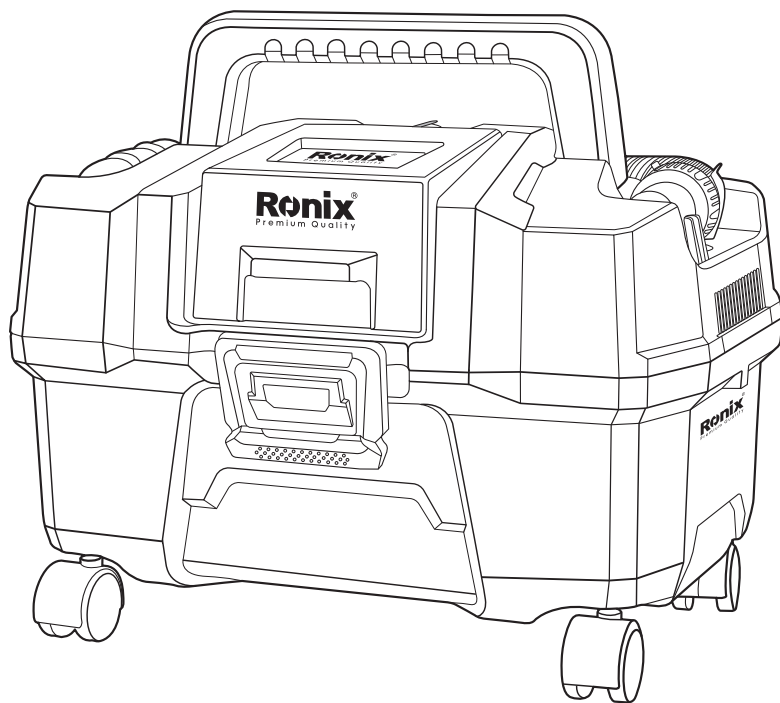

www.ronixtools.com



TECHNISCHE SPEZIFIKATIONEN

Modell	8640
Voltzahl	20V DC
Tankkapazität	15 L
Motorleistung	150W
Vakuumdruck	>10KPA
Luftstromdauer	20L/S
Laufzeit	15min
Akkutyp	Lithium ion
Geräuschpegel	75db
Gewicht	3.57Kg
Enthält	Kunststoffschlauch, waschbarer HEPA-Filter, Schwammfilter, Dreiecksbürste, Fugendüse

WERKZEUGTEILE

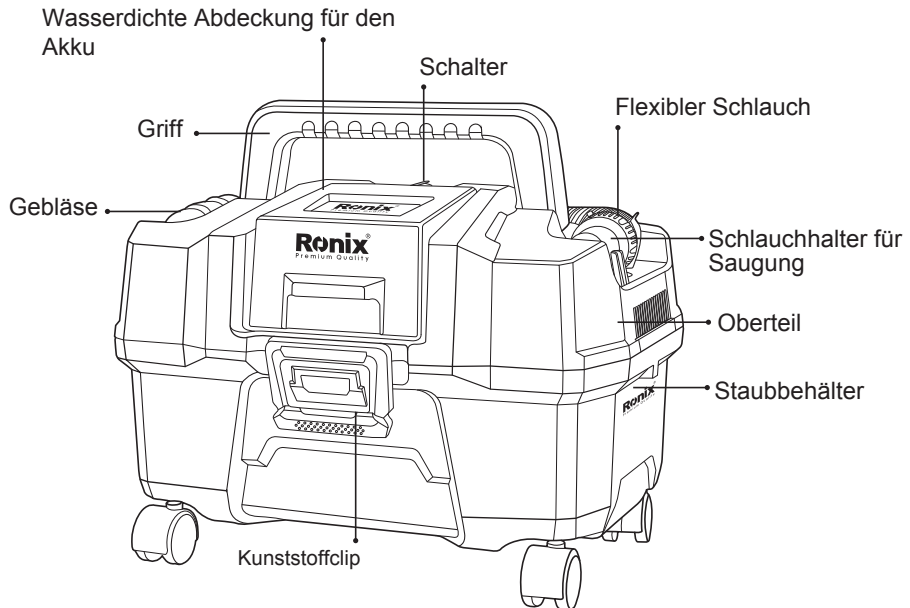

Dreiecksbürste

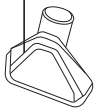

Fugendüse

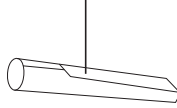

HEPA-Filter

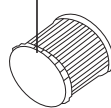

Schwammfilter



! FUGENDÜSE!

Vor der Inbetriebnahme lesen und verstehen Sie bitte sorgfältig dieses Handbuch, da das Nichtbefolgen aller unten aufgeführten Anweisungen zu einem elektrischen Schlag, Feuer und/oder schweren persönlichen Verletzungen führen kann.

! ACHTUNG!

Nur die Ronix-Akkukartuschen und Ladegeräte werden für dieses Gerät empfohlen. Die Verwendung anderer Akkukartuschen und Ladegeräte

kann zu Ausfällen und Verletzungen führen.

SICHERHEITSANWEISUNGEN

- Vor der Inbetriebnahme dieses Geräts gehen Sie bitte die Einzelheiten dieses Artikels durch, einschließlich der Batterie, des Ladegeräts und des Zubehörs. Stellen Sie sicher, dass alles in der folgenden Zubehörliste auf SEITE 3 enthalten und unbeschädigt ist.
- Dieses Gerät ist nicht für die Verwendung durch Personen (einschließlich Kinder) mit eingeschränkten physischen, sensorischen oder geistigen Fähigkeiten oder mangelnder Erfahrung und Kenntnis vorgesehen, es sei denn, sie wurden von einer für ihre Sicherheit verantwortlichen Person beaufsichtigt oder in der Verwendung des Geräts unterwiesen.
- Halten Sie alle enthaltenen Gegenstände von Kindern unter 18 Jahren fern.
- Halten Sie alle enthaltenen Gegenstände von Kindern unter 18 Jahren fern.
- Berühren Sie dieses Gerät nicht mit nassen Händen, um einen elektrischen Schlag zu vermeiden.
- Stellen Sie sicher, dass der Batterieschacht, die Akkukartusche und das Ladegerät immer trocken sind, Um einen elektrischen Schlag zu vermeiden, laden Sie die Akkukartusche nicht an einem feuchten oder nassen Ort. Verwenden, lagern oder laden Sie sie nicht an Orten, an denen die Temperatur weniger als 10°C oder mehr als 38°C beträgt. Lagern Sie sie nicht im Freien oder in Fahrzeugen. Entfernen Sie die Batterie, wenn der Staubsauger nicht in Gebrauch ist und vor Wartungsarbeiten.
- Wenn der Akkupack nicht in Gebrauch ist, halten Sie ihn fern von anderen Metallgegenständen wie Büroklammern, Münzen, Schlüsseln, Nägeln, Schrauben oder anderen kleinen Metallgegenständen, die eine Verbindung von einem Terminal zum anderen herstellen können. Das Kurzschließen der Batteriepole kann Funken, Verbrennungen oder ein Feuer verursachen.
- Verwenden Sie keine beschädigte oder modifizierte Akkukartusche.

- Kippen Sie dieses Gerät nicht um, da Staub und Flüssigkeit durch den Lufteinlass in die innere Struktur gelangen können.
- Alle defekten Teile sollten von Technikern, die von Ihren lokalen Geschäften für diese Marke ernannt wurden, modifiziert oder repariert werden.
- Halten Sie Haare, lockere Kleidung, Finger und alle Körperteile von Öffnungen und beweglichen Teilen fern.
- Verwenden Sie das Gerät nicht, um heißes Wasser/Flüssigkeiten, brennbare Gegenstände oder brennbare Flüssigkeiten) z.B. Benzin, heiße Asche, Zigaretten, Streichhölzer, explosive Materialien oder alles Brennende (aufzunehmen oder in Bereichen zu verwenden, in denen solche Substanzen und Gegenstände vorhanden sein können.
- Das Gerät unterstützt nicht das Arbeiten während des Ladens.
- Achten Sie auf die maximale Reichweite, die der flexible Schlauch erreichen kann. Bewahren Sie jederzeit einen sicheren Stand und Gleichgewicht.
- Saugen Sie niemals trockenen Staub und Müll ohne eingesetzten HEPA-Filter auf. - Denken Sie daran, den Tank, den Filter, den flexiblen Schlauch und das Zubehör nach Gebrauch zu reinigen.
- Wenn das Gerät nicht funktioniert oder Sie technische Probleme haben, kontaktieren Sie bitte das Ronix-Servicezentrum.

Ronix[®]

Premium Quality

COMPACT CORDLESS VACUUM CLEANER 8640

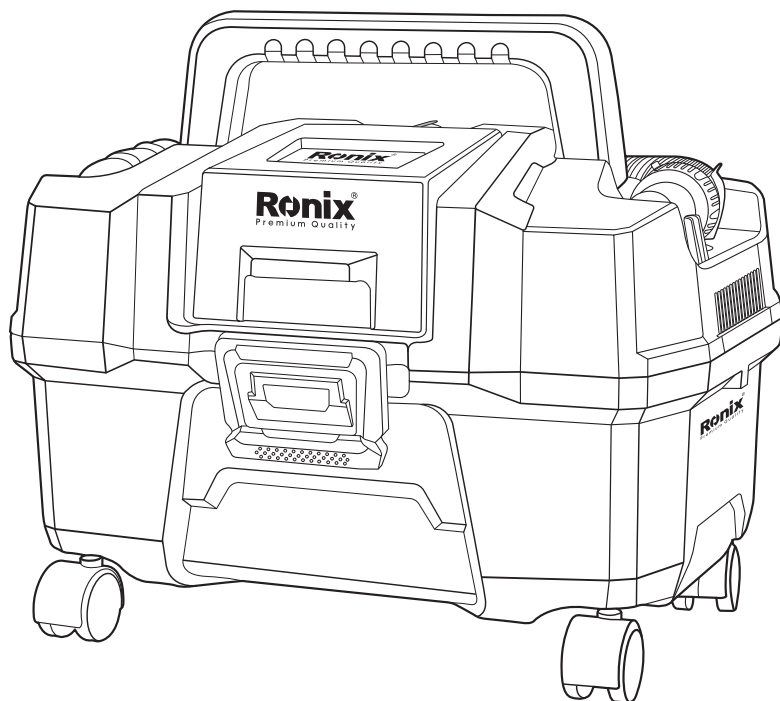

TECHNICAL SPECIFICATIONS

Model	8640
Voltage	20V DC
Tank Capacity	15 L
Motor Power	150W
Vacuum Pressure	>10KPA
Airflow Rate	20L/S
Runtime	15mins
Battery Type	lithium-ion
Noise Level	75db
Weight	3.57Kg
Includes	Plastic Hose, Washable HEPA Filter, Sponge Filter, Triangle Brush, Crevice Nozzle

PART LIST

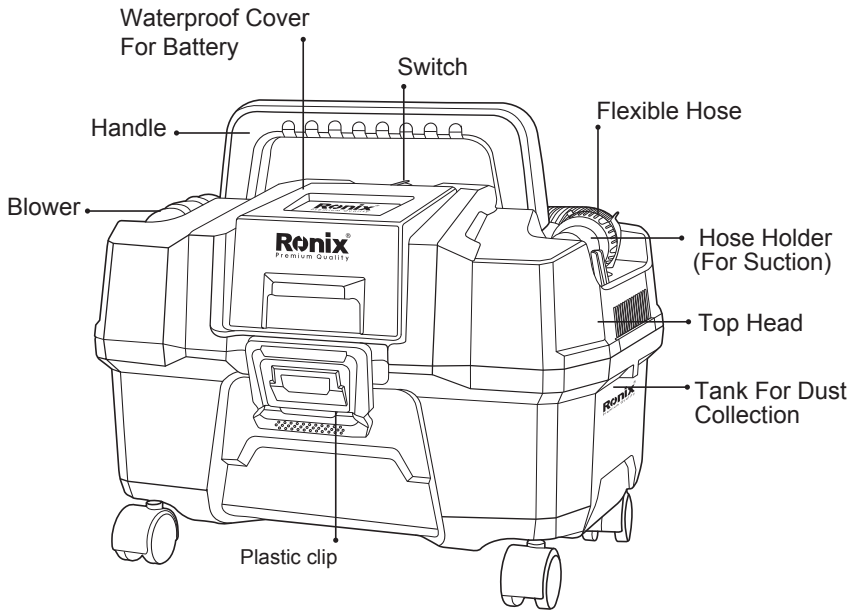

Triangular Brush

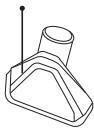

Crevice Nozzle

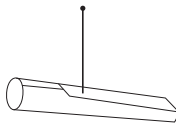

HEPA Filter

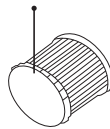

Sponge Filter



⚠ ATTENTION!

Before operating, please read and understand this manual carefully, as failure to follow all instructions listed below, may result in electric shock, fire and/or serious personal injury.

⚠ ATTENTION!

Only the Ronix batteries cartridges and chargers are recommended for this item.

Usage of any other batteries cartridges and chargers may cause breakdown and injury.

SAFETY INSTRUCTIONS

- Before operating this appliance, please go through the details of this item, including the battery, charger, and accessories. Make sure everything in the following accessory list (PAGE 3) is contained and unbroken.
- This appliance is not intended for use by persons (including children) with reduced physical, sensory or mental capabilities or lack of experience and knowledge, unless they have been given supervision or instruction concerning the use of the appliance by a person responsible for their safety.
- Keep all the items included away from children under 18 years old.
- Do not handle this appliance with wet hands, in case of any electrical shock.
- Make sure the battery slot, battery cartridge, and charger are always dry, in case of any electrical shock.
- Do not charge the battery cartridge in a damp or wet location. Do not use, store, or charge it in locations where the temperature is less than 50°F or more than 100°F. Do not store it outside or in vehicles.
- Remove the battery when the vacuum is not in use and before servicing.
- When the battery pack is not in use, keep it away from other metal objects like paper clips, coins, keys, nails, screws, or other small metal objects that can make a connection from one terminal to another. Shorting the battery terminals together may cause sparks, burns, or a fire.
- Do not use a battery cartridge which is damaged or modified.
- Do not overturn this appliance, as dust and liquid may enter the inner structure through the air inlet.
- Any broken parts should be modified or repaired by technicians appointed by your local stores for this brand.
- Keep hair, loose clothing, fingers, and all parts of the body away from openings and moving parts.
- Do not use the appliance to pick up hot water/liquids, flammable items or combustible liquids (i.e. petrol, hot ashes cigarettes, matches, explosive materials or anything burning) or use in areas where such substances and items may be present.

- The appliance doesn't support working while charging.
- Pay attention to the maximum distance which the flexible hose can reach. Keep proper footing and balance at all times.
- Never vacuum dry dust and trash without the HEPA filter fitted.
- Remember to clean the tank, the filter, the flexible hose, and accessories after usage.
- If the appliance doesn't work, or if you are facing any technical problems, please contact the Ronix service center.

OPERATION

CONNECTION OF FLEXIBLE HOSE AND ACCESSORIES

BEFORE OPERATION, THE APPLIANCE, THE FLEXIBLE HOSE AND ACCESSORIES SHOULD ALWAYS BE WELL CONNECTED.

FOR SUCTION

- Pull the hose holder in the right direction.
- Plug the connector of the hose into the holder.
- Turn the connector clockwise for locking.

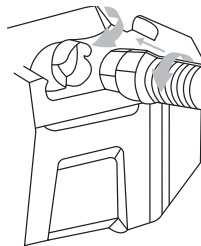

- Connect the triangular brush/crevice nozzle with the flexible hose for usage in different cases.

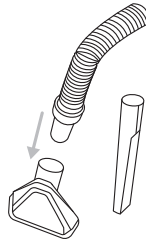

■ BLOWER

- Plug the connector of the hose into the blower.
- Turn the connector clockwise for locking.

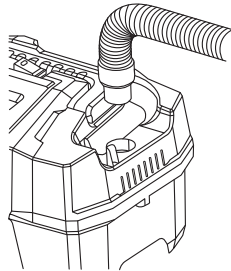

- Connect the crevice nozzle with the flexible hose for stronger airflow.

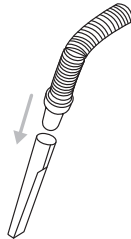

POWER ON

- Press the button on the battery cartridge, and plug it into the battery slot.
- Keep the battery cover closed.

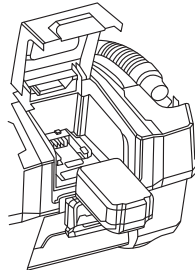

- Turn the switch to ' I ' to start the appliance.
- Turn the switch to ' 0 ' to stop the appliance.
- The light of the switch is on with a normal power supply.

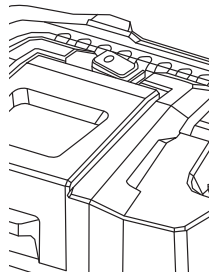

DRY VACUUMING

Please only vacuum debris in the proper size to fit through the flexible hose and accessories.

- Make sure that the flexible hose and accessories are connected, and the HEPA filter is installed properly, in case of leakage.

Do not vacuum the following:

- Flammable liquid (kerosene, gasoline, solvents such as benzene, thinner, etc.)
- Hot substances that are burning or smoking (cigarettes, matches, incense sticks, candles, hot ashes), sparks, and metal dust generated by cutting or grinding metal, etc.
- Flammable material (toner, paint, spray, etc.)
- Foam like carpet cleaning agent, etc. (they may cause explosion or fire)

- Explosive or pyrophoric substances (nitroglycerin, aluminum, magnesium, titanium, zinc, red phosphorus, yellow phosphorus, celluloid, etc., and their dust, gas, or steam).
- Sharp objects (glass, cutlery, wood splinter, metal, stone, nail, razor, push pin, etc.)
- powder (metal or carbon powder)
- Dehumidifier
- A large amount of powder (flour, fire extinguisher powder, etc.)
- Substances that cause toxic symptoms
- Aggressive chemicals (acid, leach, etc.)
- Liquid or damp garbage, including vomit and excreta
- Asbestos
- Pesticides
- When vacuuming fine debris in a case with low humidity, there might be static shock on the surface of the appliance.
- Wear insulating gloves, or spray water mist around to increase the humidity.

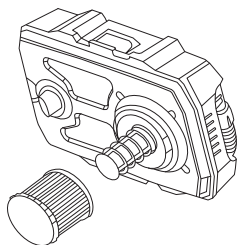

- Push the HEPA filter onto the filter seat.
- Make sure the joints on the filter are directed to the slots on the filter seat.
- Turn the HEPA filter clockwise for locking.
- Fit the head of the appliance on the tank properly.
- Lock 2 clips.

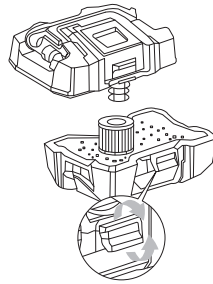

WET VACUUMING

Be aware that the cover for the battery cartridge should always be closed, otherwise, any liquid permeating the battery cartridge may cause danger.

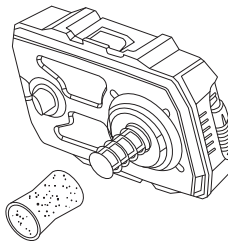

- Cover the sponge filter around the valve.
- Fit the head of the appliance on the tank properly.
- Lock 2 clips.

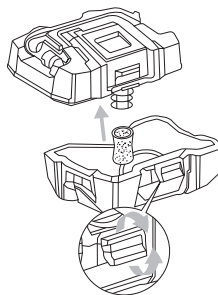

MAINTANENCE

- Make sure the appliance is switched off and the battery cartridge is removed when the appliance is not in operation.
- Keep the appliance and accessories dry when they are not in operation.

■ CLEANING OF TANK

- Empty the tank by turning it over, and shaking it.
- Wipe the tank inside with a duster cloth/paper.

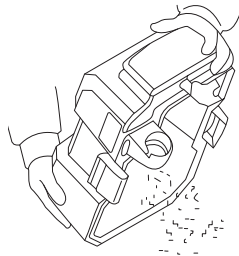

CLEANING OF FILTERS

SPONGE FILTER

- Pull the sponge filter off from the water valve.

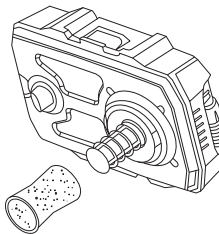

- Wash the sponge filter with water under 40°C gently.
- Dry it for 24 hours.

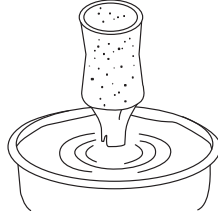

HEPA FILTER

- Turn the HEPA filter anticlockwise for unlocking it from the filter seat.
- Pull it off from the water valve.

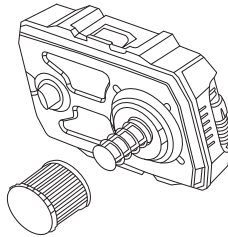

- Clean the surface of the HEPA filter with a brush.
- Wash it with water under 40°C gently.
- Dry it for 24 hours.

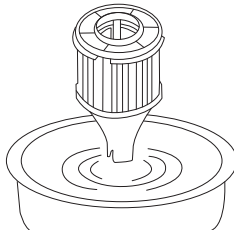

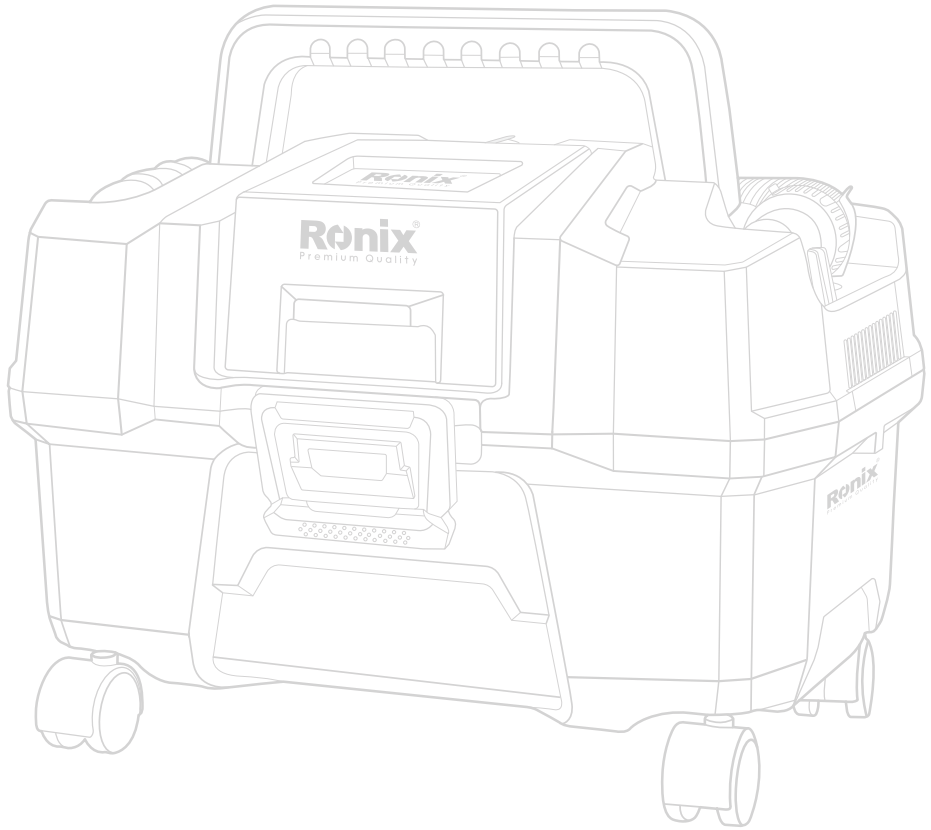





www.ronixtools.com