

Ronix[®]

Premium Quality

CORDLESS RATCHET WRENCH 20V 8625

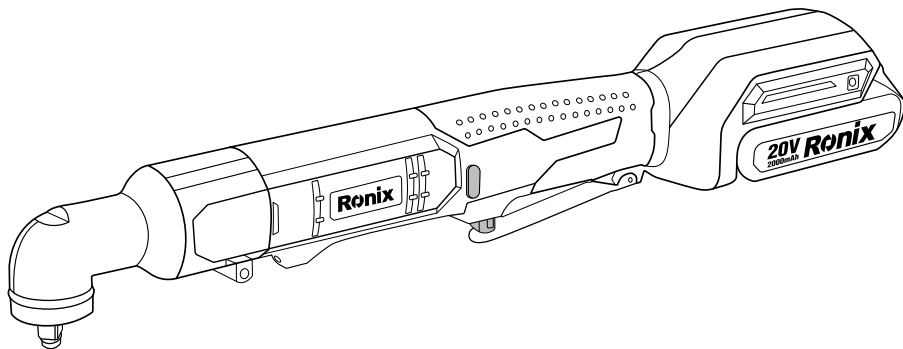

SPECIFICATIONS

Model	8625
Head Style	Square
Material	Aluminum & Plastic
Dimensions	(3/8")9.5mm
Battery Chemistry	Lithium
Battery Voltage	20V
Battery Capacity	2.0Ah
No-Load Speed	0-2000RPM
Max. Torque	80N.m
Total Weight	2.22Kg
Net Weight	1.58Kg
Includes	2 pcs battery,1 pc charger

PART LIST

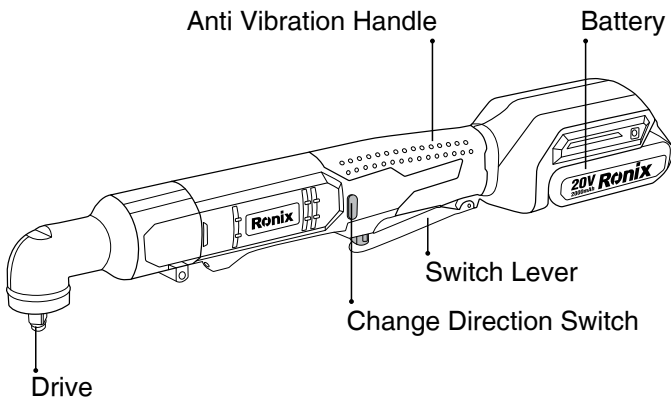

GENERAL POWER TOOL SAFETY WARNINGS

WARNING

Read all safety warnings and all instructions. Failure to follow the warnings and instructions may result in fire and/or serious injury.

■SAVE ALL WARNINGS AND INSTRUCTIONS FOR FUTURE REFERENCE.

The term “power tool” in the warnings refers to your mains operated (corded) power tool or battery operated (cordless) power tool.

■WORK AREA SAFETY

- 1- Keep work area clean and well lit. Cluttered or dark areas invite accidents.
- 2- Do not operate power tools in explosive atmospheres, such as in the presence of flammable liquids, gases or dust. Power tools create sparks which may ignite the dust or fumes.
- 3- Keep children and bystanders away while operating a power tool. Distractions can cause you to lose control.

■ELECTRICAL SAFETY

- 1- Avoid body contact with earthed or grounded surfaces such as pipes, radiators, ranges and refrigerators. There is an increased risk of electric shock if your body is earthed or grounded.
- 2- Do not expose power tools to rain or wet conditions. Water entering a power tool will increase the risk of electric shock.

■PERSONAL SAFETY

- 1- Stay alert, watch what you are doing and use common sense when operating a power tool. Do not use a power tool while you are tired or under the influence of drugs, alcohol or medication. A moment of inattention while operating power tools may result in serious personal injury.

- 2- Use personal protective equipment. Always wear eye protection. Protective equipment such as dust mask, non-skid safety shoes, hard hat, or hearing protection used for appropriate conditions will reduce personal injuries.
- 3- Prevent unintentional starting. Ensure the switch is in the off position before connecting to power source and/or battery pack, picking up or carrying the tool .
- 4- Remove any adjusting key or wrench before turning the power tool on. A wrench or a key left attached to a rotating part of the power tool may result in personal injury.
- 5- Do not overreach. Keep proper footing and balance at all times. This enables better control of the power tool in unexpected situations.
- 6- Dress properly. Do not wear loose clothing or jewellery. Keep your hair, clothing, and gloves away from moving parts. Loose clothes, jewellery or long hair can be caught in moving parts.
- 7- If devices are provided for the connection of dust extraction and collection facilities, ensure these are connected and properly used. Use of dust collection can reduce dust related hazards.

POWER TOOL USE AND CARE

- 1- Do not force the power tool. Use the correct power tool for your application. The correct power tool will do the job better and safer at the rate for which it was designed.
- 2- Do not use the power tool if the switch does not turn it on and off. Any power tool that cannot be controlled with the switch is dangerous and must be repaired.
- 3- Disconnect the plug from the power source and/or the battery pack from the power tool before making any adjustments, changing accessories, or storing power tools. Such preventive safety measures reduce the risk of starting the power tool accidentally.
- 4- Store idle power tools out of the reach of children and do not allow persons unfamiliar with the power tool or these instructions to operate the power tool. Power tools are dangerous in the hands of untrained

users.

5- Maintain power tools. Check for misalignment or binding of moving parts, breakage of parts and any other condition that may affect the power tool's operation. If damaged, have the power tool repaired before use. Many accidents are caused by poorly maintained power tools.

6- Keep cutting tools sharp and clean. Properly maintained cutting tools with sharp cutting edges are less likely to bind and are easier to control.

7- Use the power tool, accessories and tool bits etc. in accordance with these instructions, taking into account the working conditions and the work to be performed. Use of the power tool for operations different from those intended could result in a hazardous situation.

■ BATTERY TOOL USE AND CARE

1- Recharge only with the charger specified by the manufacturer.

A charger that is suitable for one type of battery pack may create a risk of fire when used with another battery pack.

2- Use power tools only with specifically designated battery packs. Use of any other battery packs may create a risk of injury and fire.

3- When battery pack is not in use, keep it away from other metal objects, like paper clips, coins, keys, nails, screws or other small metal objects, that can make a connection from one terminal to another. Shorting the battery terminals together may cause burns or a fire.

4- Under abusive conditions, liquid may be ejected from the battery; avoid contact. If contact accidentally occurs, flush with water. If liquid contacts eyes, additionally seek medical help. Liquid ejected from the battery may cause irritation or burns.

■ SERVICE

1- Have your power tool serviced by a qualified repair person using only identical replacement parts. This will ensure that the safety of the power tool is maintained.

- 2- Follow instruction for lubricating and changing accessories.
- 3- Keep handles dry, clean and free from oil and grease.

CORDLESS RATCHET WRENCH SAFETY

WARNINGS!

- 1- Hold power tool by insulated gripping surfaces, when performing an operation where the fastener may contact hidden wiring. Fasteners contacting a “live” wire may make exposed metal parts of the power tool “live” and could give the operator an electric shock.
- 2- Wear ear protectors.
- 3- Check the socket carefully for wear, cracks or damage before installation.
- 4- Hold the tool firmly.
- 5- Always be sure you have a firm footing. Be sure no one is below when using the tool in high locations.
- 6- The proper fastening torque may differ depending upon the kind or size of the bolt. Check the torque with a torque wrench.

SAVE THESE INSTRUCTIONS

WARNING!

DO NOT let comfort or familiarity with product (gained from repeated use) replace strict adherence to safety rules for the subject product. MISUSE or failure to follow the safety rules stated in this instruction manual may cause serious personal injury.

■SYMBOLS

The followings show the symbols used for tool.

V	Volt
≡	Direct Current
n.	No load speed
---/min r/min	Revolutions or reciprocation per minute
	Number of Blow

IMPORTANT SAFETY INSTRUCTIONS

■FOR BATTERY CARTRIDGE

- 1- Before using battery cartridge, read all instructions and cautionary markings on battery charger, battery, and product using battery.
- 2- Do not disassemble battery cartridge.
- 3- If operating time has become excessively shorter, stop operating immediately. It may result in a risk of overheating, possible burns and even an explosion.
- 4- If electrolyte gets into your eyes, rinse them out with clear water and seek medical attention right away. It may result in loss of your eyesight.
- 5- Do not short the battery cartridge:
 - Do not touch the terminals with any conductive material.
 - Avoid storing battery cartridge in a container with other metal objects such as nails, coins, etc.
 - Do not expose battery cartridge to water or rain.A battery short can cause a large current flow, overheating, possible burns and even a breakdown.
- 6- Do not store the tool and battery cartridge in locations where the

temperature may reach or exceed 50°C (122°F).

7- Do not incinerate the battery cartridge even if it is severely damaged or is completely worn out. The battery cartridge can explode in a fire.

8- Be careful not to drop or strike battery.

9- Do not use a damaged battery.

■ TIPS FOR MAINTAINING MAXIMUM BATTERY LIFE

1- Charge the battery cartridge before completely discharged.

Always stop tool operation and charge the battery cartridge when you notice less tool power.

2- Never recharge a fully charged battery cartridge. Overcharging shortens the battery service life.

3- Charge the battery cartridge with room temperature at 10°C - 40°C (50°F - 104°F). Let a hot battery cartridge cool down before charging it.

4- Charge the battery cartridge once in every six months if you do not use it for a long period of time.

■ FUNCTIONAL DESCRIPTION

CAUTION!

- Always be sure that the tool is switched off and the battery cartridge is removed before adjusting or checking function on the tool.

- Always switch off the tool before installing or removing of the battery cartridge.

- Hold the tool and the battery cartridge firmly when installing or removing battery cartridge.

Failure to hold the tool and the battery cartridge firmly may cause them to slip off your hands and result in damage to the tool and battery cartridge and a personal injury.

To remove the battery cartridge, slide it from the tool while sliding the button on the front of the cartridge.

To install the battery cartridge, align the tongue on the battery cartridge with the groove in the housing and slip it into place. Insert it all the way

until it locks in place with a little click. If you can see the red indicator on the upper side of the button, it is not locked completely.

! CAUTION!

- Always install the battery cartridge fully until the red indicator cannot be seen. If not, it may accidentally fall out of the tool, causing injury to you or someone around you.
- Do not install the battery cartridge forcibly. If the cartridge does not slide in easily, it is not being inserted correctly.

SWITCH ACTION

! CAUTION!

- Before inserting the battery cartridge into the tool, always check to see that the switch lever actuates properly and returns to the “OFF” position when released.

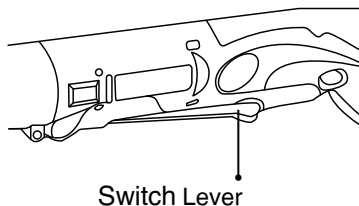

To start the tool, simply pull the switch lever. Tool speed is increased by increasing pressure on the switch lever. Release the switch lever to stop.

REVERSING SWITCH ACTION

This tool has a reversing switch to change the direction of rotation. Depress the reversing switch lever from the A side for clockwise rotation or from the B side for counterclockwise rotation.

When the reversing switch lever is in the neutral position, the switch

lever cannot be pulled.

⚠ CAUTION!

- Always check the direction of rotation before operation.
- Use the reversing switch only after the tool comes to a complete stop. Changing the direction of rotation before the tool stops may damage the tool.
- When not operating the tool, always set the reversing switch lever to the neutral position.

ASSEMBLY

⚠ CAUTION!

- Always be sure that the tool is switched off and the battery cartridge is removed before carrying out any work on the tool.

■ SELECTING CORRECT SOCKET

Always use the correct size socket for bolts and nuts. An incorrect size socket will result in inaccurate and inconsistent fastening torque and/or damage to the bolt or nut.

INSTALLING OR REMOVING SOCKET.

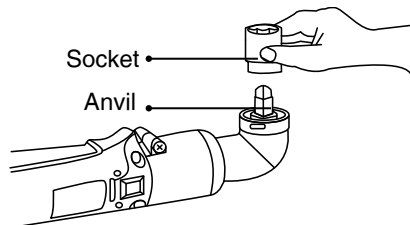

- To install the socket, push it onto the anvil of the tool until it locks into place.

- To remove the socket, simply pull it off.

MAINTENANCE

⚠ CAUTION:

- Always be sure that the tool is switched off and the Battery cartridge is removed before attempting to perform inspection or maintenance.

- Never use gasoline, benzine, thinner, alcohol or the like.

Discoloration, deformation or cracks may result.

To maintain product SAFETY and RELIABILITY, repairs, any other maintenance or adjustment should be performed by Ronix Authorized or Factory Service Centers, always using Ronix replacement parts.

OPTIONAL ACCESSORIES

⚠ CAUTION:

- These accessories or attachments are recommended for use with your Ronix tool specified in this manual.

The use of any other accessories or attachments might present a risk of injury to persons.

Only use accessory or attachment for its stated purpose.

If you need any assistance for more details regarding these accessories, ask your local Ronix Service Center.

- Sockets

- Battery and charger

⚠ NOTE:

- Some items in the list maybe include in the tool package as standard accessories. They may differ from country to country.



www.ronixtools.com