

Ronix[®]

Premium Quality

CORDLESS RECIPROCATING SAW 8621

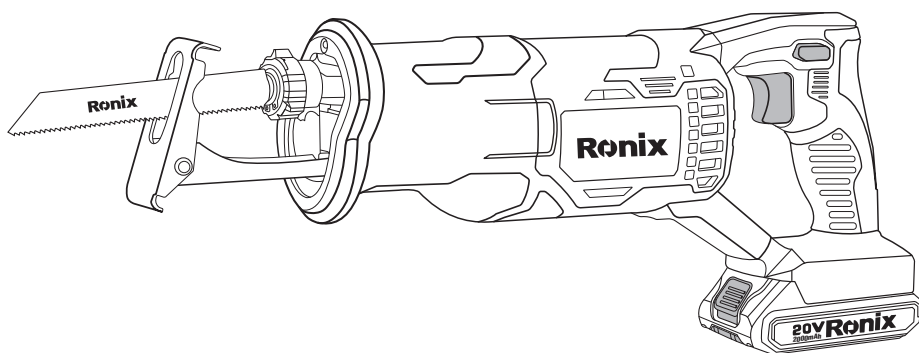

www.ronixtools.com



TECHNICAL SPECIFICATION

Model	8621
No-Load Speed	0-2900RPM
Charging Time	60min
Voltage	20V
Battery Capacity	2.0Ah
Battery Chemistry	Lithium
Cutting Depth	100mm For Wood; 8mm For Metal
Blade Material	Blade For Wood: HCS Blade For Metal: Bi-metal
Run Time	15min(2Ah battery)
Blade Length	Wood Blade: 152mm Metal Blade: 103mm
Body Material	PA6+GF30
Number Of Teeth	Wood Blade: 52T Metal Blade: 80T
Cuts Per Battery Charge (Cutting Diameter 100mm)	20pcs (with 2.0Ah battery)
Net Weight	2.5Kg
Total Weight	3.7Kg
Includes	2 Pcs Battery 1 Pc Charger 1 Pc Blade For Wood; 1 Pc Blade For Metal

PART LIST

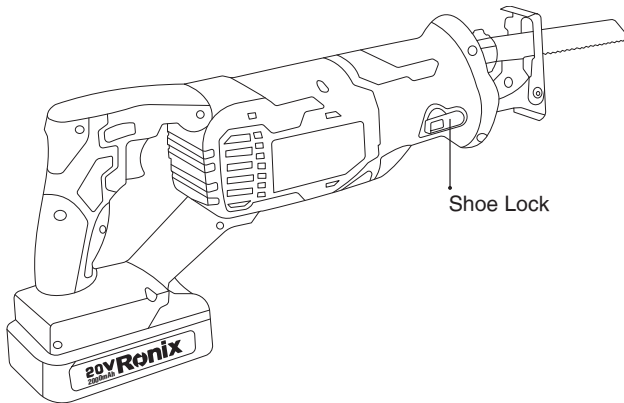
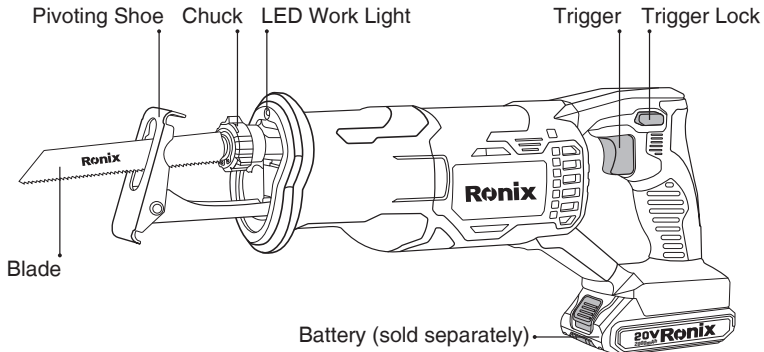

HAZARD DEFINITIONS

Please familiarize yourself with the hazard notices found in this manual. A notice is an alert that there is a possibility of property damage, injury or death if certain instructions are not followed.

⚠ DANGER!

This notice indicates an immediate and specific hazard that will result in severe personal injury or death if the proper precautions are not taken.

⚠ WARNING!

This notice indicates a specific hazard or unsafe practice that could result

in severe personal injury or death if the proper precautions are not taken.

CAUTION!

This notice indicates a potentially hazardous situation that may result in minor or moderate injury if proper practices are not taken.

NOTICE!

This notice indicates that a specific hazard or unsafe practice will result in equipment or property damage, but not personal injury.

INTRODUCTION

This cordless reciprocating saw features a high-performance motor, metal gear construction, variable-speed trigger, keyless blade changes, adjustable pivoting shoe and textured grip. It requires the Powerfist 20V cordless system Li-ion battery and charger (sold separately).

SAFETY

WARNING!

Read and understand all instructions before using this tool. The operator must follow basic precautions to reduce the risk of personal injury and/or damage to the equipment.

Keep this manual for safety warnings, precautions, operating or inspection and maintenance instructions.

WORK AREA

- 1- Operate in a safe work environment. Keep your work area clean, well-lit and free of distractions. Place lights so you are not working in a shadow.
- 2- Keep anyone not wearing the appropriate safety equipment away from the work area.
- 3- Store unused tools properly in a safe and dry location to prevent rust

or damage. Lock tools away and keep out of the reach of children.

4- Do not install or use in the presence of flammable gases, dust or liquids.

PERSONAL SAFETY

⚠ WARNING!

Wear personal protective equipment approved by the Canadian Standards Association (CSA) or American National Standards Institute (ANSI).

PERSONAL PROTECTIVE EQUIPMENT

1- Always wear impact safety goggles that provide front and side protection for the eyes. Eye protection equipment should comply with CSA Z94.3-07 or ANSI Z87.1 standards based on the type of work performed.

2- Wear the appropriate type of full-face shield in addition to safety goggles, as the work can create chips, abrasive or particulate matter.

3- Do not wear gloves when operating a tool that can snag the material and pull the hand into the tool.

4- Wear protective clothing designed for the work environment and tool.

5- Non-skid footwear is recommended to maintain footing and balance in the work environment.

6- Wear steel toe footwear or steel toe caps to prevent a foot injury from falling objects.

7- Wear the appropriate rated dust mask or respirator.

8- This tool can cause hearing damage. Wear hearing protection gear with an appropriate Noise Reduction Rating to withstand the decibel levels.

PERSONAL PRECAUTIONS

Control the tool, personal movement and the work environment to avoid personal injury or damage to tool.

- 1- Do not operate any tool when tired or under the influence of drugs, alcohol or medications.
- 2- Avoid wearing clothes or jewelry that can become entangled with the moving parts of a tool. Keep long hair covered or bound.
- 3- Do not overreach when operating a tool. Proper footing and balance enables better control in unexpected situations.
- 4- Securely hold this tool using both hands. Using a tool with only one hand can result in loss of control.

POWER TOOL PRECAUTIONS

- 1- Do not use any power tool with a malfunctioning power switch or control. A power tool that fails to respond to the controls is dangerous and can cause an injury. A qualified technician must repair and verify the power tool is operating correctly, before it can be used.
- 2- Do not cover the air vents. Proper cooling is necessary prevent damage to the tool's motor.
- 3- Avoid unintentional starts. Ensure the switch is off when connecting to the power source.
- 4- Disconnect the power source before installing or servicing the tool.
- 5- Remove adjusting keys and wrenches before using the tool. The tool may eject an attached wrench or a key and cause an injury to you or a bystander.
- 6- Never point the tool towards yourself. It could inflict an injury.
- 7- Never force the tool. Excessive pressure could break the tool, resulting in damage to your workpiece or serious personal injury. Excessive pressure is the cause if your tool runs smoothly under no load, but roughly under load.
- 8- Keep hands and fingers away from the work area. Any part of the

body contacting the tool's working parts could result in an injury.

9- Only use accessories that are specifically designed for use with the tool. Ensure the accessory is tightly installed.

10- Only use an accessory that exceeds the Speed Rating (see Specifications).

11- Before using the tool on a workpiece, test the tool by running it at the highest Speed Rating for at least 30 seconds in a safe position. Stop immediately if there is any abnormal vibration or wobbling. Check the tool to determine the cause.

a- Do not allow the tool to run without load for an extended period of time, as this will shorten its life.

12- Never touch the tool accessory or workpiece during or immediately after use. They may be hot and could inflict a burn injury.

13- Take work breaks to prevent the tool's motor from overheating and/or overloading.

14- Never use a tool with a cracked or worn tool accessory. Change the tool accessory before using it.

15- Do not start the tool when the tool's accessory is touching the workpiece.

ELECTRICAL SAFETY

WARNING!

Do not touch or handle a live tool with any part of your body that is wet or damp. Wet skin reduces resistance to electrical current, increasing the danger of a serious or fatal shock.

1- Do not alter any parts of the tool or accessories. All parts and accessories are designed with built-in safety features that may be compromised if altered.

2- Protect yourself against electric shocks when working on electrical equipment. Avoid body contact with grounded surfaces. There is an increased chance of electrical shock if your body is grounded.

3- Do not expose the saw to rain, snow, frost or any other damp or wet conditions. Water entering a tool will increase the risk of electric shock.

BATTERY SAFETY

WARNING!

Only charge a battery with a charger designed for that purpose. Do not use modified chargers or a charger that does not specify the voltage, amperage or recharge rate. Improper charging can lead to battery rupturing.

WARNING!

Do not charge a damaged or frozen battery. Contact your local municipality for proper disposal procedures. Consult the Safety Data Sheet (SDS) for your battery before use or maintenance.

1- Do not expose the battery to heat or throw it in a fire. The contents are flammable and the battery may explode. Remove any source of ignition such as an open flame or a tool like a heater from the area.

2- Do not inhale smoke issuing from a burning battery, as it is toxic.

3- Do not disassemble or crush the battery as the contents are corrosive and flammable. Exposure may cause an injury. There is a risk of escaping hazardous vapors. These vapors can irritate the respiratory track. Always ensure proper ventilation and immediately consult a doctor, if you feel unwell.

4- Even a discharged battery may still carry a charge. To prevent a shock, place battery terminal caps or covers over the terminal to prevent accidental contact. Hold the battery by the bottom if moving the battery to a different location.

5- Do not store the battery in containers / spaces with loose metal objects. Keep it away from other metal objects that can make a connection between terminals. Shorting out the battery terminals may cause burns or a fire.

6- A battery-operated tool with internal batteries or with a separate battery pack must only be powered by the included battery. Do not mix different brands of tools and batteries or use adapters to allow you to use a battery pack with a different voltage. This can damage the tool's electrical mechanism and create

a fire hazard.

7- If fluids leak from the battery, avoid contact. Leaking battery fluid can cause irritation of the skin or burns. If contact should occur, flush immediately with water. In case of accidental contact with the eyes, seek medical aid.

8- Do not disconnect from the power source in place of using the ON/OFF switch on the tool. This can lead to an accidental startup when the tool is connected to the power supply.

9- Do not allow a rechargeable battery to fully discharge. This will damage the battery. Recharge the battery as soon as possible.

10- Do not store the battery completely discharged. Charge it fully before storing. Recharge occasionally if storing for a long time.

CHARGER PRECAUTIONS

WARNING!

Voltage is present at the charging terminals, do not probe with conductive objects. Electric shock or electrocution may result. A battery short can cause a large current flow, overheating, possible burns and even a breakdown of the tool.

Before using the charger, read all instructions and cautionary markings on the charger, battery pack and the product using the battery pack.

1- Only use the included battery charger to recharge the battery. Other chargers may be unsafe, causing an electrical short circuit or fire.

2- Disconnect the charger from its power source before attaching or removing batteries or battery clamps.

3- Charge the battery in a well-ventilated area and never obstruct the vents in the top and bottom of the charger. Place the charger on a flat nonflammable surface and away from flammable materials when re-charging the battery.

4- Do not place any object on top of the charger or place the charger on a soft surface that may result in excessive internal heat. Place the charger in a position away from any heat source.

5- Charge the battery at rates recommended by the battery manufacturer.

6- Do not insert the battery into the charger backwards. Make sure the polarity

symbols on the battery lines up with the polarity symbols of the charger. A battery inserted backwards may explode causing fire and/or injury.

7- Do not use the charger with an extension cord. This can cause a low voltage outage during charging.

8- Do not charge leaking batteries. A compromised casing will release volatile chemicals and gases. Charging a leaking battery can cause a fire or explosion.

9- Do not operate the charger if it has received a sharp blow, been dropped or otherwise damaged in any way. Have it serviced or replaced.

SPECIFIC SAFETY PRECAUTIONS

WARNING!

DO NOT let comfort or familiarity with product (gained from repeated use) replace strict adherence to the tool safety rules. If you use this tool unsafely or incorrectly, you can suffer serious personal injury.

1- Use the correct tool for the job. This tool was designed for a specific function.

Do not modify or alter this tool or use it for an unintended purpose.

2- Do not use the tool if any parts are damage broken or misplaced. Repair or replace the parts.

CUTTING PRECAUTIONS

WARNING

Some surfaces contain materials which can be toxic. When working on materials that may contain lead, asbestos, copper chromium arsenate or other toxic materials, extra care should be taken to avoid inhalation and minimize skin contact.

1- Only use accessories that are specifically designed for use with the tool. Ensure the accessory is tightly installed.

2- Use caution when cutting damp wood, pressure treated lumber or wood containing knots. Adjust speed of cut to maintain smooth advancement of tool without decrease in cutting accessory speed.

3- Do not use a dull or damaged cutting accessory. A dull cutting accessory

requires more force to use the tool, possibly causing the accessory to break. This may cause an injury and will damage the workpiece.

a- Dull or improperly set cutting accessories produce a narrow kerf that can cause excessive friction on the cutting accessory, resulting in binding or a kickback. Keep the cutting accessory's edge sharp and clean.

4- Only use a cutting accessory that exceeds the No Load Speed rating (see Specifications).

5- Always wait until the motor has reached full speed before starting a cut.

CUTTING TOOL PRECAUTIONS

1- Use the correct mounting hardware. The mounting hardware is designed to hold the cutting accessory on the tool to allow optimum performance and safety of operation. Mismatched mounting hardware may result in a tool malfunction and cause an injury.

a- Always use blades that are correctly sized and shaped for the tool. Blades that do not match the tool's mounting hardware will run erratically, causing loss of control.

2- Check the cutting accessory for damage before each use. A damaged accessory can break during use and cause serious injury.

3- Inspect material for foreign objects such as staples, nails or debris. Remove from material before cutting.

4- Affix the workpiece to a stable platform to prevent movement, minimize body exposure to injury, cutting accessory binding or loss of control.

5- Position the tool on the larger section of a supported workpiece to complete a cut. Cut the small portion away from the larger portion. Support the smaller portion if possible to prevent it from binding when the cut is almost complete.

6- Never confine the part of the workpiece being cut away by holding, clamping or using length stops against it. That part of the workpiece

could become wedged against the blade and be thrown violently. The cut away part of the workpiece must be free to move sideways

RECIPROCATING SAW PRECAUTIONS

DANGER!

When the tool is in operation, keep hands away from the saw blade and the area it is being applied to. Failure to follow this warning will result in amputation, serious personal injury or death.

- 1- Always make sure the reciprocating saw is clean before using.
- 2- Always handle the reciprocating saw blade with care when mounting or removing it.
- 3- Always be aware of the position of your hands relative to the blade. Avoid awkward hand positions where a sudden slip could cause a hand to move into the blade.
- 4- Never reach behind or beneath the blade.

KICKBACK PRECAUTIONS

Kickback is a sudden reaction to a pinched or snagged cutting accessory. The tool kicks out and away from the workpiece while the cutting accessory is still active. This can inflict a serious injury on the user or a bystander. Kickback can also damage the tool or workpiece.

Kickback can be avoided by taking proper precautions:

- 1- Maintain a firm grip on the tool and position your body and arms to allow you to resist a kickback. Kickback will propel the tool in the direction opposite to the cutting accessory's teeth or direction of rotation. A snagged rotary cutting bit may pull the tool out of the grasp of the user.
- 2- If kickback occurs:
 - a- The cutting accessory may pass over a body part, causing a seriously injury;
 - b- A rotary bit may wrench the user's arm causing muscle or joint injuries; and

- c- The tool may strike bystanders.
- 3. Use clamps or a vice to hold down smaller workpieces.
- 4- Use special care when working on corners, sharp edges or flexible material. These workpieces have a tendency to snag the cutting accessory.
- 5- When the blade is the binding, or when interrupting a cut for any reason, release the trigger and hold the saw motionless in the material until the blade comes to a complete stop. Never attempt to remove the saw from the workpiece or pull the saw backward while the blade is in motion as kickback may occur. Investigate and take corrective actions to eliminate the cause of blade binding.
- 6- When restarting a saw in the workpiece, center the saw blade in the kerf and check that saw teeth are not engaged into the material. If saw blade is binding, it may walk up or kickback from the workpiece as the saw is restarted.
- 7- Support large panels to minimize the risk of blade pinching and kickback. Large panels tend to sag under their own weight. Supports must be placed under the panel on both sides, near the line of cut and near the edge of the panel.
- 8- Use extra caution when making a plunge cut into existing walls or other blind areas. The protruding blade may cut objects that can cause kickback.

VIBRATION PRECAUTIONS

- 1- This tool vibrates during use. Repeated or long-term exposure to vibration may cause temporary or permanent physical injury. Take frequent breaks when using the tool.
- 2- If you feel any medical symptoms related to vibrations (such as tingling, numbness, and white or blue fingers), seek medical attention as soon as possible.
- 3- Wear suitable gloves to reduce the effects of vibration.
- 4- DO NOT use this tool before consulting a physician if one of the

following applies:

- a- Pregnant
- b- Impaired blood circulation to the hands
- c- Past hand injuries
- d- Nervous system disorders
- e- Diabetes
- f- Raynaud's Disease

UNPACKING

WARNING

Do not operate the tool if any part is missing. Replace the missing part before operating. Failure to do so could result in a malfunction and personal injury.

Remove the parts and accessories from the packaging and inspect for damage.

Make sure that all items in the Identification Key are included.

ASSEMBLY & INSTALLATION

Letter references in parenthesis (A) refer to the included Identification Key.

INSTALL EXTERNAL BATTERY PACK

WARNING

Avoid unintentional starts by ensuring the trigger lock (B) is engaged before installing the battery pack.

1- Check the battery power level before each use.- Make sure there are no electrical cables, gas pipes, etc., that can cause a hazard if damaged by use of the tool.

a- The battery is not fully charged out of the carton. Charge the battery before first use.

2- Install the battery by aligning the rib on the battery with the groove on

the battery port and push forward until the latch clicks.

3- Remove the battery by pushing the battery lock button and pulling the battery free.

INSTALLING THE BLADE

IMPORTANT!

Coarse blades are ideal for cutting wood, plastics and composites. Fine blades are ideal for cutting metal. When cutting metal, lightly oil the blade to prevent it from overheating.

1- Twist the chuck (F) counterclockwise to open.

2- Insert the blade (E) into the chuck.

3- Release the chuck to close.

4- Ensure that the blade is securely locked and that the teeth are pointing downwards.

ADJUSTING THE PIVOTING SHOE LENGTH

1. Move the shoe lock (H) into the unlocked  position.

2. Pull the shoe assembly into or away from the housing until it reaches the desired length.

3. Move the shoe lock into the locked  position.

OPERATION

WARNING

Do not attempt to cut a workpiece that is thicker than a fully retracted blade. This prevents the blade from striking the workpiece and shattering from the impact. Refer to Fig. 1.

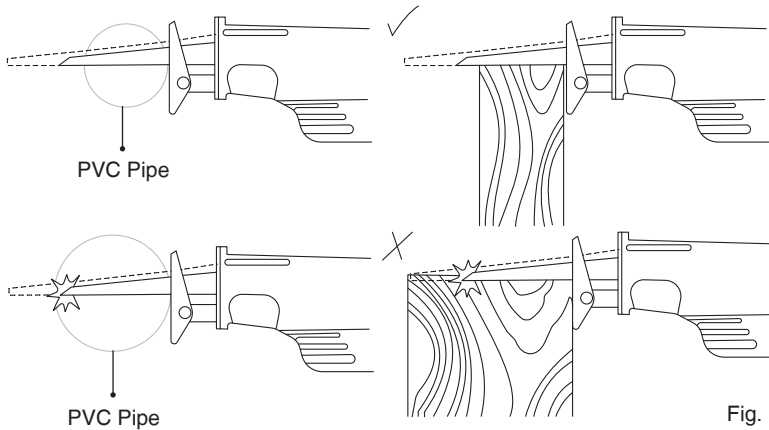

Fig. 1

- 1- Hold the reciprocating saw firmly with both hands. Position the blade near the work piece.
- 2- Push in and hold the trigger lock (B), then press the trigger (A).
- 3- Allow the blade to reach full speed before contacting the workpiece.
- 4- Press the pivoting shoe assembly against the surface to be cut. Align the saw blade along the direction of the cut. Slowly tilt the saw forward to lower the blade into the workpiece.

! WARNING

Do not bend or twist the blade or attempt to cut with the tip as it may cause kickback and blade damage.

! IMPORTANT!

Use a fine blade or cut at a higher speed if chattering or vibration occurs. Replace the blade if the saw overheats or clogs.

- 5- After completing the cut, release the trigger.

CARE & MAINTENANCE

- 1- Maintain the tool with care. A tool in good condition is efficient, easier to control and will have fewer problems.
- 2- Inspect the tool components periodically. Repair or replace damaged or

worn components. Only use identical replacement parts when servicing.

3- Only use accessories intended for use with this tool.

4- Keep the tool handles or gripping surfaces clean and dry.

5- Maintain the tool's labels and name plates. These carry important information. If unreadable or missing, contact Princess Auto Ltd. for replacements.

6- Clear the vents of any dirt, dust and debris on a regular basis to prevent the tool from overheating.

WARNING

Only qualified service personnel should repair the tool. An improperly repaired tool may present a hazard to the user and/or others.

BATTERY MAINTENANCE

Avoid the risk of battery short circuits during transport, storage or disposal by isolating both terminals with adhesive tape or pack the battery in a plastic bag or a cardboard box.

1- The longest life and best performance can be obtained if the battery pack is charged when the air temperature is between 50 to 86°F (10 to 30°C). Do not charge the battery when the temperature is below 32°F (0°C) or above 104°F (40°C). This is important and will prevent damage to the battery pack.

2- Charge the battery at rates recommended by the manufacturer.

CLEANING

1- Remove all swarf from the machine with a vacuum cleaner or compressed air. Focus on removing dust from the motor's fan vents.

2- Thoroughly clean all surfaces.

CLEANING THE CHARGER

1- Only clean with a damp cloth. Avoid using solvents when cleaning

plastic parts.

2- To reduce risk of electric shock, unplug the charger from the outlet before attempting any cleaning. Removing the battery pack will not reduce this risk.

STORAGE

When not in use for an extended period, apply a thin coat of lubricant to the steel parts to avoid rust. Remove the lubricant before using the tool again.

- 1- Components should be kept dry, with machined surfaces lightly oiled.
- 2- Always remove the saw blade and store in a safe place.
- 3- Never store equipment in a wet/damp environment.

BATTERY STORAGE

Remove the battery when not in use for an extended period of time to prevent damage.

- 1- Do not store the battery completely discharged. Charge it fully before storing. Recharge occasionally if storing for a long time.
- 2- Do not store batteries in containers / spaces with loose metal objects. Battery terminals could be short circuited if they come into contact with metal objects. In addition to damaging the battery, you increase the risk of a fire.

DISPOSAL

Recycle a tool damaged beyond repair at the appropriate facility. Contact your local municipality for a list of disposal facilities or by-laws for electronic devices, batteries, oil or other toxic liquids.

TROUBLESHOOTING

Visit a Princess Auto Ltd. location for a solution if the tool does not function properly or parts are missing. If unable to do so, have a qualified technician service the tool.

Problem(s)	Possible Cause(s)	Suggested Solution(s)
<p>The saw will not start.</p>	<ol style="list-style-type: none"> 1- Supplied power is interrupted. 2- On/Off switch is faulty. 3- Motor components are short-circuiting or are defective. 4- Motor has overheated. 5- The battery is not installed correctly. 6- Battery power depleted. 7- Battery is worn out. 	<ol style="list-style-type: none"> 1- Check that power supply is still available. 2- Replace faulty switch. 3- Have a qualified technician service the tool. 4- Allow motor to cool before attempting to use. 5- Clean battery contacts individually to avoid a shock. Then install the battery correctly. Make sure the polarity matches and the battery locks into place. 6- Follow instructions to charge the battery in Care & Maintenance. 7- Replace with a new battery from the same manufacturer. Dispose or recycle your old battery according to your local municipal bylaws.
<p>Motor starts slow and doesn't reach operation speed.</p>	<ol style="list-style-type: none"> 1- Motor is damaged. 2- The battery has insufficient charge. 3- Battery is worn out. 	<ol style="list-style-type: none"> 1- Have a qualified technician service the tool. 2- Follow instructions to charge the battery in Care & Maintenance. 3- Replace with a new battery from the same manufacturer. Dispose or recycle your old battery according to your local municipal bylaws.

<p>Tool is making unusual sounds</p>	<p>1- The saw's parts may be rubbing or binding. 2- Electrical components may be shorting.</p>	<p>1- Check for obstructions or misaligned tool components. Lubricate, repair or replace the components based on the particular problem. 2- Disconnect tool from the power source immediately. Have the tool examined by a qualified technician.</p>
<p>Heavy sparking inside motor housing.</p>	<p>Motor is shorting.</p>	<p>Disconnect tool from the power source immediately. Have the tool examined by a qualified technician.</p>
<p>Overheating</p>	<p>1- Forcing machine to work too fast. 2- Blocked motor housing vents.</p>	<p>1- Allow machine to work at its own rate. 2- Keep the blade sharp. Replace as needed 3- Blow dust out of motor using compressed air.</p>



www.ronixtools.com