

Ronix[®]

Premium Quality

CUT-OFF SAW

5901

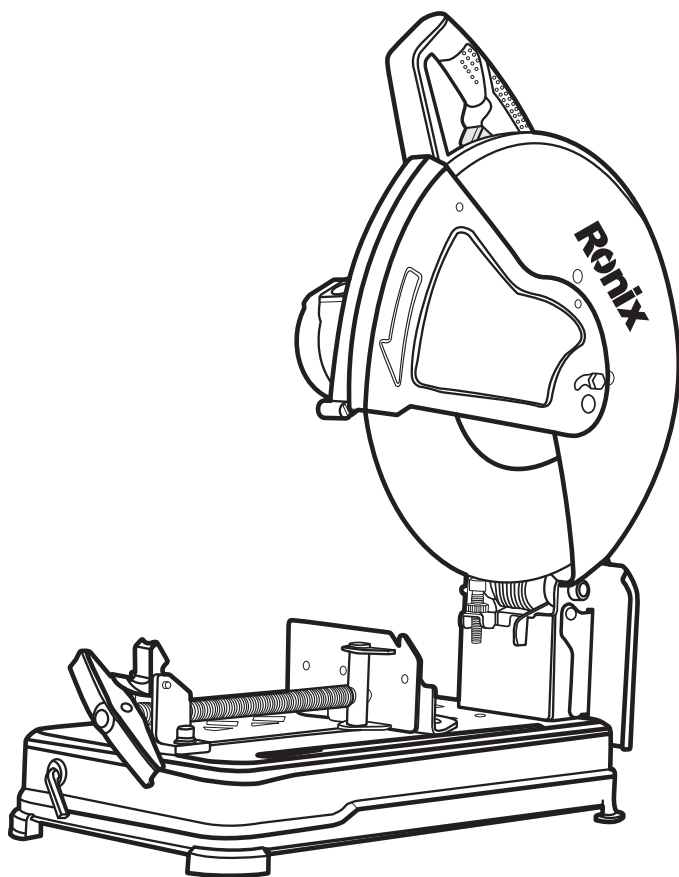

www.ronixtools.com

SPECIFICATION

Model	5901
Power	2300W
Voltage	220-240V
Frequency	50-60Hz
No-Load Speed	4000RPM
Blade Diameter	355mm
Max Cutting Capacity	Round Steel 130mm
	Square Steel 120mm
	Rectangle Steel 120×130mm
	Angle Steel 140×140mm
Net Weight	17Kg

PART LIST

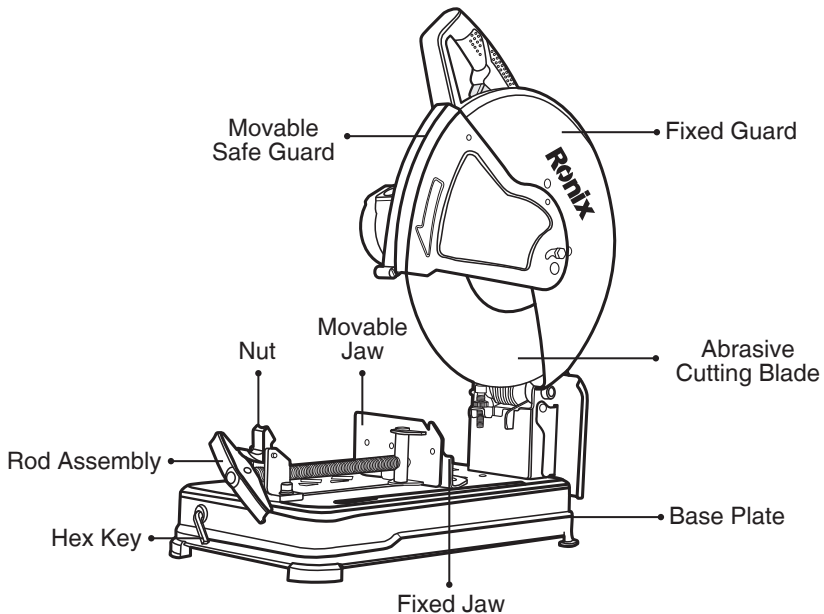

GENERAL SAFETY INSTRUCTIONS

WARNING!

Read all instructions. Failure to follow all instructions listed below may result in electric shock, fire and /or serious injury.

The term “power tool” in all of the warnings listed below refers to your mains operated power tool.

SAVE THESE INSTRUCTIONS

■ **WORK AREA**

- Keep work area clean and well lit. Cluttered and dark areas invite accidents.
- Do not operate power tools in explosive atmospheres, such as in the presence of flammable liquids, gases or dust. Power tools create sparks which may ignite the dust or fumes.
- Keep children and bystanders away while operating a power tool. Distractions can cause you to lose control.

■ **ELECTRICAL SAFETY**

- Power tool plugs must match the outlet. Never modify the plugs in any way. Do not use any adapter plugs with earthed power tools. Unmodified plugs and matching outlets will reduce risk of electric shock.
- Avoid body contact with earthed or grounded surfaces such as pipes, radiators, ranges and refrigerators. There is an increased risk of electric shock if your body is earthed or grounded.
- Do not expose power tools to rain or wet conditions. Water entering a power tool will increase the risk of electric shock.
- Do not abuse the cord. Never use the cord for carrying, pulling or unplugging the power tool. Keep cord away from heat, oil, sharp edges or moving parts. Damaged or entangled cords increase the risk of electric shock.
- When operating a power tool outdoors, use an extension cord suitable for outdoor use. Use of a cord suitable for outdoor use reduces the risk of electric shock.
- If operating a power tool in a damp location is unavoidable, use a

residual current device (RCD) protected supply. Use of an RCD reduces the risk of electric shock.

■ PERSONAL SAFETY

- Stay alert, watch what you are doing and use common sense when operating a power tool. Do not use a power tool while you are tired or under the influence of drugs, alcohol or medication. A moment of inattention while operating power tools may result in serious personal injury.
- Use safety equipment. Always wear eye protection. Safety equipment such as dust mask, no-skid safety shoes, hard hat, or hearing protection used for appropriate conditions will reduce personal injuries.
- Avoid accidental starting. Ensure the switch is in the off position before plugging in. Carrying power tools with your finger on the switch or plugging in power tools that have the switch on invites accidents. Prevent unintentional starting. Ensure the switch is in the off-position before connecting to power source and/or battery pack, picking up or carrying the tool. Carrying power tools with your finger on the switch or energizing power tools that have the switch on invites accidents.
- Remove any adjusting key or wrench before turning the power tool on. A wrench or a key left attached to a rotating part of the power tool may result in personal injury.
- Do not overreach. Keep proper footing and balance at all times. This enables better control of the power tool in unexpected situations.
- Dress properly. Do not wear loose clothing or jewelry. Keep your hair, clothing and gloves away from moving parts. Loose clothes, jewelry or long hair can be caught in moving parts.
- If devices are provided for the connection of dust extraction and collection facilities, ensure these are connected and properly used. Use of these devices can reduce dust related hazards.

■ POWER TOOL USE AND CARE

- Do not force the power tool. Use the correct power tool for your application. The correct power tool will do the job better and safer at

the rate for which it was designed.

- Do not use the power tool if the switch does not turn it on and off. Any power tool that cannot be controlled with the switch is dangerous and must be repaired.
- Disconnect the plug from the power source before making any adjustment, changing accessories, or storing power tools. Such preventive safety measures reduce the risk of starting the power tool accidentally.
- Store idle power tools out of the reach of children and do not allow persons unfamiliar with the power tool or these instructions to operate the power tool. Power tools are dangerous in the hands of untrained users.
- Maintain power tools. Check for misalignment or binding of moving parts, breakage of parts and any other condition that may affect the power tools operation. If damaged, have the power tool repaired before use. Many accidents are caused by poorly maintained power tools.
- Keep cutting tools sharp and clean. Properly maintained cutting tools with sharp cutting edges are less likely to bind and are easier to control.
- Use the power tool, accessories and tool bits etc., in accordance with these instructions and in the manner intended for particular type of power tool, taking into account the working conditions and the work to be performed. Use the power tool for operations different from those intended could result in a hazardous situation.
- Save all warnings and instructions for future reference.

■ SERVICE

Have your power tool serviced by a qualified repair person using only identical replacement parts.

This will ensure that the safety of the power tool is maintained.

IMPORTANT:

Hold power tool by insulated gripping surfaces, when performing an operation where the cutting accessory may contact hidden wiring or its own cord. Cutting accessory contacting a “live” wire may make exposed metal parts of the power tool “live” and could give the operator an electric shock.

■ SAFETY

- Read these instructions before operating this power tool. They contain information which will enable you to use the tool safely and help protect those around you.
- A copy of this instruction leaflet should be kept with the tool so that you can refer to it quickly when undertaking work. Another copy should be made and safely away.
- The cut off machine must be put on the ground to use (Do not equip it on the working table).
- Pay attention to the highest rotational speed limitation indicated on the cutting wheel; do use it according to the stipulations. It's limited to use the glass fiber reinforce cutting wheel with safety linear velocity not less than 80m/s. It's forbidden to use any other grinding cutting disk.
- Do check if there's any fissure or damage situation of the cutting wheels before using the machine every time. If there's such situation, it must be replaced to avoid any accidents
- Do equip the cutting wheel according to the operation explanations, use wrench to fix the cutting wheel carefully, it's possible to occur dangers if equips too loose; and it'll damage the cutting wheel if equips too tight.
- Key factors of inspection in trial operation:
 - Check the cutting wheel firstly to confirm its model is conforming to the requirements of the machine type; the cutting wheel is in good and complete condition. At the time of starting up the machine, don't touch the materials, to ensure it's starting up under idling condition. In trial operation, please keep a little far away from the machine to avoid any possible accidents.
 - Please close the current source at once if the cutting wheel stops, gives noises or vibrates.
 - The processing project must be clamped tightly, or it's possibly to occur dangers due to the dithering of the project: Make use of the silk rod handle and plier's plate to clamp the object tightly, hinge on the base plate and graduation plate to make processing.
 - Please note if the machine is equipped in level, the cushion block can

be put under the other end of long project.

- Please check the guard apparatus is normal and effective or not before operating the machine.
- After switching on, please wait for the cutting wheel rotates with full speed, and then begin to cut the project.
- Wear gloves and eye protector to avoid rebound and sustain an injury, don't wear too loose clothes and the clothes which easy to be reeled and tore. Please take notice of bundling your hair if with long hair to avoid the danger that the hair is reeled into the machine.
- Do use the cutting wheel which edge has been grinded very sharp.
- The hands and body can't approach the rotating cutting wheel too near, and of course can't touch the rotating cutting wheel. Do close the current source when disassembling, draw out the plug, and please don't make such operation until the cutting wheel stops completely. If needing to clamp the object or changing the position and angle of the project, please wait for the tool stops and then make above-said operations.
- The temperature is very high of project part that is just cut off; don't touch it to avoid scald.
- It will decrease the hardness of the cutting wheel if storing it in moist place, please store it in drying place when not use it, lay it in level to avoid distortion.
- Don't damage the axel, pressure board and bolts of the machine, or it will damage the cutting wheel during the course of assembling it.
- Don't move the protective shield of cutting wheel because of minding troubles, or lock the safety protective equipment.
- It's limited to use the pressure plate attached in the machine.

OPERATION

■ ASSEMBLE OR DISASSEMBLE THE CUTTING WHEEL

Before assemble or disassemble the cutting wheel, please make sure the machine is switched off or unplugged in. The linear velocity of all the cutting wheels should be no less than 70m/s. The diameter of all cutting wheel

should be no less than 355mm. Wrench put in the base-wrench, can be removed when required.

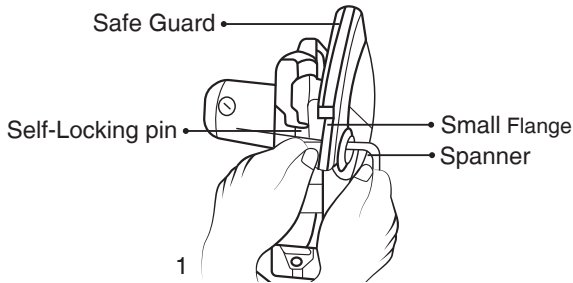

When disassemble the cutting wheel, firstly pull up the movable safety guard and press the self-locking pin to fix the cutting wheel; unscrew the hex bolt counterclockwise with wrench; and then take down the flange and the cutting wheel.

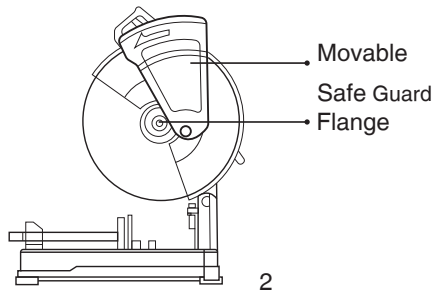

When assemble the cutting wheel, the steps are opposite to the above-said steps (Picture one, Picture Two, Picture Three)

Make sure to tighten the hex bolts. If not fully tightened, it would lead to injuries. Please use the supplied wrench to tighten the bolts.

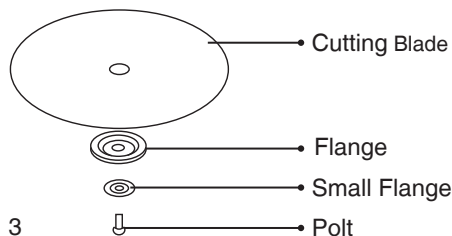

When the cutting wheel is wearing out, it can also be used economically and efficiently by adjusting the height of hexagonal bolts to control the cutting angle.

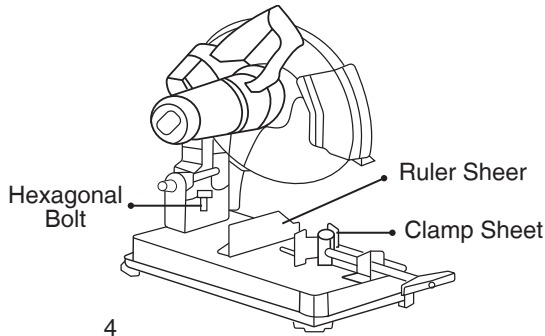

■ THE INTERSPACES BETWEEN THE PLIERS PLATE AND GRADUATION PLATE

The fixed distance is 0-170MM (0-6 11/16 inch) between plier's plate and graduation plate, if needing wider interspaces, please adjust the interspaces according to the under mentioned procedures.

Discharge two hexagonal bolts of the fixed graduation plate, move it like the picture stated, after that, fix the hexagonal bolt. According to the adjusting step, it can attain the under mentioned interspaces setting range. 35-205 MM, 70-240 MM.

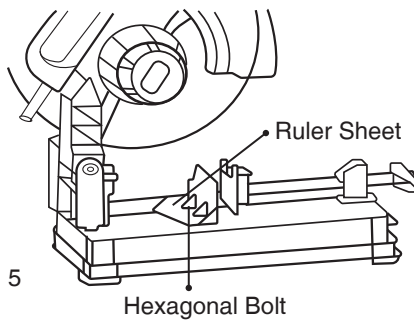

■ SETTING OF CUTTING ANGLE

Release the quick-lock device, Move the scale plate to the intended

cutting angle (0-45°), and screw the quick-lock device tightly (Picture 4). When the scale plate is set between 35-225mm or 70-260 mm, it cannot perform diagonal cutting work.

■ FIXING WORK PIECE

Turn the handle counter clockwise to lose the movable vice jaw move the fast nut upward so that the handle can be quickly pulled out or pushed forward. When pressing the work piece, firstly push forward the handle until the vice jaw reaches the work piece, then press the fast nut downwards and turn the handle clockwise to fix the work piece (Picture 6). When fixing the work piece, make sure to press the fast nut downwards completely; if not, the work piece cannot be fully clamped, and pop out cause damage to the cutting wheel.

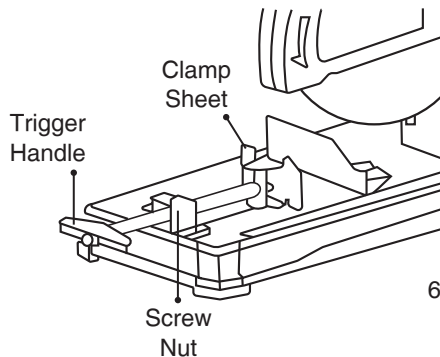

When the cutting wheel is worn out greatly, put a nonflammable hard cushion under the back of the work piece, thus it can use the middle edge of the cutting wheel to cut the object efficiently.

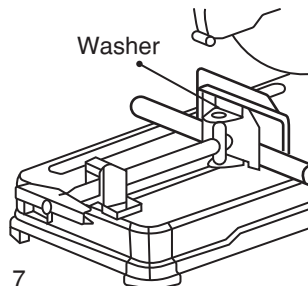

Only when cutting small object and the object can be fully clamping may the cushion be used in this manner.

Putting a cushion underneath that is narrower than the object, the cutting wheel will be used more economically and efficiently.

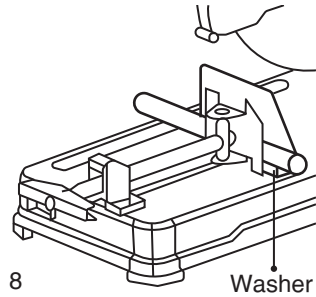

When cutting long object, put two nonflammable cushions under two ends of it, and make the object to keep in level with the pan base, ensure the supporting plain of the two cushions an the supporting plain of the base plate in a straight line.

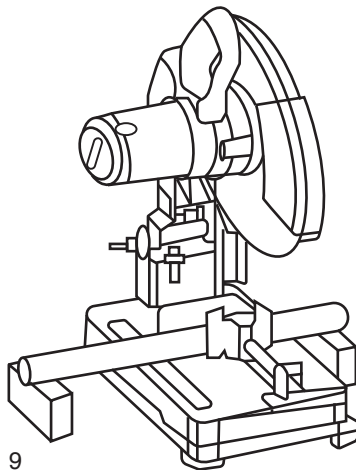

Press the switch trigger of the machine, it switches on; loose the trigger completely, the machine is under switch off condition. The machine switch can be locked if needing to make the machine runs

continuously please press the locking button at the time of pressing the switch trigger completely, the machine will be under working condition. If need to release the locking, press the switch trigger again.

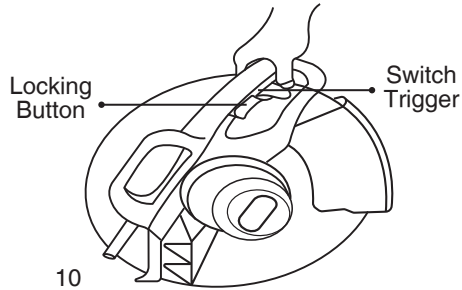

■ OPERATION

Hold the handle firmly, start up the machine until the cutting wheels reach enough rotational speed and then press the cutting wheel slowly. When the cutting wheel touches the object, press the handle sustained, apply cutting operation. When the cutting finishes, switch off the machine firstly until the cutting wheel stops rotation completely, and then lift the handle to enough high position.

■ CARRYING OF THE TOOLS PRESS

The machine body down to the lowest, and press the position limit rod switch.

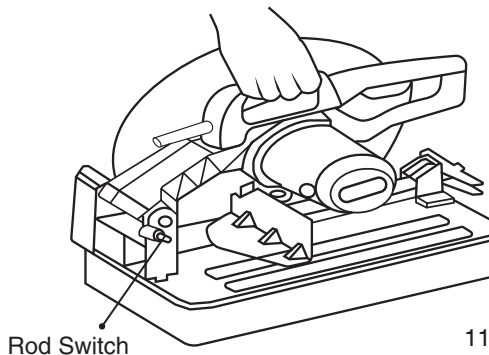

■ REPLACE THE ELECTRIC BRUSH

When the machine appears big sparks or doesn't rotate, the carbon brush is worn and less than 5MM, it needs to be replaced. Please contact **RONIX SERVICE** after sales service centers.

■ PRACTICAL TIP

- Before assembling or disassembling the cutting wheel, do confirm the machine is under switch off condition, and the plug is drawn out. The maximum circumferential velocity of the cutting wheel shall not less than 4000m/min. The maximum diameter of the cutting wheel shall not more than 355mm.
- Do confirm the hexagonal bolt is screwed tightly, if it is not screwed tightly enough, it is possible to cause injury accidents. Use the attached wrench to ensure the bolts are screwed tightly.
- Use the above mentioned big interspaced settings to cut narrow objects; the safety fixing performance is inferior.
- When setting the graduation plate under the cutting condition of 35-205MM (11/8 inch-139/16 inch) or 70-240MM (11/4 inch-151/16 inch), it can't be cut in bevel angle.
- At the time of fixing the object, do remember to press the fast nut in right turn enough, if don't make such operation, the object can't be clamped enough, thus the object will be cracked or the cutting wheel will be damaged.
- The sparks turns out from cutting decides the pressure applies on the handle is suitable or not, and if it has attained best efficiency of cutting or not. Applied pressure on the handle shall be adjusted to the maximum extend to evolve sparks, don't press the handle overmuch, otherwise, it'll decrease the cutting efficiency, wear the cutting wheel untimely, and it's possible to make the machine, cutting wheel and object damaged.

MAINTENANCE AND CARE

- Unplug the tool from the socket before performing any works on the tool!

- Tool requires no special maintenance, but after some time you must control the parts that are submitted to wear-and-tear under normal operating conditions. This includes the control and replacement of carbon brushes and grease in reducing gear housing. Take the tool to an authorized **RONIX SERVICE** service center.
- Keep the tool and supply cord clean. Keep ventilation slots clean and open. Wipe the surface of the tool with a soft cloth!
- It is not allowed to use household cleaning agents that contain petrol, trichloroethylene, ammonia and chlorides. These substances corrode and damage plastic parts of the tool.
- Excessive sparking generally indicates the presence of dirt in the motor or abnormal wear on the carbons.
- In case of electric or mechanical failure, send the tool to a **RONIX SERVICE** authorized service center for repair.

SERVICING AND REPAIRS

If servicing is required, contact one of our listed service centers. It is not allowed and dangerous to perform any individual work on the tool.

Have the tool repaired by authorized persons.

Any repairs of the tool in unauthorized service centers is performed at own responsibility.

The owner of the tool is responsible for all works on the tool that were not performed in **RONIX SERVICE** authorized service center, and therefore he loses the claim for guarantee.

Ronix[®]
Premium Quality