

# Ronix<sup>®</sup>

Premium Quality

## **GASOLINE HEDGE TRIMMER 70cm**

### **4965**

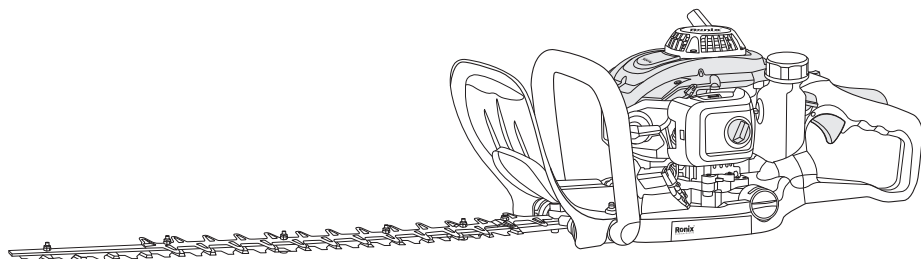



## TECHNICAL SPECIFICATION

Model	<b>4965</b>
Engine Type	2 strokes
Ignation Type	CDI
Maximum Power Output	0.8 hp (0.6kw) at 7500RPM
Displacement	22.5(cc)
Dimensions (LXWXH)	1080mmx250mmx250mm
Blade Length	700mm
Blade Material	65Manganese
Maximum Cutting Diameter	28mm
Cutting Capacity	550mm
Noise Level (Lpa)	112dB
Fuel Tank Volume	0.58 lit
Fuel Type	Pure Gasoline (no ethanol)+Oil
Fuel/Oil Ratio	1:25
Speed At Maximum Power	9500±300RPM
Speed No-load Max.	3000±300RPM
Vibration	Front handle 3.225 (m/s <sup>2</sup> ) Rear handle 4.128(m/s <sup>2</sup> )
Maximum Branch Thickness to trim	20mm
Weight	6Kg
Include	Tool Kit Bag, 1pc Mix Bottle, 1pc screwdriver, 1pc spanner, 1pc spark plug wrench, 3 pcs hex key

## PART LIST

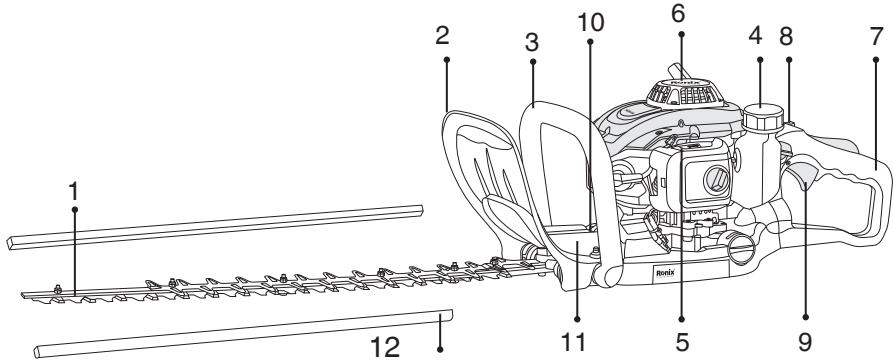

- 1- The Blade
- 2- Guard plate
- 3- Front handle
- 4- Oil can lid
- 5- Wind Gate Switch
- 6- Starter
- 7- Handle
- 8- Turn Off The Fire Switch
- 9- Throttle Trigger
- 10- Muffler
- 11- Gear Case
- 12- Blade Sheath

## SAFETY

- The hedge trimmer machine can only be used for specified purposes.
- Can start the hedge engine only after the complete assembly. The hedge machine can be permitted only after all suitable fitting installations!
- Before starting, make sure that the blade does not contact any objects, such as branches, stones, etc.
- If any engine fails, stop the engine immediately. When operating, hold

the handle with your fingers and hold it front and back. Defend Handle is cleaned, and free of water, resin, oil, or grease.

- Always stand firm body. Outdoor use only.
- Always look around and be alert to possible hazards as you may not hear them due to machine noise.
- Avoid suction gases when operating the hedge machine. Cannot operate the engine in a closed space (at risk of suffocation and gas poisoning). Carbon monoxide gas is tasteless. Always keep it well-ventilated.

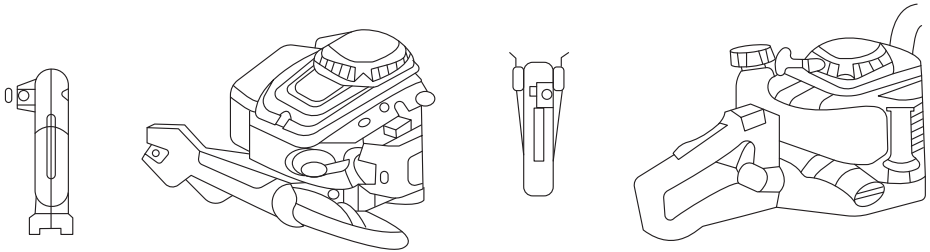

- Stop the engine when resting and when the hedge trimmer is unattended. Keep it in a safe place to prevent injury to others, ignition of combustible materials, or damage to machinery.
  - Do not place hot hedge trimmer machines on hay or any combustible material.
  - To reduce fire hazards, ensure the absence of debris, leaves, or excessive lubricants on the engine and muffler.
  - Do not operate the engine when the muffler is faulty.
- Stop the engine during transport.

## **BEFORE STOPPING THE ENGINE**

- Cleaning and blocking.
- Check, maintain, or operate the machine.
- When transported by car or truck, place the hedge trimmer machine safely to avoid oil leakage.
- When transporting the hedge trimmer machine, ensure that the fuel tank is completely empty and avoid oil leakage. Always install a blade

sheath when transporting or storing the machine.

- Stop the engine before refueling, stay away from the open fire, and do not smoke.
- Do not try to fuel the hot or running engines.
- Avoid skin contact with petroleum products. Do not inhale fuel steam. Protective gloves should be worn all during the refueling process. Change and clean the protective clothing regularly.
- Be careful not to spill fuel or lubricating oil to prevent soil contamination (environmental protection). Wipe the oil off the hedge trimmer immediately after the fuel spills. Dry in a well-ventilated area before disposing of a rag that has been wiped with fuel. Otherwise, spontaneous combustion may occur.
- Do not let the fuel to clothing. If the fuel splashes on the clothes, change the clothes immediately (very dangerous).
- Check the tank cover regularly to ensure that the tank cover is tightly secured.

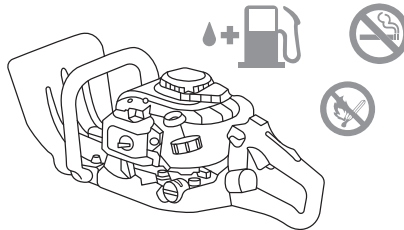

- Carefully tighten the fuel tank cover. Start the engine in another place (at least 3 m from refueling).
- Do not refuel in an enclosed space. Fuel steam accumulates on the ground (with an explosion hazard).

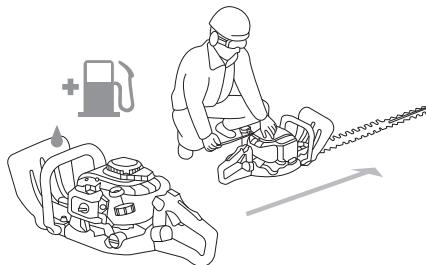

- Fuel can only be transported and stored in approved containers. Make sure that the child is not exposed to the fuel being stored.
- When gasoline is mixed with two-stroke engine oil, only gasoline without ethanol or alcohol (alcohol) can be used. This will help prevent damage to the fuel lines and other engine components. method of operation.
- Always grasp each handle with both hands while operating.
- Use a hedge trimmer machine only with good light and visibility. In the cold season, pay more attention to slippery areas, snow, and ice, etc. (at risk of slipping). Always stand firm body.
- Do not stand on unstable surfaces on steep terrain.
- Do not stand on the ladder and operate the hedge trimmer machine.
- Do not climb to the tree to use the hedge trimmer.
- To reduce the risk of tripping or runaway, do not step back while running the machine.

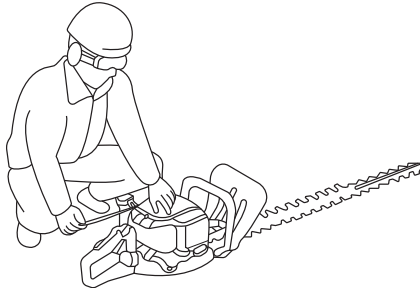

- Be sure to close the engine while cleaning, repairing the machine, or replacing the components.
- Do not operate a machine with damaged or excessively worn blades.

## **MAINTENANCE INSTRUCTIONS**

- Environmental protection . Minimize noise and pollution while operating the hedge machine. In particular, check that the carburetor is set up correctly.
- Clean the machine regularly and check that the screws and nuts

are fastened.

- Do not repair or store hedge machines near an open fire or spark, etc.
- Empty the oil pot before storing the hedge machine.
- Do not keep the machines near open fires to prevent fires.
- Store the machine at heights well-ventilated and not touched by children.
- Do not try to repair the machine without repair qualification. Please comply.
- Do not modify the hedge machine, or it will endanger your safety.
- Only the original parts or accessories authorized by the Company or provided by the factory repair center shall be used.
- In case of an accident, ensure there are well-preserved and standard first aid kits near the shear operation.

## ■ FUEL / REFUELING

Fuel and mixed oil.

- The hedge trimmer engine uses an efficient two-stroke engine. It uses a mixture of fuel oil and two-stroke engine oil. The engine was designed to use unleaded-free conventional fuel.
- For lubrication, the engine uses two-stroke engine oil, which is added to the fuel.

The engine design is combined with two-stroke engine oil with a mixing ratio of 40:1 to protect the environment.

## PAY ATTENTION

- When preparing oil mixing, first mix all the engine oil with half of the required fuel in the approved container. The container shall meet or exceed all local regulations. Then add the remaining fuel.
- Shake and mix the oil thoroughly before pouring it into the machine fuel tank.
- To ensure safe operation, do not add the specified oil to the engine. That will only produce more combustion residue, pollute the environment, and block the discharge channels of cylinders and silencers.



## ■ REFUELING

- Stop the engine when refueling, keep away from open flames, and no smoking.
- Do not spill fuel on the engine. If fuel is spilled, wipe it up.
- If fuel is spilled on clothing, change clothing immediately (to prevent clothing from catching fire).
- Carefully tighten the fuel tank cap. Start the engine in a different place (at least 3 meters away from the place where the fuel is added).
- Never refuel in an enclosed space. Fuel vapors accumulate on the ground (Explosion hazard).
- Make sure that children do not have access to stored fuel.
- Unscrew the fuel tank cap and fill the tank with fuel. Use a mesh funnel to filter the fuel.
- Tighten the fuel tank cap (hand only).
- Clean the screw plug and the area around the tank after refueling.
- Always erase spilled fuel to prevent fire.

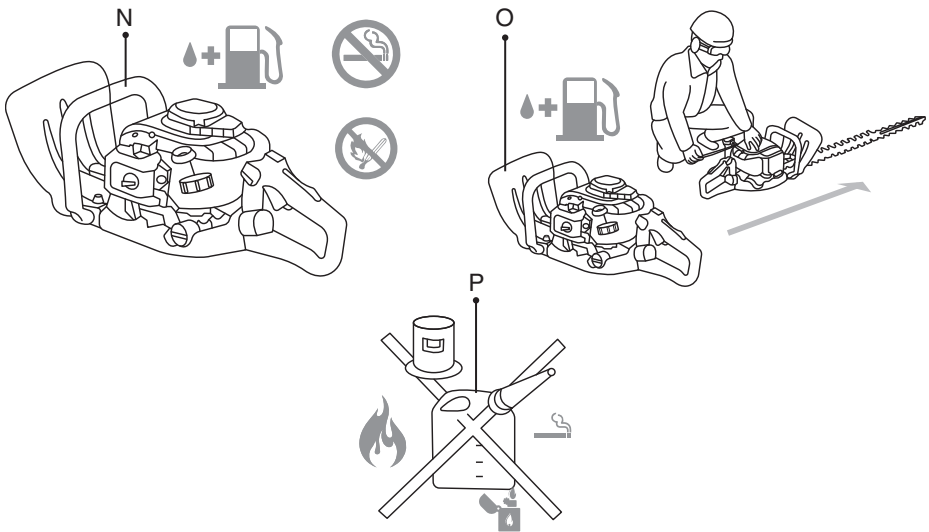

## ■ STORE FUEL

- Fuel oil cannot be stored indefinitely.
- Only purchase the amount of oil required for the 4-week operation period.

- Fuel can only be stored in approved containers.
- Make sure no children or other personnel are working at 15mm Pay special attention to the animals near the work area.
- Always check the operation safety of the hedge machine: check that the blade is damaged, whether the control lever is easy to operate, and whether the I-O switch is properly functional.
- Make sure that the blade is not running with the engine idling.
- If doubtful, please consult the dealer about the adjustments. Check that the handle is clean and dry and test the function of the I-O switch.
- The hedge machine can be started only as directed. Do not use any other method to start the engine! (See Startup)
- The engine can only be started after the complete assembly. Engine operation is allowed only after installing all suitable accessories. Otherwise, there is a danger of injury.
- Electric shock. Notice all of the wires and hedges. Before cutting, check the wires in all areas.

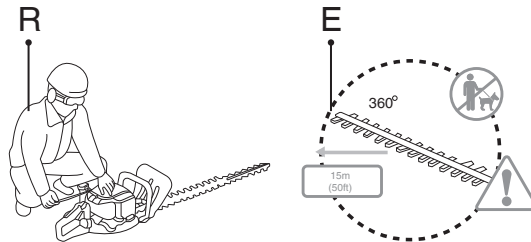

At least 3 meters away from the refueling position. Place the hedge machine on a clean floor. Make sure that the blade does not touch the ground or any other items. Cold start: (when the engine cooled or stops for more than 15 minutes or when fuel has been added to the engine.)

- 1) Push the I-O switch to the "I" position.
- 2) Push the oil bubble repeatedly (7 to 10 times) until the fuel enters the oil bubble.
- 3) Push the air valve switch to the "⌂" position.
- 4) Hold the machine down to avoid out of control when starting the engine. Failure to do so may cause serious personal injury or property

loss from contact with the blade.

5) Slowly pull the starter handle 10 to 15cm until resistance is felt.

6) Pull the starter handle and feel resistance to start the engine.

7) Turn the dam switch when the engine starts, stops, or places it in "IϕI"

8) Add to full speed and run the engine for about 1 minute at medium speed.

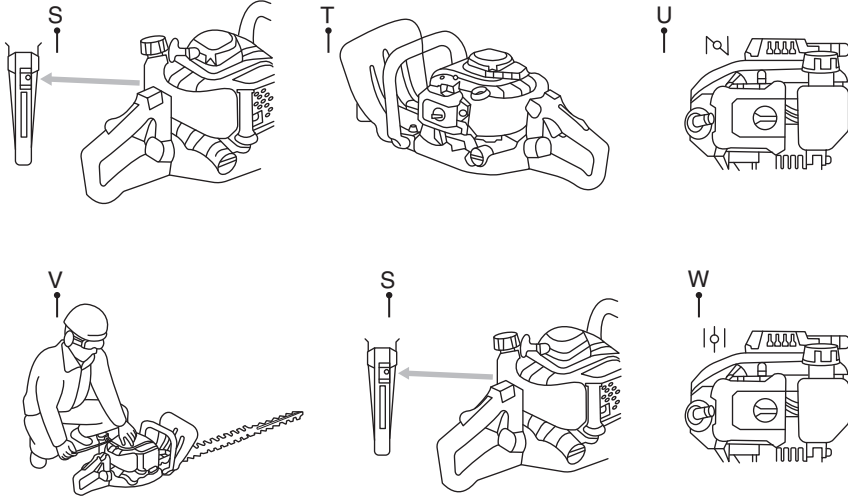

Body rebound refers to the high-speed rotating blade in the stone, trees, concrete, piles, pillars, and other hard fixed objects, because of the reverse force, the body in a moment of violent shaking phenomenon. When the rebound occurs, the body will suddenly appear in a W unexpected vibration, which may cause the operator to be unable to operate normally.

To prevent a rebound, observe the following:

- Be careful not to expose the blade to hard objects, posts, wire, and rock to avoid damage to the blade.
- When working, always shake hands and do not hold other parts.
- When working, keep your eyes on the blade. When you need to leave the blade, release the throttle trigger and return to the start speed position (when the blade stops in motion).
- Do not raise the blade close to your feet or just above the waist.

## STOP THE MACHINE

- Release the throttle trigger completely.
- Push the I-O switch (1) to the "O" position. The engine will slow down and stop.

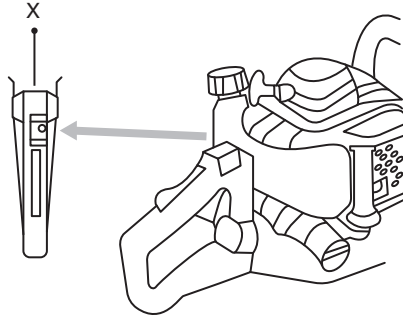

### ■ OPERATION HEDGE

- Do not operate the hedge trimmer machine during a light grip.
- Never contact the blade when the engine is starting or operating.
- Avoid suction gases when operating the hedge machine. Cannot operate the engine in a closed space (at risk of gas poisoning). Carbon monoxide gas is tasteless.
- All protective facilities, such as guards, must be used during operation.
- Do not operate the engine if the muffler is faulty or missing.
- Use a machine only with good light and visibility.
- In winter, pay more attention to slippery areas, snow, and ice, etc. (at risk of slipping). Always stand firm body.
- Do not stand on the ladder and operate the hedge machine. Let all your feet stand on the ground.
- Do not climb to the tree to use the hedge machine.
- Remove sand, nails, wires, etc. External objects may damage the blade.
- Cut branches 8 mm or thicker before cutting.
- The blade must reach full speed before starting the cutting.
- Always hold your hands firmly on the handle of the hedge machine.
- Form a firm grip with your thumb and other fingers around the handle.

- It takes time to stop after the throttle trigger is released.
- Do not operate the hedge machine at high speed. If the idling speed is too high, the cutting speed cannot be adjusted by the throttle control.
- When cutting, hold the hedge machine and let the blade form a 15-30° angle with the cutting line.
- Pay special attention when the cut hedges are close to or against the barbed wire.
- If the blade touches a rock or other hard object, turn off the engine and check the blade. Replace the damaged blade before reoperation.
- Take regular breaks. A 10-to-20-minute break is recommended for every 50 minutes of use.
- Also check that the carburetor and fuel / engine oil ratio are set correctly.

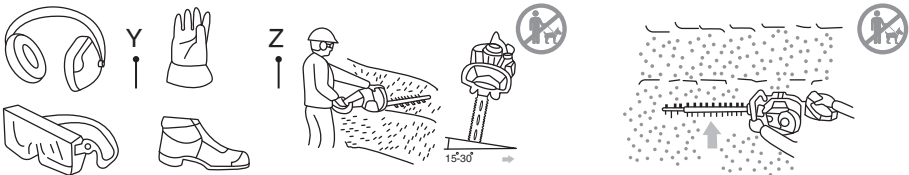

## ■ ADJUST THE REAR HANDLE ANGLE

The rear handle can turn left or right for 90° and each set at 45°.

- Press the release lever to release the lock.
- Turn the handle to an angle of 0°, 45°, or 90°.
- Make sure that the release lever returns to the initial position to engage and lock.
- Do not pull the throttle trigger when releasing the lock.
- Do not release the lock while working.

## MAINTENANCE INSTRUCTION

- Shut off the engine and remove the spark plug cap before cleaning / replacing / grinding the blade or performing any maintenance.
- Do not straighten or weld the damaged blades.
- Check the damage to the blade frequently (under engine shutdown).

- Keep the blade sharp.
- Clean the hedge machine regularly and check the tightening of all screws and nuts.
- Never repair hedge machines near open fires to prevent fires.
- Cortical gloves are always worn when holding or polished due to the sharp blade.

## ■ GRISHIN BLADE

If the blade edge becomes blunt and does not cut very well, polish the shadows in the picture component. The contact surface (sliding surface) of the top and bottom edge edges shall not be polished.

- Before grinding, hold the blade firmly, close the engine and remove the spark plug cap.
- Wear gloves, goggles, etc.
- Don't polish too much material. That would lose hardness and the blade would become blunt.

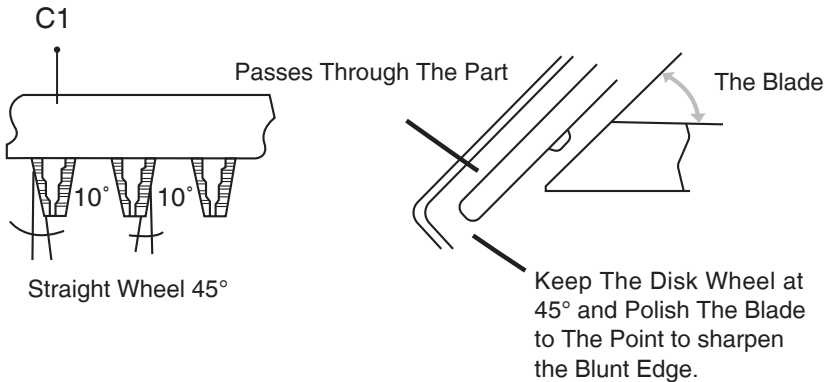

## ADJUST THE BLADE SPACING

Upper / lower blade wear. If the blade does not cut well even if it is sharp, adjust the spacing as follows.

- 1- Release the screw and remove the extension blunt teeth.
- 2- Release the nut (1) using the box or open wrench.
- 3- Gently tighten the truss bolt (2) with a hexagon wrench until it stops and turn a quarter circle.
- 4- Tighten the nuts (1) and secure the truss bolts (2).
- 5- Apply light oil on the friction surface of the blade.
- 6- Start the engine, open and close the throttle trigger for one minute.
- 7- Measure the time required for the blade to stop after releasing the throttle trigger. If it is two seconds or more, stop the engine and repeat steps 2 through 7.
- 8- Stop the engine and touch the blade surface. If they are not quite too hot, you can touch them, it means that it has been adjusted. If hot to touch, rotate the truss bolts (2) and repeat steps 6 to 8.
- 9- Tighten the screw and install the blunt teeth.

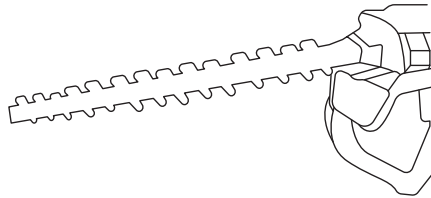
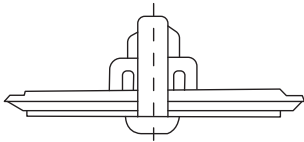

### **! PAY ATTENTION**

- Before adjusting, stop the engine and wait for the blade to stop. The blade has a slot next to the screw. If dust is found at the end of the groove, clean it.
- Check and adjust the idling speed.
- The blade should not run when the engine is idling.
- The idling speed shall be set at 3000r/min (rpm).
- If required, adjust the idling screw (the blade does not operate when the engine is idling).
- Blade running while idling-Turn the idling screw counterclockwise to reduce the idling speed.
- Engine stops while idling-Turn the idling screw clockwise to increase

the idling speed.

- The clutch shall be engaged at 4000 r/min (rpm) or higher.
- Check for the normal operation of the I-O switch, lock lever, and throttle trigger.

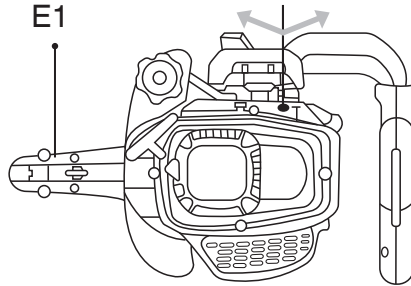

## CLEAN THE EMPTY FILTER

### **⚠ DANGER : FLAMMABLE**

- Check and clean the air filter once daily or every 10 working hours.
- Turn the damper switch to the full-off position and close the carburetor to avoid entering dust or dirt.
- Release the empty filter lock mother.
- Pull out the tail of the empty filter and move forward to remove it.
- If oil is stuck to the filter element (sponge), apply force cleaning.

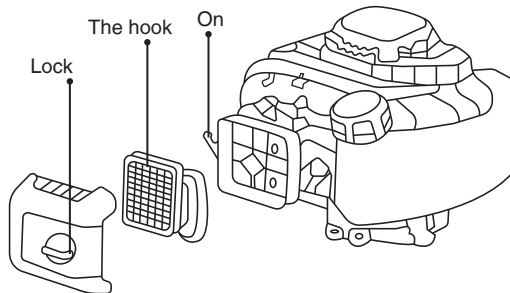



## ■ FOR HEAVY POLLUTION

- Remove the filter element (sponge), dip the element in warm water or water-diluted neutral detergent, and dry it thoroughly.
- Clean the filter element (linoleum) with gasoline and dry it thoroughly.
- Make sure that the filter element is fully dried before installing it. Insufficient dry filter elements may be difficult to start.
- Wipe the oil from the empty filter with a waste cloth.
- After cleaning, install the empty filter cover immediately and secure it with the retaining bolts. (When reinstalling, install the grab hook first).

## IMPORTANT MATTERS HANDLING EMPTY FILTER ELEMENTS

- If the dust is particularly high on the filter element, it should be cleaned multiple times a day.
- If the operation continues without removing the oil from the filter element, the oil in the empty filter may fall outside, causing oil contamination.
- Check the spark plug.
- Check and clean the spark plugs daily or every 8 working hours.
- The spacing between the two electrodes of the spark plug shall be 0.5-0.7 mm. If the spacing is too wide or too narrow, adjust. If the spark plugs are carbon-blocked or contaminated, they should be thoroughly cleaned or replaced. Make an accurate replacement.

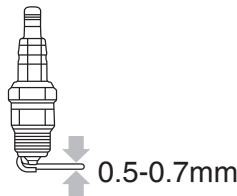

## ■ RUBRICATING OIL AND LUBRICANT

Grease was replenished by using the oil injection port every 50 working hours

**⚠ ATTENTION!**

Be sure to follow the specified time and grease supplement amount. Otherwise, an inadequate supply of grease will cause a mechanical failure. Clean the oil filter (the fuel filter in the oil tank).

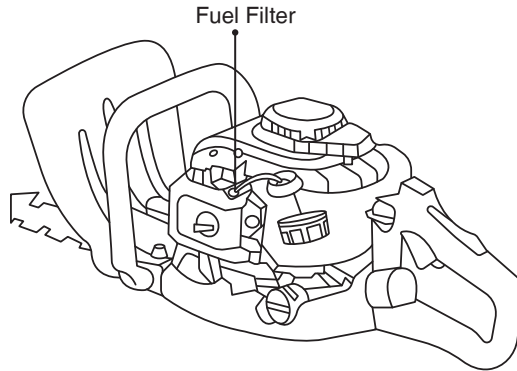

**■ WARN**

- Flammable products are strictly prohibited.
- Check and clean the fuel filter once daily or every 50 working hours.
- Fuel filter is used to filter the fuel required for the carburetor. Visually check the fuel filter regularly.
- When checking the fuel-filter, open the tank cap and hook the fuel-filter from the tank hole.
- Change the fuel-filter if it becomes hard, contaminated, or blocked. Change the fuel filter at least once a quarter to ensure adequate oil supply to the carburetor. An inadequate oil supply can cause an engine to start fail and limit the maximum speed.

**■ AFTER USE**

- Clean the exterior of the gasoline hedge machine and check for damage.
- Clean the air filters. When operating in dusty environments, clean the filters multiple times a day.
- Check the damage to the blades and make sure they are firmly installed.

## STORAGE

- When storing the machine for a long time, empty the gasoline in the tank and carburetor as follows: empty all the gasoline in the tank.
- Remove the spark plug and drop a few drops of engine oil into the spark plug hole. Then, gently pull the starter to spread the oil film throughout the engine and tighten the spark plug.
- Clean the dust and dirt outside the blades and engine, wipe them off with an oil soaked cotton cloth, and place the machine as dry as possible.

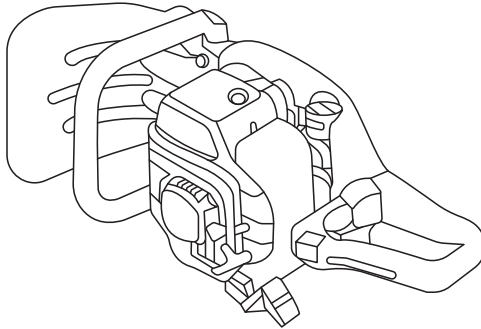



[www.ronixtools.com](http://www.ronixtools.com)