

# Ronix<sup>®</sup>

Premium Quality

## CIRCULAR SAW

### 4320

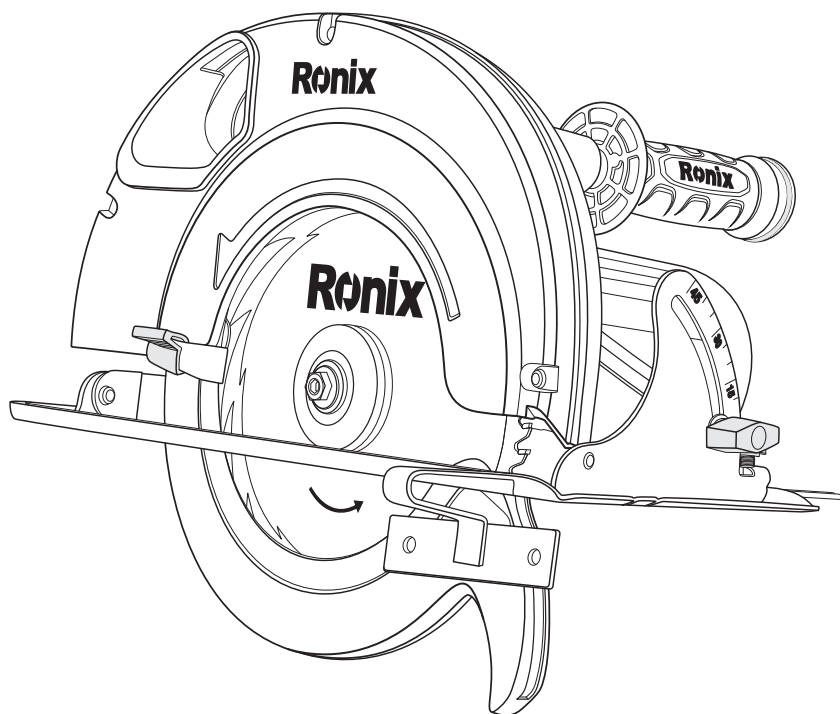

[www.ronixtools.com](http://www.ronixtools.com)

## SPECIFICATION

Model	4320
Power	2000W
Voltage	220V
Frequency	50-60Hz
Weight	6kg
No Loads of Speed	4200 RPM
Max Cutting Depth at 90°	85mm
Max Cutting Depth at °45	58mm
Saw Blade Diameter	235mm
Supplied In	Ronix color box
Includes	Guide rule, Ronix-design side handle, 2 pieces adjustable blade rings, Hex wrench, 235×2.4×30mm, 56T circular saw blade

## PART LIST

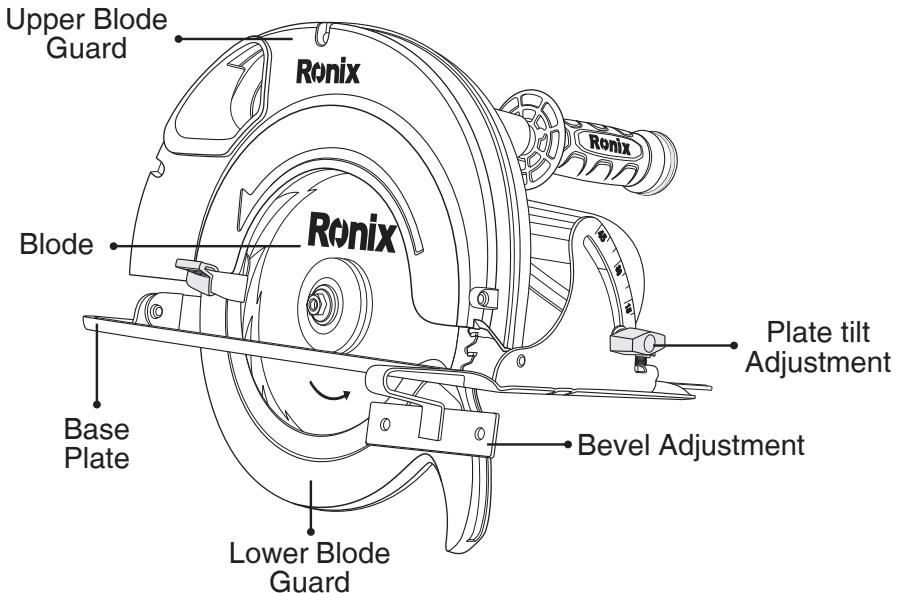

## GENERAL SAFETY RULES (FOR ALL TOOLS)

### **WARNING!**

Read and understand all instructions. Failure to follow all instructions listed below, may result in electric shock, fire and / or serious personal injury.

## SAVE THESE INSTRUCTIONS

### ■ **WORK AREA**

1. keep your work area clean and well lit.

Cluttered benches and dark areas invite accidents.

2. Do not operate power tools in explosive atmospheres, such as in the presence of flammable liquids, gases or dust. Power tools create sparks which may ignite the dust or fumes.

3. Keep bystanders, children and visitors away while operating a power tool. Distractions can cause you to lose control.

## ELECTRICAL SAFETY

4. Power tool plugs must match the outlet. Never modify the plugs in any way. Do not use any adapter plugs with earthed power tools. Unmodified plugs and matching outlets will reduce risk of electric shock. Do not change the plug in any way. Double insulation eliminates the need for the three wire grounded power cord and grounded power supply system.

5. Avoid body contact with grounded surfaces such as pipes, radiators, ranges and refrigerators. There is an increased risk of electric shock if your body is grounded.

6. Do not expose power tools to rain or wet conditions. Water entering a power tool will increase the risk of electric shock.

7. Do not abuse the cord. Never use the cord to carry the tools or pull the plug from an outlet. Keep cord away from heat, oil, sharp edges or moving parts. Replace damaged cords immediately. Damaged cords increase the

risk of electric shock.

8. When operating a power tool outside, use an outdoor extension cord marked “W-A” or “W”. These cords are rated for outdoor use and reduce the risk of electric shock.

## **PERSONAL SAFETY**

9. Stay alert, watch what you are doing and use common sense when operating a power tool. Do not use tool while tired or under the influence of drugs, alcohol, or medication. A moment of inattention while operating power tools may result in serious personal injury.

10. Dress properly. Do not wear loose clothing or jewelry. Contain long hair. Keep your hair, clothing, and gloves away from moving parts. Loose clothes, jewelry, or long hair can be caught in moving parts.

11. Avoid accidental starting. Be sure switch is off before plugging in. Carrying tools with your finger on the switch or plugging in tools that have the switch on invites accidents.

12. Remove adjusting keys or wrenches before turning the tool on. A wrench or a key that is left attached to a rotating part of the tool may result in personal injury.

13. Do not overreach. Keep proper footing and balance at all times. Proper footing and balance enables better control of the tool in unexpected situations.

14. Use safety equipment. Always wear eye protection. Dust mask, non-skid safety shoes, hard hat, or hearing protection must be used for appropriate conditions. Ordinary eye or sun glasses are NOT eye protection.

## **TOOL USE AND CARE**

15. Use clamps or other practical way to secure and support the workpiece to a stable platform. Holding the work by hand or against your body is unstable and may lead to loss of control.

16. Do not force tool. Use the correct tool for your application. The correct tool will do the job better and safer at the rate for which it is designed

17. Do not use tool if switch does not turn it on or off. Any tool that cannot

be controlled With the switch is dangerous and must be repaired.

18. Disconnect the plug from the power source before making any adjustments, changing accessories, or storing the tool. Such preventive safety measures reduce the risk of starting the tool accidentally.

19. Store idle tools out of reach of children and other untrained persons. Tools are dangerous n the hands of untrained users.

20. Maintain tools with care. Keep cutting tools sharp and clean. Properly maintained tools with sharp cutting edges are less likely to bind and are easier to control.

21. Check for misalignment or binding of moving parts, breakage of parts, and any other condition that may affect the tools operation. If damaged, have the tool serviced before using. Many accidents are caused by poorly maintained tools.

22. Use only accessories that are recommended by the manufacturer for your model. Accessories that may be suitable for one tool, may become hazardous when used on another tool.

## **SERVICE**

23. Tool service must be performed only by qualified repair personnel. Service or maintenance performed by unqualified personnel could result in a risk of injury.

24. When servicing a tool, use only identical replacement parts. Follow instructions in the Maintenance section of the manual. Use of unauthorized parts or failure to follow Maintenance instructions may create a risk of electric shock or injury.

## **SPECIFIC SAFTETY RULES**

DO NOT let comfort or familiarity with product (gained from repeated use ) replace strict adherence to circular saw safety rules. If you use this tool unsafely or incorrectly, you can suffer serious personal injury.

1. **DANGER!** Keep hands away from cutting area and blade. Keep your

second hand on auxiliary handle, or motor housing. If both hands are holding the saw, cannot be cut by the blade. Keep your body positioned to either side of the saw blade, but not in line with the saw blade. KICKBACK could cause the saw to jump backwards.

Do not reach underneath the work. The guard can not protect you from the blade below the work. Do not attempt to remove cut material when blade is moving.

 **CAUTION:**

- Blades coast after turn off. Wait until blade stops before grasping cut material.
2. Check lower guard for proper closing before each use. Do not operate saw if lower guard does not move freely and close instantly. Never clamp or tie the lower guard into the open position. If saw is accidentally dropped, lower guard may be bent. Raise the lower guard with the retracting Lever and make sure it moves freely and does not touch the blade or any other part, in all angles and depths of cut. To check lower guard, open lower guard by hand, then release and watch guard closure. Also check to see that retracting Lever does not touch tool housing. Leaving blade exposed is **VERY DANGEROUS** and can lead to serious personal injury.
  3. Check the operation and condition of the lower guard spring. If the guard and the spring are not operating properly, they must be serviced before use. Lower guard may operate sluggishly due to damaged parts, gummy deposits, or a buildup of debris.
  4. Lower guard should be retracted manually only for special cuts such as “Pocket Cuts” and “Compound Cuts.” Raise lower guard by retracting Lever. As soon as blade enters the material, lower guard must be released. For all other sawing, the lower guard should operate automatically.
  5. Always observe that the lower guard is covering the blade before placing saw down on bench or floor. An unprotected, coasting blade will cause the saw to walk backwards, cutting whatever is in its path. Be aware of the time it takes for the blade to stop after switch is released.
  6. **NEVER** hold piece being cut in your hands or across your leg. It is important to support the work properly to minimize body exposure, blade bind-

ing, or loss of control.

7. Hold tool by insulated gripping surfaces when performing an operation where the cutting tool may contact hidden wiring or its own cord. Contact with a “live” wire will also make exposed metal parts of the tool “live” and shock the operator.

8. When ripping always use a rip fence or straight edge guide. This improves the accuracy of cut and reduces the chance for blade binding.

9. Always use blades with correct size and shape (diamond vs. round) arbor holes. Blades that do not match the mounting hardware of the saw will run eccentrically, causing loss of control.

10. Never use damaged or incorrect blade washers or bolts. The blade washers and bolt were specially designed for your saw, for optimum performance and safety of operation

11. Causes and Operator Prevention of Kickback: Kickback is a sudden reaction to a pinched or bound or misaligned saw blade, causing an uncontrolled saw to lift up and out of the Workpiece toward the operator. When the blade is pinched or bound tightly by the kerf closing down, the blade stalls and the motor reaction drives the unit rapidly back toward the operator. If the blade becomes twisted or misaligned in the cut, the teeth at the back edge of the blade can dig into the top surface of the wood causing the blade to climb out of the kerf and jump back toward operator. Kickback is the result of tool misuse and/or incorrect operating procedures or conditions and can be avoided by taking proper precautions as given below: Maintain a firm grip with both hands on the saw and position your body and arm to allow you to resist KICKBACK forces. KICKBACK forces can be controlled by the operator, if proper precautions are taken. When blade is binding, or when interrupting a cut for any reason, release the trigger and hold the saw motionless in the material until the blade comes to a complete stop. Never attempt to remove the saw from the work or pull the saw backward while the blade is in motion or KICKBACK may occur. Investigate and take corrective actions to eliminate the cause of blade binding. When restarting a saw in the workpiece, center the saw blade in the kerf and check that saw teeth are not engaged into the material. If saw blade is binding, it may walk up or KICKBACK from

the workpiece as the saw is restarted. Support large panels to minimize the risk of blade pinching and KICKBACK. Large panels tend to sag under their own weight. Supports must be placed under the panel on both sides, near the line of cut and near the edge of the panel. To minimize the risk of blade pinching and kickback. When cutting operation requires the resting of the saw on the workpiece, the saw should be rested on the larger portion and the smaller piece cut off. To avoid kickback, do support board or panel near the cut. Do not support board or panel away from the cut. Do not use dull or damaged blade. Unsharpened or improperly set blades produce narrow kerf causing excessive friction, blade binding and KICKBACK. Keep blade sharp and clean. Gum and wood pitch hardened on blades slows saw and increases potential for kickback. Keep blade clean by first removing it from tool, then cleaning it with gum and pitch remover, hot water or kerosene. Never use gasoline. Blade depth and bevel adjusting locking levers must be tight and secure before making cut. If blade adjustment shifts while cutting, it may cause binding and KICKBACK. Use extra caution when making a "Pocket Cut" into existing walls or other blind areas. The protruding blade may cut objects that can cause KICKBACK. For pocket cuts, retract lower guard using retracting Lever. ALWAYS hold the tool firmly with both hands. NEVER place your hand or fingers behind the saw. If kickback occurs, the saw could easily jump backwards over your hand, leading to serious personal injury. Never force the saw. Forcing the saw can cause uneven cuts, loss of accuracy, and possible kickback. Push the saw forward at a speed so that the blade cuts without slowing.

12. Use extra caution when cutting damp wood, pressure treated lumber, or wood containing knots. Adjust speed of cut to maintain smooth advancement of tool without decrease in blade speed.

13. Adjustments. Before cutting be sure depth and bevel adjustments are tight.

14. Avoid Cutting Nails. Inspect for and remove all nails from lumber before cutting.

15. When operating the saw, keep the cord away from the cutting area and position it so that it will not be caught on the workpiece during the cutting operation. The tool is provided with a front grip and rear handle for two hand operation. Operate with proper hand support, proper workpiece support,



and supply cord routing away from the work area. **WARNING:** It is important to support the workpiece properly and to hold the saw firmly to prevent loss of control which could cause personal injury. illustrates typical hand support of the saw. A typical illustration of proper hand support, workpiece support, and supply cord routing

16. Place the wider portion of the saw base on that part of the workpiece which is solidly supported, not on the section that will fall off when the cut is made. If the workpiece is short or small, clamp it down.

## **DO NOT TRY TO HOLD**

### **SHORT PIECES BY HAND!**

17. Never attempt to saw with the circular saw held upside down in a vise. This is extremely dangerous and can lead to serious accidents.

18. **WARNING:** Blade coasts to stop after switch is released. Contact with coasting blade can cause serious injury. Before setting the tool down after completing a cut, be sure that the lower (telescoping) guard has closed and the blade has come to a complete stop.

19. Some material contains chemicals which may be toxic. Take caution to prevent working dust inhalation and skin contact. Follow material supplier safety data.

## **SAVE THESE INSTRUCTIONS**

### **WARNING!**

**MISUSE** or failure to follow the safety rules stated in this instruction manual may cause serious personal injury.

**SYMBOLS** The following show the symbols used for the tool.

v	voltage
n	no load speed
A	amper
--/min	revolutions reciprocation per minute
Hz	hertz
	class II construction

## FUNCTIONAL DESCRIPTION

### ASSEMBLY

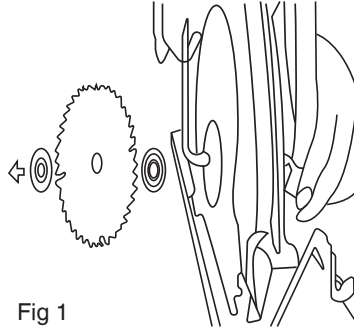

Fig 1

#### **⚠ CAUTION:**

- Always be sure that the tool is switched off and unplugged before carrying out any work on the tool.

### REMOVING OR INSTALLING SAW BLADE

#### **⚠ CAUTION:**

- Be sure the blade is installed with teeth pointing up at the front of the tool.
  - Use only the Ronix wrench to install or remove the blade.
1. To remove the blade, Press the Lock shaft so that it cannot revolve, then use the Hex wrench to loosen the hex bolt counterclockwise. Then remove the hex bolt, outer flange and blade.( Fig1)
  2. To install the blade, follow the removal procedure in reverse.

#### **■ BE SURE TO TIGHTEN THE HEX BOLT CLOCKWISE EQUALLY**

Main Component

- 1) Inner Flange
- 2) Saw Blade
- 3) Outer Flange
- 4) Hex Wrench

Notice: When changing blade, make sure to also clean upper and lower blade guards of accumulated sawdust. Such efforts do not, however, replace the need to check lower guard operation before each use.

Adjusting Bevel cutting Loosen the clamping screw on the bevel scale plate on the front of the base. Set for the desired angle (0°-45°) by tilting accordingly, then tighten the clamping screw securely.(Fig2)

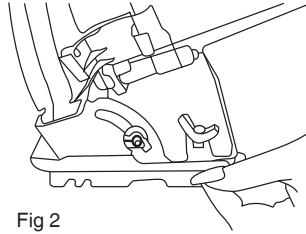

Fig 2

## ADJUSTING DEPTH OF CUT

### CAUTION:

- After adjusting the depth of cut, always tighten the clamping screw securely. Loosen the clamping screw on the depth guide and move the base up or down. At the desired depth of cut, secure the base by tightening the clamping screw.

1. Loosen the clamping screw on the depth guide and move the base up or down. At the desired depth of cut, secure the base by tightening the clamping screw.(Fig 3) For cleanser, safer cuts, set cut depth so that no more than a blade tooth length projects below workpiece surface. Using proper cut depth helps to reduce potential for dangerous KICKBACKS which can cause personal injury.

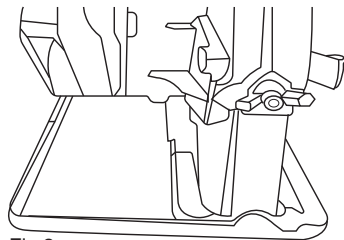

Fig 3

## SAW SIGHTING(FIG4)

For straight cuts, align the Right groove on the front of the base plate with your cutting line, For 45°bevel cuts, align the Left groove with it.

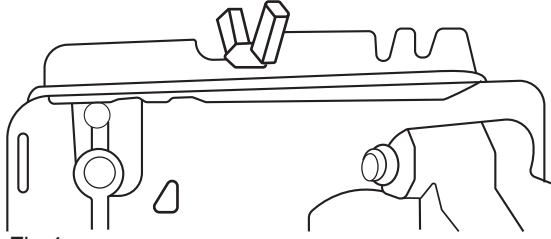

Fig 4

## SWITCH

### ⚠ CAUTION:

Before plugging in the tool, always double check the shaft lock in the “off” position. Press down the switch trigger to run, Release switch to stop. (Fig 5)

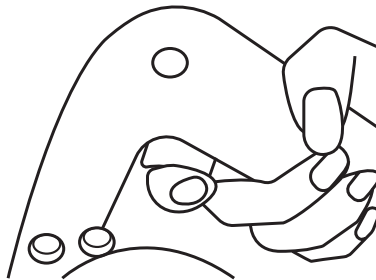
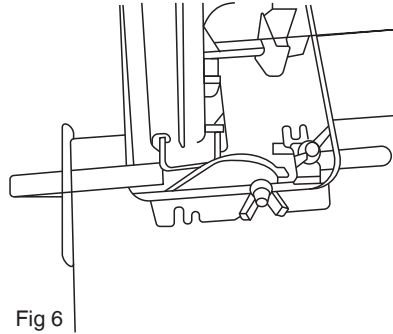

Fig 5

## RIP FENCE (GUIDE RULES)

The handy rip fence allows you to do extra-accurate straight cuts, simple slide the rip fence up snugly against the side of workpiece and secure it in position with screw of the front of base. It also makes repeated cuts of uniform width possible.(Fig.)



## EFFECTIVE AND SAFE FOR SAWING OPERATION

Always hold the tool firmly with one hand on housing and the other on the side handle, turn the tool on and then apply the blade to the workpiece.

1. Put the tool's Base plate on the workpiece, Let the blade don't touch the workpiece,you don't saw equably the workpiece until the machine get to the maximum speed from starting.
2. Should control the sawing speed for different material, and get to know should be pushed slowly when you saw the harder wood.

## MAINTENANCE & DAILY CARE

### CAUTION:

Always be sure that the tool is switch off and unplugging before attempting to perform inspection and maintenance.

1. The tool and its air vents have to be keep clean, regularly clean the tools air vents or whenever the vents start to become obstructed
2. Check the all screws if be loosened or not periodically.
3. Check the cord insulation if broken or not.

## REPLACING CARBON BRUSHES

1. Remove and check the carbon brushes regularly. Replace when the tool occur obvious sparks or wear down to the limit mark.

2. Both carbon brushes should be replaced at the same time. Use only Ronix brushes provided.
3. Use a screwdriver to remove the brush holder caps. Take out the worn carbon brushes, insert the new ones and secure the brush holder caps (Fig 7)

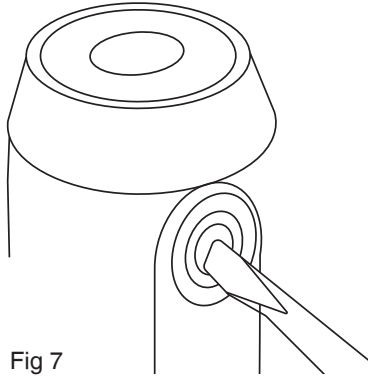
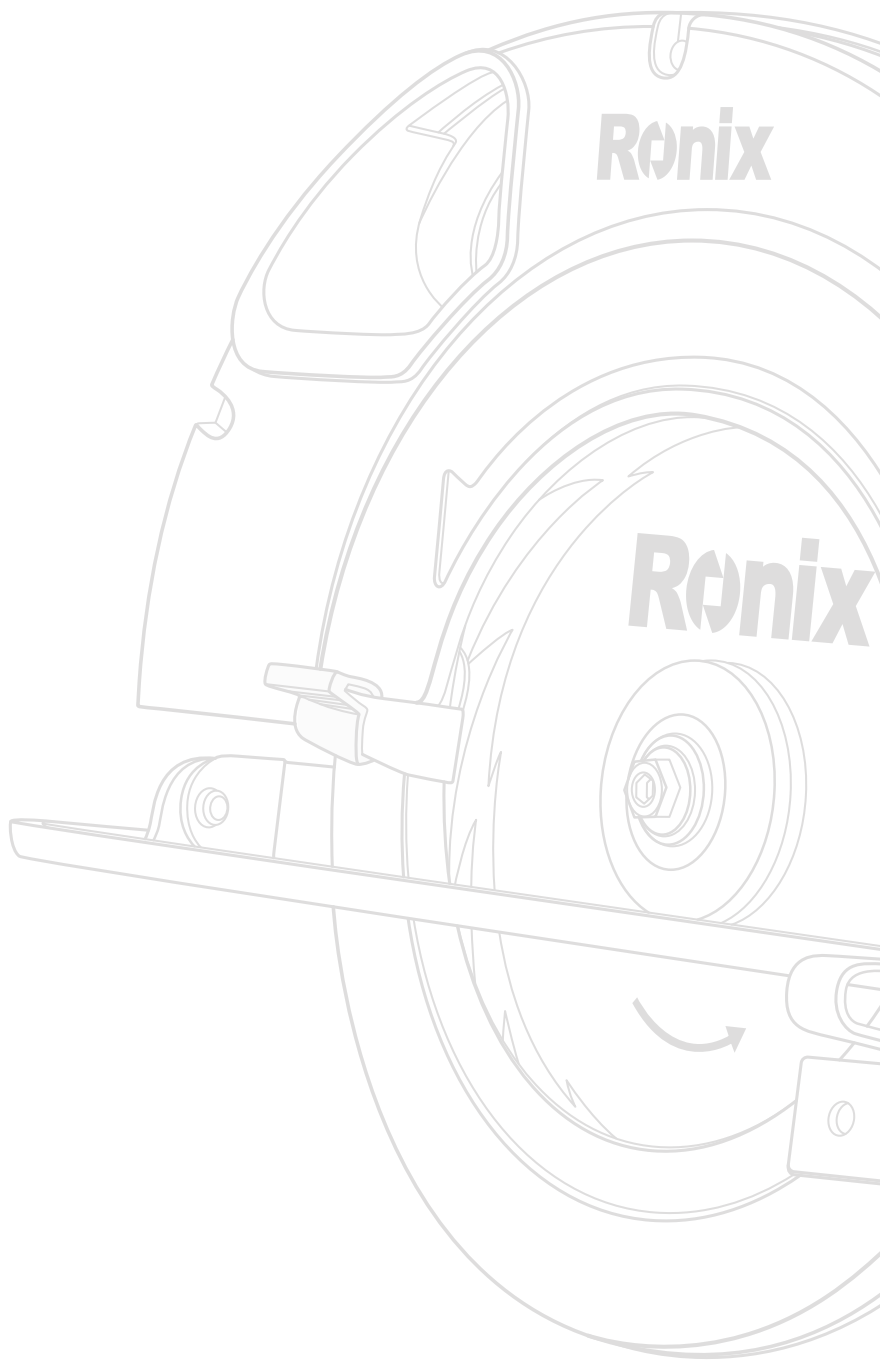

Fig 7

**⚠ CAUTION:**

Be sure to re-install the knob after inserting new carbon brush. After replacing brushes, plug in the tool and break in brushes by running tool with no load for about 10 minutes. Then check the tool while running, when releasing the switch trigger. If the tool is not working well, ask your local Ronix service center for repair.

To maintain product SAFETY and RELIABILITY, repairs, any other maintenance or adjustment should be performed by Ronix Authorized or Factory service centers, always using Ronix replacement parts.



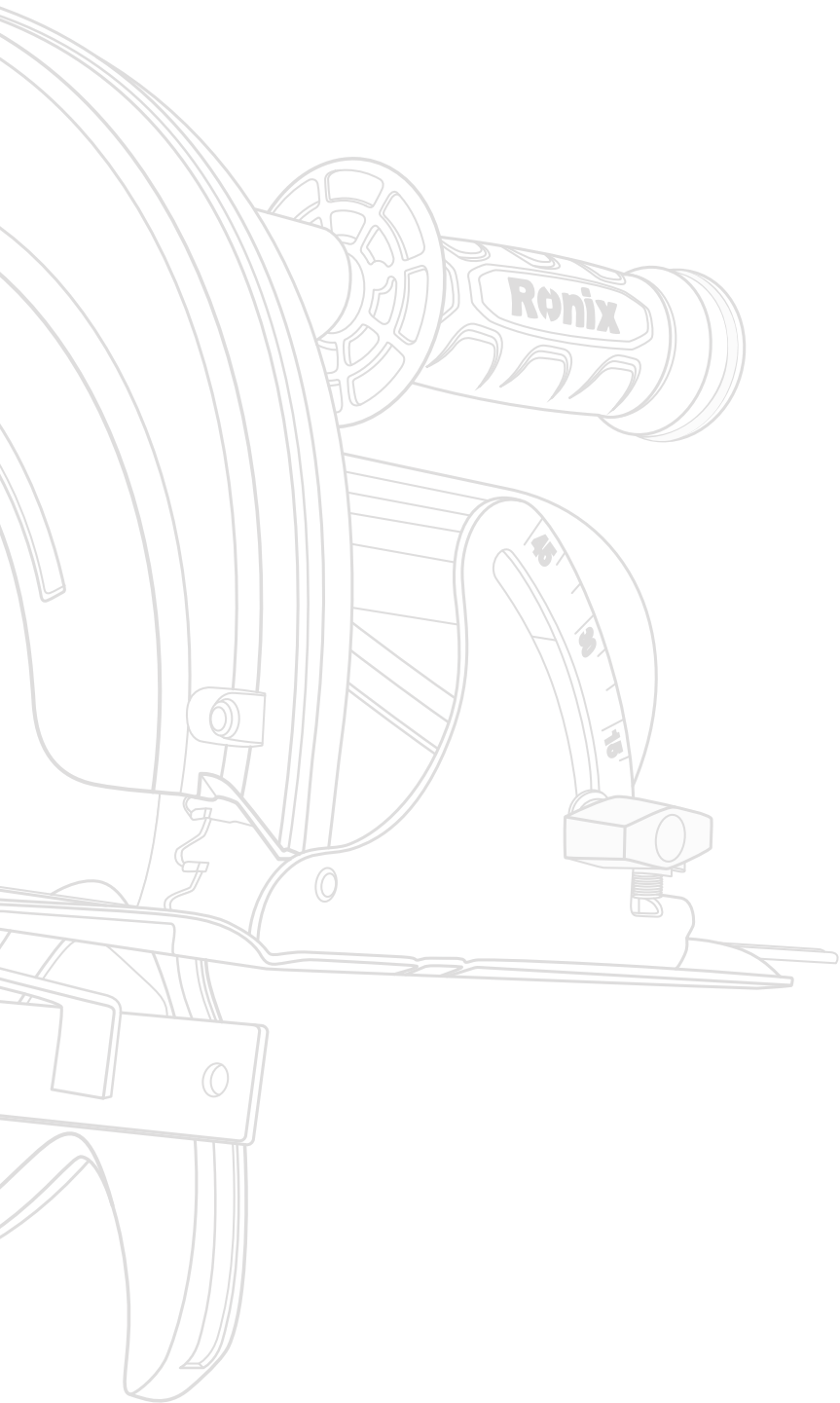



**Ronix**<sup>®</sup>  
Premium Quality