

Ronix[®]

Premium Quality

JIGSAW

4120

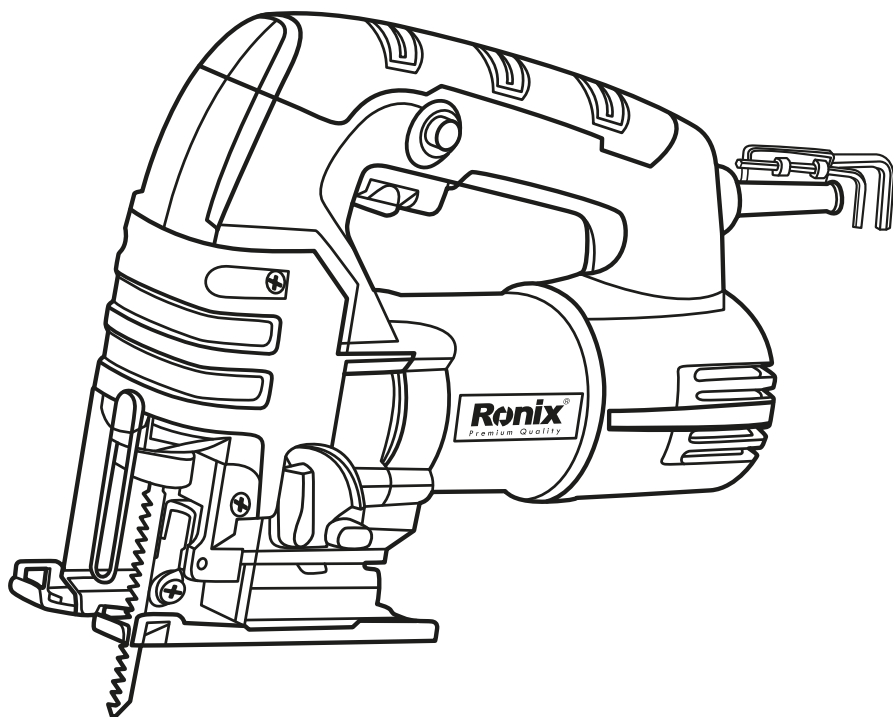

www.ronixtools.com

SPECIFICATIONS

Model	4120
Power	650W
Voltage	220V
Frequency	50Hz
Max Capacity in Wood	60mm
Max Capacity in Metal	10mm
Orbital Action	4-Position
Bevel Cutting Capacity	0-45Degree
No-load RPM	0-3100 RPM
Weight	2.75kg
Accessories	Hex Key 2pc , Wood Blade 2pc

PARTS LIST

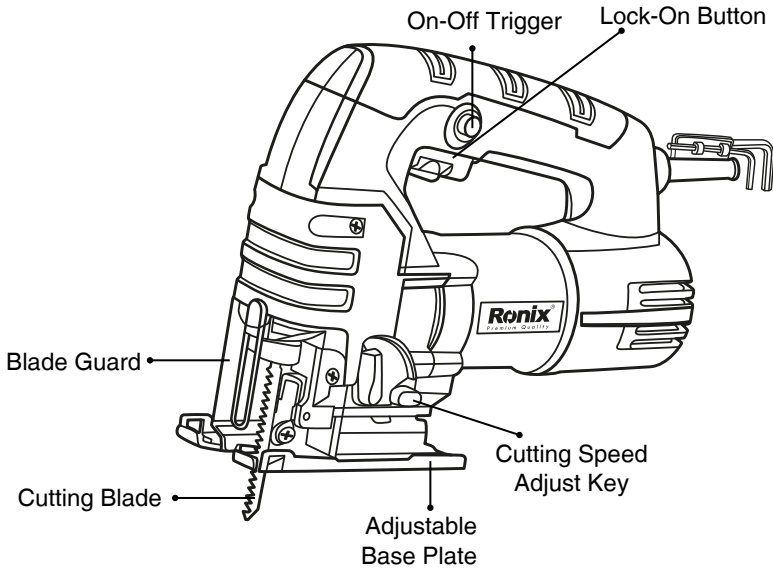

SAFETY INSTRUCTIONS

■ FOR YOUR SAFTY

Read all instructions. Failure to follow all instructions listed below may result in electric shock, fire and/or serious injury.

Additionally, the general safety instructions either in the enclosed booklet or those added in the center of these operating instructions must be observed.

SAVE THESE INSTUCTION.

- Secure the workplace. A workplace clamped with clamping devices or in a vice is held more secure than by hand.
- Do not work materials containing asbestos. Asbestos is considered carcinogenic.
- Always wait until the too; has come to a complete stop before placing it down. The tool insert can jam and lead to loss of control over the power tool.
- Do not use a power tool with a damaged power cord. Do not touch the damaged cord and pull the power plug when the cord is damaged while working. Damaged cords increase the risk of an electric shock.
- Connect power tools that are used in the open via a ground fault circuit interrupter.
- Keep hands away from the cutting area. Do not reach under the material being cut. Contact whit the saw blade may result in injury.
- Guide the tool against the workplace only when it is switched on. Otherwise there may be danger of kickback when the tool insert jams in the work place.
- Pay attention that the footplate rests securely on the material while sawing. A jammed saw blade can break or lead to kick back.
- After the cut, switch off the power tool and wait until the saw

blade has come to a stop before pulling it out of the cut. This avoids kickback and the tool can be placed down securely.

- Use only undamaged blades that are in proper condition. Bent or dull saw blades can break or cause kickback.
- After switching off, do not (brake) the saw blade by applying sideward pressure against it. The saw blade can become damaged, break or cause kickback.
- Use appropriate detectors to determine if utility lines are hidden in the work area or call the local utility company for assistance.

⚠ CAUTION:

Always be sure that the tool is switched off and unplugged before cutting out any work on the tool.

■ INSTALLING OR REMOVING SAW BLADE

⚠ CAUTION:

Always clean out all chips or foreign matter adhering to the blade and/or blade holder. Failure to do so may cause insufficient tightening of the blade, resulting in a serious personal injury.

Do not touch the blade or the workplace immediately after operation; they may be extremely hot and could burn your skin. Always secure the family. Insufficient tightening of the blade may cause blade breakage or serious personal injury.

To install the blade, loosen the bolt counterclockwise on the blade holder with the hex wrench. With the blade teeth facing forward, insert the blade into the blade holder as far as it will go. Make sure that the back edge of the blade fits in to the roller. Then tighten the bolt clockwise to secure the blade. To remove the blade, follow the installation procedure in reverse.

▲ NOTE:

Occasionally lubricate the roller.

■ HEX WRENCH STORAGE

When not in use, store the hex wrench as shown in the figure to keep it from being lost.

■ ANTI-SPLINTERING DEVICE

For splinter-free cuts, the anti-splintering device can be used. To install the anti-splintering device, move the base all the way forward and insert it between the two protrusions of the base.

▲ NOTE:

The anti-splintering device cannot be used when making bevel cuts.

OPERATION

▲ CAUTION:

Always hold the base flush with the workplace. Failure to do so may cause blade breakage, resulting in a serious injury. Advance the tool very slowly when cutting curves or scrolling.

Forcing the tool may cause a slanted cutting surface and blade breakage. Turn the tool on without the blade making any contact and wait until the blade attains full speed. Then rest the base flat on the workplace and gently move the tool forward along the previously marked cutting line.

■ BEVEL CUTTING

▲ CAUTION:

Always be sure that the tool is switched off and unplugged before

tilting the base. Raise the dust cover all the way before making bevel cuts.

With the base titled, you can make bevel cuts at any angle between 0° and 45° (left or right). Loosen the bolt on the back of the base with the hex wrench. Move the base so that the bolt is positioned in the center of the cross-shaped slot in the base.

■ FRONT FLUSH CUTS

Loosen the bolt on the back of the base with the hex wrench and slide the base all the way back. Then tighten the bolt to secure the base.

■ CUT OUT

Cutouts can be made with either of two methods A or B.

A) Boring a starting hole

For internal cutouts without a lead-in cut from an edge, pre-drill a starting hole 12 mm (1/2 in) or more in diameter. Insert the blade into this hole to start your cut.

B) Plunge cutting

You need not bore a starting hole or make a lead-in if you carefully do as follows.

1) Tilt the tool up on the front edge of the base with the blade point positioned just above the workplace surface.

2) Apply pressure to the tool so that the front edge of the base will not move when you switch on the tool and gently lower the back end of the tool slowly.

3) As the blade pierces the workplace, slowly lower the base of the tool down into the workplace surface.

4) Complete the cut in the normal manner.

■ FINISHING EDGES

To trim edges or make dimensional adjustment, run the blade lightly along cut edges.

■ METAL CUTTING

Always use a suitable coolant (cutting oil) when cutting metal. Failure to do so will cause significant blade wear. The underside of the workplace can be greased instead of using a coolant.

MAINTENANCE

CAUTION:

Always be sure that the tool is switched off and unplugged before attempting to perform inspection or maintenance. To maintain product SAFETY and RELIABILITY, repairs, carbon brush inspection and replacement.

■ ENVIRONMENTAL PROTECTION

Recycle raw materials instead of disposing them as waste the power tool, its accessories and packaging materials should be sorted for environmentally-friendly recycling.

CAUTION:

Wear hearing protection!

The typical hand-arm vibration is below 2.5 m/s².

Ronix[®]
Premium Quality

www.ronixtools.com