

Ronix®

Premium Quality

JIG SAW 4110

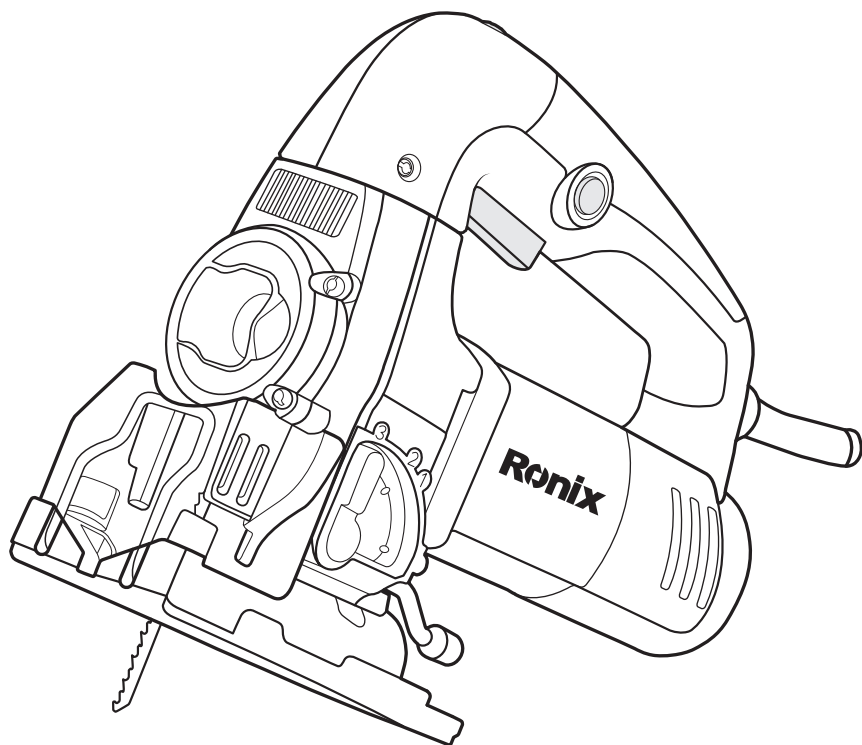

www.ronixtools.com

12
MONTHS
GUARANTY

FREE
DELIVERY

BANK
SPARE PARTS

CALL
CENTER
02161904

TECHNICAL SPECIFICATION

Cutting capacity	Wood: 130mm, Steel: 10mm
Voltage	220V
Frequency	50HZ
Rated power	600W
No- load speed	500-2500RPM
Net Weight	3.0kg

PART LIST

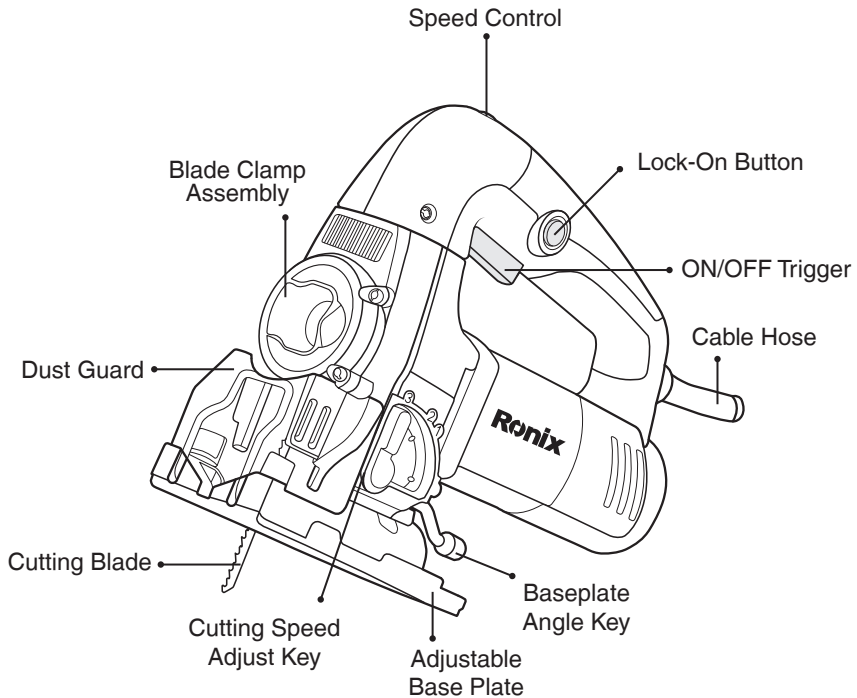

SAFETY INSTRUCTIONS

WARNING!

WHEN USING ELECTRIC TOOLS, ALL THE SAFETY INSTRUCTIONS SHOULD ALWAYS BE OBSERVED TO REDUCE THE RISK OF FIRE, ELECTRIC SHOCK AND PERSONAL INJURY BEFORE ATTEMPTING TO OPERATE THE TOOL, PLEASE READ ALL THE INSTRUCTIONS AND SAVE IT FOR FURTHER REFERENCE.

■ BASIC SAFETY PRECAUTIONS FOR ALL ELECTRIC TOOLS

1) Keep work area clean

Cluttered area and benches invite injuries.

2) Consider work area environment

Don't use electric tools in damp or wet locations. Don't expose electric tools to rain. Keep work area well, In particular, no inflammable liquids or gases must be present.

3) Avoid electric shock.

when you are operating tools, don't touch metal being grounded, such as pipe, radiator, freezer, etc.

4) Keep children and visitors away

Don't let children contact tool or extension cord. All visitors should be kept away from work place.

5) Store idle tool

when not in use, tools should be stored in dry, high, or locked - up place.

6) Don't force tool

It will do the job better and safer at the rate for which it was intended, Avoid unnecessary overload which may put the operator at risk and impair functions of the tools.

7) Use right tool

Don't force small tools and attachment to do the job of a heavy duty tool. Don't use tools for purpose not intended, for example, don't use electric circular saw for cutting logs or tree limbs.

8) Dress properly

Don't wear loose clothes or jewelry. They can be caught in moving parts. Rubber gloves and non- skid footwear are recommended when working outdoors. Wear protective hair covering to contain long hair.

9) Use safety goggles

Always wear safety goggles. If dust is produced, use the special masks.

10) Don't abuse cables

Never carry tool by cable or yank it to disconnect it from socket. Keep cable from heat, oil and sharp edges.

11) Don't overreach

Keep proper footing and balance at all times.

12) Maintain tools with care

Keep tools sharp and clean for better and safer performance. Follow instructions for lubricating and changing accessories. Inspect tool cords periodically and replace if damaged. Keep handles dry, clean and free from oil and grease.

13) Disconnect tools

when not in use, before servicing, and when changing accessories such as blades, bits and cutters.

14) Remove adjusting keys wrenches

from the habit of checking to see that keys and adjusting wrenches are removed from tool before turning it on.

15) Avoid unintentional starting

Don't carry plugged - in tool with finger on switch. Make sure switch is off when connecting the plug to the socket.

16) Use extension cord

If an extension cord is required, always check that its cross- section measurement is equal to or greater than that of the tool capabilities and so marked.

17) Stay alert

Watch what you are doing. Use common sense. Do not operate tool when you are tired.

18) Check damaged parts

Before further use of the tool, a guard or other parts that is damaged

should be carefully checked to determine that it will operate properly and perform its intended function. Check for alignment of moving parts, binding of moving part, breakage of parts, mounting and any other condition that may affect its operations, A guard or other part that is damaged should be properly repaired or replaced by a qualified service center unless otherwise indicated elsewhere in the instruction manual. Have defective switches replaced by a qualified service center. Do not use tool if switch does not turn on and off.

19) Check the voltage

Do not plug the electric tool into the mains until you have checked that the voltage shown on the data plate corresponds to the voltage available.

20) Replace parts

The use of improper accessory or attachment other than recommended present a risk of personal injuries.

21) Have your tool repaired by an expert

This electric tool is in accordance with the relevant safety regulations. Repairing of electric tool may be carried out only by expert. Otherwise, it may cause considerable danger of the user.

■ JIG SAW USE

This jig saw is intended for the cutting of wood pieces, steel, aluminum, plastic with different types of cutting blade.

■ ADDITIONAL SAFETY REGULATIONS

- 1) BEFORE USING THE TOOL, PLEASE CHECK THE SWITCH IS OFF AND THE PLUG IS NOT CONNECTED TO ELECTRICITY SOCKET.
- 2) The tool should not touch any objects when turning on the tool to avoid any danger.
- 3) Before plug in the electricity socket, please make sure the machine is switched off and put the cable on back side.
- 4) Switch on the tool, then start cutting on work piece.
- 5) Don't touch the moving parts especially the blade.
- 6) Make sure there is no obstacle objective on work piece.

- 7) Hold the tools tightly when operating the tool.
- 8) Don't lay down the tool on the ground or working table before switch it off.
- 9) Don't cut the material with asbestos. When cutting some material like fiber, please wear mask.
- 10) When switch off the tool, don't stop the blade by pressing, Don't touch the blade by hand because it is quite hot when just stop working.
- 11) Only use sharp and indefective blade. The blade must be replaced if it is broken, with crack, distorted or blunt.
- 11) If the extended cord need, please use the same type of the tool.
- 12) If the working surrounding is too hot, damp or too much dust, please use an circuit- cut device to assure the safety of operator.

OPERATION REGULATIONS

■ FITTING AND REMOVING A SAW BLADE

▲ NOTE:

Prior to assembly and adjustment, always unplug the tool. This tool has SDS system for quick and easy changing of saw blade.

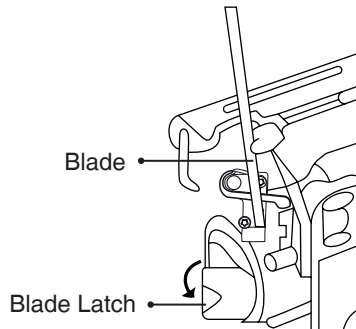

■ FITTING THE BLADE

- Open the blade holder by fully retracting the blade latch.
- Insert the saw blade into the blade holder, guiding the back of the

blade into the groove of the guide roller.

-Release the blade latch, the blade is assembled well.

■ REMOVING THE BLADE

- Release the blade latch, fully retract the blade latch and pull the blade out of the holder.

■ SAW BLADES INSTRUCTION

The blade is supplied with customers' requirement. The above blades may not be supplied with tool.

Blade type	Application
Fine- toothed cutting blade	For smooth straight cuts
Coarse - toothed cutting blade	For fast straight cuts
Metal cutting blade	For ferrous and non - ferrous metals
Flush cutting blade	For finishing off cuts up to a wall or edge

■ SETTING THE PENDULUM ACTION

The four pendulum action settings allow optimum adaptation of cutting speed, cutting capacity and cutting pattern to the material being sawed. The pendulum action can be adjusted in four steps with the adjustment lever. Switching is possible with the machine running:

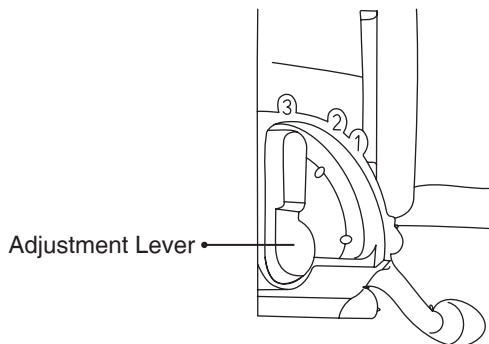

■SETTING THE BEVEL ANGLE

The adjustable shoe allows cutting of left hand or Right hand bevel angles from 0 -45°. The bevel scale has preset positions at 0° , 15° , 30° , 45°

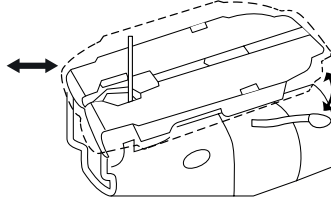

- RELEASE THE SHOE LEVEL.
- Slide the shoe toward the saw blade.
- Tilt the shoe and set the desired bevel angle by using the scale
- Tighten the shoe lever.

■SWITCHING ON AND OFF

Note: please make sure that the switch is off when the tool plug into electricity socket.

- 1) To run the tool, press the on/ off switch.
- 2) For continuous operation , press and hold down the switch, press the lock- on button and release the switch.
- 3) To stop the tool, release the switch.
- 4) To stop the tool in continuous operation, press the switch briefly and release it. Always switch off the tool when work is finished and before unplugging.

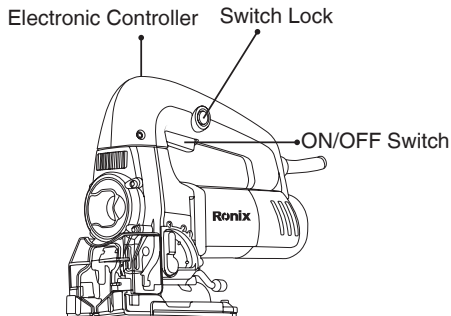

■SETTING THE ELECTRONIC SAWING SPEED

To preset the sawing speed, turn the control dial to the desired level. The higher the rate, the higher the sawing speed. The required setting depends on the thickness and kind of material.

Using high speeds for sawing soft materials such as wood, Use low speeds for sawing metal. Please refer to below information.

Working objective	Control dial level
Wood	5-6
Sheet steel	3-6
Stainless steel	3-4
Aluminum	2-3
Plastic	1-4

■EFFECTIVE AND SAFE CUTTING

NOTE:

Please lubricate the guide rather frequently.

- If necessary . draw a cutting line.

- Drill a hole (∅ Min.12mm) and introduce the saw blade.

Switch the tool on.

follow THE LINE WHEN CUTTING STRAIGHTLY.

.For pendulum cutting. Please move the tool slightly.

1)Sawing in metal

. Mount an appropriate saw blade.

.Proceed as described above.

.Use a cooling lubricant (cutting oil) to prevent overheating of the saw blade or the workpiece.

2) Mounting the plastic anti- scratch shoe cover.

When cutting some decoration material or plastic workpiece, please use the anti- scratch shoe cover in order to protect the working surface .

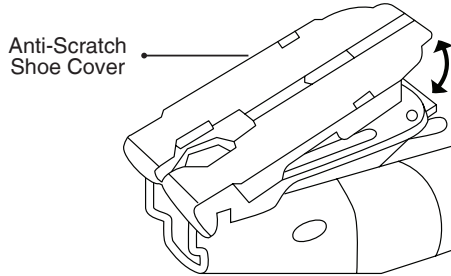

3) Use sawdust blower lever

The sawdust conducts an adjustable stream of air to the saw blade to keep the workpiece clear of sawdust during operation.

- Set the sawdust blower using the lever
- Low For working with metals, when using coolants and lubricants and for use with dust extraction.
- Intermediate For working with wood and similar materials in low speed.
- High For working with wood and similar materials in high speed.

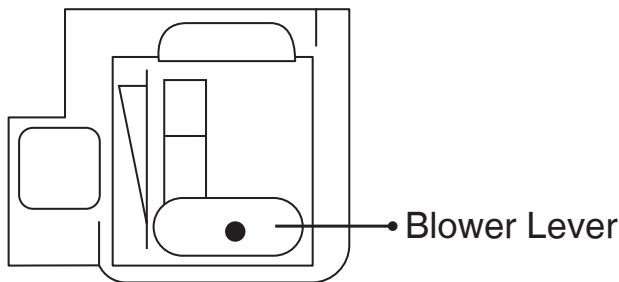

4) Dust extraction

When the tool is used indoor for extended periods of time, use a suitable dust extractor designed in compliant with applicable directives regarding dust emission.

The dust extraction tube in combination with the dust protector helps extracting the dust from the workpiece surface, when connected to a suitable dust extraction system.

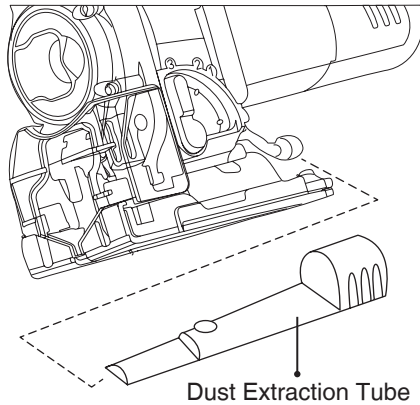

SERVICE AND MAINTENANCE

- 1) Always disconnect the tool before carrying out inspection or cleaning.
- 2) Never use water or other liquids to clean the tool. Clean the tool by brushing it with a brush.
- 3) Check and replace the carbon brush frequently.
- 4) The air-vent of the tool should be cleaned regularly to avoid the motor too hot due to air-vent blocked.
- 5) Always check if the components of the tool are fixed well.
- 6) The parts of tool should be without trace of crack or damage.
- 7) Always check if the cable is without damage.

■ REPLACING THE CARBON BRUSHES

▲ NOTE:

The carbon brush of this tool is internal type. Please replace the carbon brush only by our maintenance service center or dealers. Don't replace it by yourself.

- Replace the carbon brushes when the tool does not run and makes too much sparkle.
- Carbon brushes which are worn out (burned, broken or shorter than 5mm) have to be replaced by new ones.

- Always replace both carbon brushes at the same time and use the brush by **RONIX SERVICE**
- The brushes have to fall in the holders easily.
- After placing the new carbon brushes, let the tool run for some minutes so that the brushes fit better.

■ **REPAIRS**

Please only use accessories and spare part recommended by the Ronix. If the tool get malfunction, please hand over the tool to our dealer or appointed maintenance station. Don't disassemble the tool by yourself or replace the parts supplied by other factories.

WARRANTEE

- All the tools we produce are with the guarantee by our company.
- Damages that are attributable to improper handling, overloading, or natural wear and rear are excluded from the guarantee.
- The prerequisite is that the tool is handed over assembled, and completed with the proof of sate and guarantee. Don't disassemble the tool.
- For guarantee claim, only use the original packaging.

Ronix[®]
Premium Quality

www.ronixtools.com