

# Ronix<sup>®</sup>

Premium Quality

## DIE GRINDER

### 3401

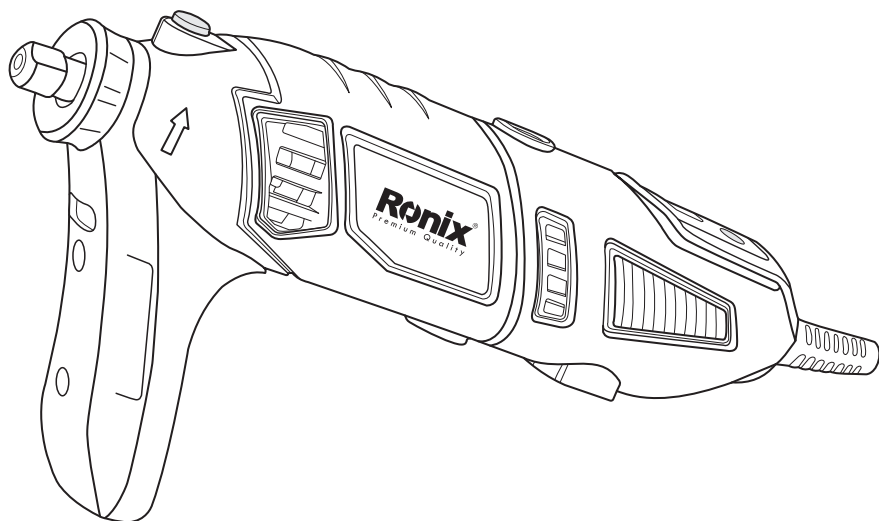

## SPECIFICATIONS

Model	3401
Voltage	240-220V
Power	170W
Frequency	50-60Hz
Weight	0.66kg
Bit Holder Size	3.2mm
Supplied In	BMC
No-Load Speed	8000-35000 RPM
Length of bending shaft	Approximately 1050 mm
Includes	Auxiliary Ronix-design handle, Pole support, Bending shaft, Limit position guard, Fixing clip, Different rotary tool accessories

## PARTS LIST

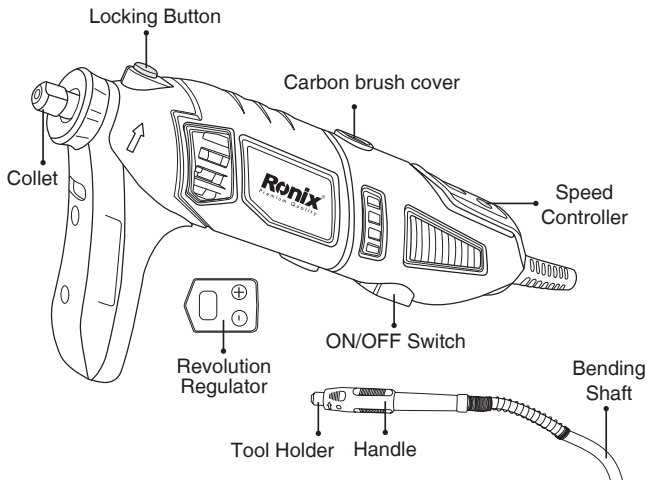

## BEFORE YOU BEGIN

### ■ INTENDED USE

When used for its intended purpose, this device corresponds to the state of the art, as well as to the current safety requirements at the time of its introduction. The device is designed for use as a grinder, sandpaper sander, wire brush, polisher and abrasive cutting tool in the specified dimensional and power range.

The device is not suitable for commercial or industrial use.

Any other type of use is inappropriate. Improper use or modifications to the device or the use of components that are not tested and approved by the manufacturer may result in unforeseen damage. Any use that deviates from its intended use and is not included in these instructions is considered unauthorized use and relieves the manufacturer from his or her legal liability.

What are the meanings of the symbols used?

Danger notices and information are clearly marked throughout these instructions for use. The following symbols are used:

### **DANGER!**

Direct danger to life and risk of injury!

Directly dangerous situation that may lead to death or severe injuries.

### **WARNING!**

Probable danger to life and risk of injury

Generally dangerous situation that may lead to death or severe injuries

### **CAUTION:**

Possible risk of injury

Dangerous situation that may lead to injuries

### **NOTICE:**

Risk of damage to the device

Situation that may lead to property damage

**⚠ NOTE:**

Information to help you reach a better understanding of the processes involved.



These symbols identify the required personal protection equipment.

## **SAFETY INSTRUCTIONS**

### **■ FOR YOUR SAFETY**

- To operate this device safely, the user must have read and understood these instructions for use before using the device for the first time.
- If you sell or pass the device on, you must also hand over these operating instructions.

### **■ GENERAL SAFETY INFORMATION FOR POWER TOOLS**

**⚠ WARNING!**

Read all instructions

Failure to follow all instructions listed below may result in electric shock, fire and/or serious injury.

- Store all safety notes and safety instructions for future reference. The term power tool in all of the warnings listed below refers to your mains operated (corded) power tool or battery operated (cordless) power tool.

### **■ SAFETY AT WORK**

- Keep work area clean and well lit.

Cluttered and dark areas invite accidents.

- Do not operate power tools in explosive atmospheres, such as in the presence of flammable liquids, gasses or dust. Power tools create sparks, which may ignite the dust or fumes.
- Keep children and bystanders away while operating a power tool. Distractions can cause you to lose control.

## ■ ELECTRICAL SAFETY

- Power tool plugs must match the outlet. Never modify the plug in any way. Do not use any adapter plugs with earthed (grounded) power tools. Unmodified plugs and matching outlets will reduce risk of electric shock.
- Avoid body contact with earthed or grounded surfaces such as pipes, radiators, ranges and refrigerators. There is an increased risk of electric shock if your body is earthed or grounded.
- Do not expose power tools to rain or wet conditions. Water entering a power tool will increase the risk of electric shock.
- Do not abuse the cord. Never use the cord for carrying, pulling or unplugging the power tool. Keep cord away from heat, oil, sharp edges or moving parts.

Damaged or entangled cords increase the risk of electric shock.

- When operating a power tool outdoors, use an extension cord suitable for outdoor use. Use of a cord suitable for outdoor use reduces the risk of electric shock.
- If operating a power tool in a damp location is unavoidable, use a residual current device (RCD) protected supply. Use of an RCD reduces the risk of electric shock.

## ■ PERSONAL SAFETY

- Stay alert, watch what you are doing and use common sense when operating a power tool. Do not use a power tool while you are tired or under the influence of drugs, alcohol or medication. A moment of inattention while operating power tools may result in serious personal injury.
- Use safety equipment. Always wear eye protection. Safety equipment such as dust mask, non-skid safety shoes, hard hat, or hearing protection used for appropriate conditions will reduce personal injuries.
- Avoid accidental starting. Ensure the switch is in the off position before plugging in. Carrying power tools with your finger on the switch or plugging in power tools that have the switch on invites accidents.
- Remove any adjusting key or wrench before turning the power tool on. A wrench or a key left attached to a rotating part of the power tool may

result in personal injury.

- Do not overreach. Keep proper footing and balance at all times. This enables better control of the power tool in unexpected situations.
- Dress properly. Do not wear loose clothing or jewelry. Keep your hair, clothing and gloves away from moving parts. Loose clothes, jewelry or long hair can be caught in moving parts.
- If devices are provided for the connection of dust extraction and collection facilities, ensure these are connected and properly used. Use of these devices can reduce dust related hazards.

### ■ **POWER TOOL USE AND CARE**

- Do not force the power tool. Use the correct power tool for your application. The correct power tool will do the job better and safer at the rate for which it was designed.
- Do not use the power tool if the switch does not turn it on and off. Any power tool that cannot be controlled with the switch is dangerous and must be repaired.
- Disconnect the plug from the power source before making any adjustments, changing accessories, or storing power tools. Such preventive safety measures reduce the risk of starting the power tool accidentally.
- Store idle power tools out of the reach of children and do not allow persons unfamiliar with the power tool or these instructions to operate the power tool. Power tools are dangerous in the hands of untrained users.
- Maintain power tools. Check for misalignment or binding of moving parts, breakage of parts and any other condition that may affect the power tools operation. If damaged, have the power tool repaired before use. Many accidents are caused by poorly maintained electrical tools.
- Keep cutting tools sharp and clean.  
Properly maintained cutting tools with sharp cutting edges are less likely to bind and are easier to control.
- Use the power tool, accessories and tool bits etc. in accordance with these instructions and in the manner intended for the particular type of

power tool, taking into account the working conditions and the work to be performed. Use of the power tool for operations different from intended could result in hazardous situation.

#### ■ SERVICE

- Have your power tool serviced by a qualified repair person using only identical replacement parts. This will ensure that the safety of the power tool is maintained.

#### ■ SHARED SAFETY NOTES REGARDING GRINDING, SANDPAPER SANDING, WORKING WITH WIRE BRUSHES, POLISHING AND ABRASIVE CUTTING.

- This power tool is to be used as a sandpaper grinder, sandpaper sander, wire brush, polisher and abrasive cutting tool. Observe all the safety notes, instructions, representations and data received with the power tool. If you do not observe the following instructions, electrical shock, fire and/or serious injuries may be the result.

- Do not use accessories that have not been designed and recommended by the manufacturer for this specific power tool. Just because you are able to attach an accessory to your power tool this does not guarantee that it is safe to use.

- The permitted revolutions of the tool must be at least as high as the highest revolutions specified on the power tool. Accessories that rotate faster than they are permitted to may break and fly.

- The external diameter and thickness of the tool must match the dimensional specification of your power tool.

Incorrectly dimensioned tools cannot be sufficiently shielded or controlled.

- Sanding discs, flanges, sanding plates or other accessories must fit precisely to the sanding spindle of your power tool. Tools that do not fit precisely to the sanding spindle of the power tool will rotate unevenly, vibrate heavily and may cause loss of control over the device.

- Do not use damaged tools. Before each use, check tools like sanding discs for chips and tears, sanding plates for tears, wear or heavy use,

wire brushes for loose or broken bristles. If the power tool or the tool itself is dropped, check to see whether it is damaged or use an undamaged tool. When you have checked and inserted the tool, ensure that you and any other people in the vicinity are out of the sphere of influence of the rotating tool and operate the power tool for a minute at the highest revolutions. Damaged tools will usually break within this test period.

- Wear personal safety gear. Depending on the work you are doing, wear a full- face visor, visor or protective goggles. If appropriate, wear a dust mask, ear defenders, protective gloves or a special apron designed to keep sanding and material particles away from you. Your eyes should be protected from the flying objects that may be generated during various applications. Dust or breathing masks must be capable of filtering the dust generated during operation. If you are exposed to loud noise for extended periods, you may suffer a loss of hearing.

- Ensure that other people are kept a safe distance from your workplace. Anyone entering the workplace must wear personal protective gear. Pieces of the work piece or broken tools may fly away and cause injuries even outside the direct working area.

- Hold the device by the insulated surfaces only when carrying out work during which it is possible that the tool may come across hidden power cables or its own cable. Contact with a cable that carries power will subject the metal parts of the device to current and will lead to electrical shock.

- Keep the power cable away from rotating tools. If you lose control over the power tool, the power cable may be cut or caught and your hand or arm may be pulled into the rotating tool.

- Never set the power tool down before the tool has come to a completed standstill. The rotating tool may come into contact with the surface and cause you to lose control over the power tool.

- Never operate the power tool when you are carrying it. Your clothing may be caught as a result of accidental contact with the rotating tool causing the tool to injure you.

- Clean the ventilation slots of your power tool regularly. The motor fans draw dust into the housing and a large deposit of metal dust can cause



electrical hazards.

- Never use power tool near flammable materials. Sparks may set fire to these materials.
- Do not use tools that require a liquid cooling agent. The use of water or other liquid cooling agents may lead to electrical shock.

## ■ KICKBACK AND THE APPROPRIATE SAFETY NOTES

Kickback is a sudden reaction caused as a result of a jammed or blocked rotating tool, for example, a sanding disc, sanding plate, wire brush etc. Jamming or blocking causes the rotating tool to come to an abrupt stop. This causes an uncontrolled power tool to accelerate against the direction of rotation of the tool at the blocked point.

For example, if a grinding disc becomes stuck or blocked in a work piece, the edge of the grinding disc that dips into the work piece may get caught and the grinding disc will break away or cause kickback. The grinding disc will then move towards the operator or away from them in accordance with the direction of rotation of the disc at the blocked point. This may also cause grinding discs to break.

A kickback is a consequence of incorrect or faulty use of the power tool. It can be pre-vented by the use of suitable measures, as described below:

- Hold the power tool securely with both hands and position your body and arms in such a way that you are able to absorb any kickback. Always use the additional handle, if there is one available, in order to ensure you have the greatest possible control over kickback forces or reaction torque when the tool is at top speed. The operator is able to master kickback or reaction forces if they take the appropriate care
- Never put your hand close to the rotating tool. The tool may move over your hand in the event of kickback
- Keep your body out of the area that the power tool would jump to in the event of kickback. Kickback pushes the power tool in the opposite direction to the movement of the sanding disc at the blocked point.
- Be especially careful around corners, sharp edges etc. Avoid tools bouncing off work pieces and becoming jammed. The rotating tool will

tend to jam at corners, sharp edges or when it bumps against something. This will lead to a loss of control or kickback.

- Do not use chained or toothed saw blades. Such tools will often cause kick-back of the loss of control over the power tool.

### **■ SPECIAL SAFETY NOTES REGARDING GRINDING AND ABRASIVE CUTTING**

- Only use grinding tools permitted for use with your power tool and the protective hood designed for use with these tools. Grinding tools that have not be designed for use with the power tool cannot be sufficiently shielded and are thus unsafe.

- Grinding tools may only be used for the purposes recommended. For example: Never use the side surface of a cutting disc to grind. Cutting discs are designed to be used to remove material with the edge of the disc. Lateral forces on these tools may break them

- Always used undamaged tensioning flanges in the correct size and shape for the cutting disc you have selected.

Suitable flanges support the cutting disc and thus reduce the risk of the disc breaking. Flanges for cutting discs may differ from flanges for other grinding discs

- Do not use worn grinding disc from larger power tools. Grinding discs for larger power tools are not designed to cope with the higher revolutions of smaller power tools and may break

### **■ FURTHER ADDITIONAL SAFETY NOTES REGARDING ABRASIVE CUTTING.**

- Avoid jamming the cutting disc or applying too high a pressure. Do not carry out any excessively deep cuts. Overloading the cutting disc increases the pressure and the tendency to tilt or block and thus increases the risk of kick-back or of the disc breaking.

- Avoid the area in front of and behind the rotating disc. If you operate the device in such a way that the cutting disc in the work piece is moved away from you, in the event of kickback, the power tool and the rotating

disc may be thrown towards you.

- If the cutting disc is jammed or you need to interrupt your work, switch the power tool off, and hold it motionless until the disc has come to a standstill. Never attempt to pull a still operating cutting disc out of the cut as this may cause kickback. Investigate and take corrective actions to eliminate the cause of the jam.
- Do not switch the power tool back on as long as it remains stuck in the work piece. Allow the cutting disc to achieve the full revolutions before you continue to cut carefully. Otherwise, the disc may get caught, jump out of the work piece or cause kickback.
- Support panels or large work pieces to minimize the risk of kickback caused by a trapped disc. Large work pieces may bend under their own weight. The work piece must be supported on both sides, near the line of cut and near the edge.
- Be very carefully when making plunge cuts in existing walls or in other areas that are difficult to see. The plunging disc may cut into gas or water pipes, electrical cables or other objects and cause kickback.

#### **■ SPECIAL SAFETY NOTES REGARDING SAND-PAPER SANDING**

- Do not use over dimensioned sanding sheets, instead following the manufacturer's instructions regarding size. Sanding sheets that protrude beyond the sanding plate may cause injuries, jamming and tearing of the sheets or cause kickback.

#### **■ SPECIAL SAFETY NOTES REGARDING POLISHING**

- Do not permit parts of the polishing hood to be loose, in particular, fixing cords. Conceal or shorten fixing cords. Loose, rotating fixing cords may catch your fingers or get trapped in the work piece.

#### **■ SPECIAL SAFETY NOTES REGARDING WORKING WITH WIRE BRUSHES**

- Please note that wire brushes will lose wire bristles during normal operation. Do not overload the wires by applying too high a pressure.

Flying wire bristles may easily pass through very thing clothing and/or skin.

- If a protective good is recommended, make sure that the hood and the wire brush do not make contact. Wheel and cup brushes may increase in diameter as a result of pressure and centrifugal forces.

## ■ ADDITIONAL SAFETY NOTES

- Prior to starting work, use appropriate tool to determine whether there are any hidden supply lines are located on the area you are working in. If in doubt, ask the relevant supply services. Contact with power lines may cause fire and electrical shock. Damaging a gas pipe may cause an explosion. Damaging a water pipe leads to considerable property damage and may cause electrical shock.

- Avoid uncontrolled restarting. Switch the tool off when the power supply is interrupted, for example, by a power failure or pulling the plug.

- Secure the work piece. Use tensioning equipment or a vice to secure the work piece to help prevent kickback or uncontrolled flying of the work piece (e.g. when getting jammed in the work piece.)

- Keep your workplace clean. Mixed contamination by various materials is particularly dangerous. Light metal dust (e.g. aluminum) can ignite or explode easily.

- Inform yourself about the surface to be sanded and any dusts and vapors that may be generated. If in doubt, do not breathe in even small amounts of the generated dusts and vapors. When sanding certain surfaces (various metals, minerals or woods as well as weather protecting paints) damaging/poisonous dusts may be generated which can cause allergic reactions or serious illness. Do not breathe these dusts and vapors in and avoid all contact. Materials containing asbestos may only be processed by specialists.

- Never use the power too with a damaged cable. Do not touch a damaged cable and pull out the power plug. Damaged cables increase the risk of electric shock.

- Keep cutting tools sharp and clean.

Properly maintained cutting tools with sharp cutting edges are less likely

to jam and are easier to control.

- Prevent overheating of the device and the work piece. Excess heat may damage the tool and the device.
- Shortly after being used, the tool may be very hot. Allow a hot tool to cool down. Touching a hot tool may cause burns.
- Never clean a hot tool with flammable liquids. There is a risk of fire and explosion.
- Keep the handles dry and free of grease. Slippery handles can lead to accidents.
- Always comply with the all applicable domestic and international safety, health, and working regulations.

Inform yourself before you start work about the regulations that apply at the site of the device.

- Remember that moving parts may also be located behind ventilation and venting slots.
- Symbols appearing on your product may not be removed or covered. Signs on the product that are no longer legible must be replaced immediately.



Read and observe the instructions for use before using the product for the first time.

## ■ RISKS CAUSED BY VIBRATIONS

### CAUTION:

Risk of injury due to vibrations!

Vibrations may, in particular for per-sons with circulation problems, cause damage to blood vessels and/ or nerves.

If you notice any of the following symptoms, stop working immediately and consult a doctor. Numbness of body parts, loss of sense of feeling, itching, pins and needles, pain, changes in skin color.

The vibration values specified in the technical data represent the main uses of the device. The actual existing vibrations during use may

deviate from these as a result of the following factors:

- Incorrect use of the product
- Unsuitable tools inserted
- Unsuitable material
- Insufficient maintenance

You can reduce the risks considerably by following the tips below:

- Maintain the device in accordance with the instructions in the operating instructions.
- Avoid working at low temperatures.
- When it is cold, make sure your body and your hands, in particular, are kept warm.
- Take regular breaks and move your hands at the same time to promote circulation.

### ■ REMAINING RISKS

There will still be residual risks even when the device is used according to the instructions and under observation of all of the safety notes in this set of operating instructions:

- Touching the tool in the uncovered section.
- Reaching into the operating tool.
- Kickback from work pieces and work piece parts.

### ■ PERSONAL PROTECTIVE CLOTHING



Wear goggles when working with the device.



When working with tools that cause considerable dust, wear a dust protection mask.



If you have long hair, cover or wear a hair net.



Do not wear protective gloves when working with the device.

## ■ SCOPE OF DELIVERY

- Operating manual
- Axial grinder
- Case
- Bending shaft
- Installation wrench
- Tool stand
- Additional handle
- Depth stop
- Collet chucks (various diameters)
- Coupling nut
- Locking pin for the bending shaft
- Various sanding/grinding bodies
- Polishing and cutting discs
- Drill
- Sanding/grinding bits

## NOTE:

If any one of the parts is missing or damaged, contact the retailer.

## OPERATION



## ■ CHECK BEFORE SWITCHING ON!

- Check to make sure the unit is in a safe operating condition.
- Check to make sure there are no visible defects.
- Check to make sure all unit components are correctly mounted.

## ■ INSERTING A TOOL

### ⚠ CAUTION:

Risk of injury

Only use tools approved by the manufacturer.

Never use damaged tools. Always check tools for tears and other damage before mounting.

Only use tools that are appropriate for the material you are processing. Only use tools with a permitted revolution that is at least as high as the idle revolutions of the unit.

- 1) Fit the appropriate collet chuck for the tool into the tool holder.
- 2) Screw the coupling nut into place.
- 3) Fit the required tool into the collet chuck.
- 4) Press and hold down the locking button.
- 5) Tighten the coupling nut with the supplied mounting wrench.

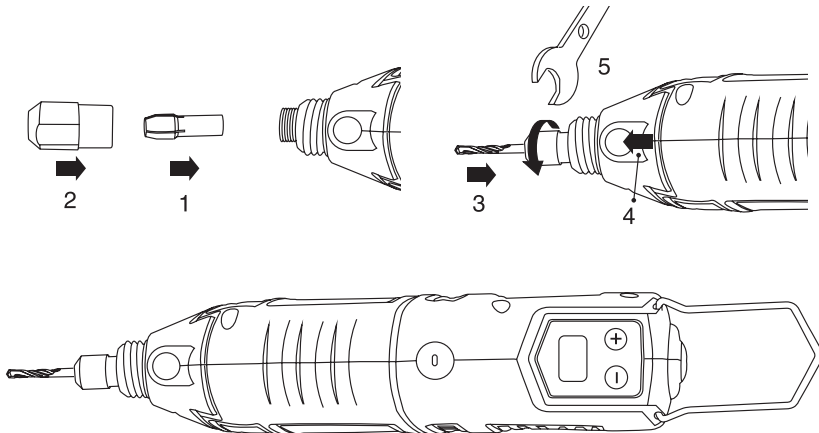

## ■ USING THE BENDING SHAFT

### ⚠ NOTICE:

Risk of damage to the unit

Do not fold the bending shaft or bend too tightly.

- 1) Fit a collet chuck with 02 mm in the tool holder.



- 2) Screw the coupling nut into place.
- 3) Fit the shaft of the bending shaft into the collet chuck.
- 4) Press and hold down the locking button.
- 5) Tighten the coupling nut with the sup-plied mounting wrench.
- 6) Place the coupling nut of bending shaft onto the device.
- 7) Tighten the coupling nut.

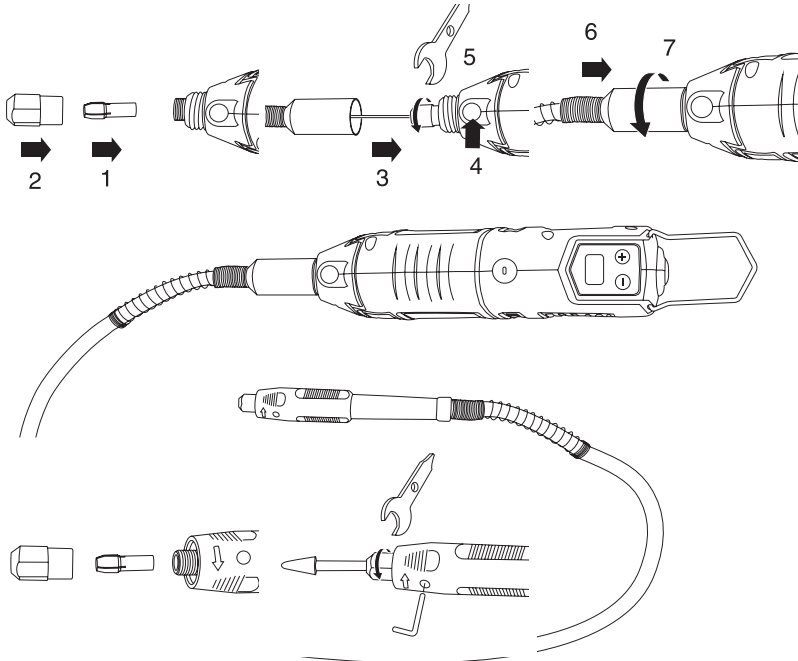

## ■ INSERTING A TOOL

- 1) Fit the appropriate collet chuck for the tool into the tool holder.
- 2) Screw the coupling nut into place.
- 3) Fit the required tool into the collet chuck.
- 4) Fix the bending shaft with the locking pin.
- 5) Tighten the coupling nut with the sup-plied mounting wrench and remove the locking pin.

## ■ ATTACHING THE ADDITIONAL HANDLE

- Push the additional handle (7) over the tool holder.
- Tighten the coupling nut. (8)

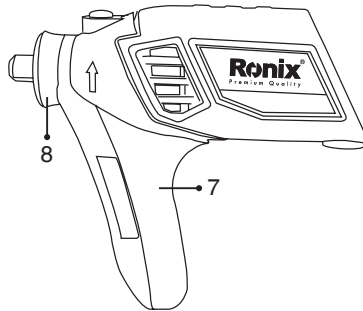

## ■ SWITCHING ON AND OFF

### ⚠ NOTICE:

Risk of damage to the unit!

The motor may overheat in the event of permanent heavy loads and low revolutions. Run the motor at higher revolutions in idle to allow it to cool down.

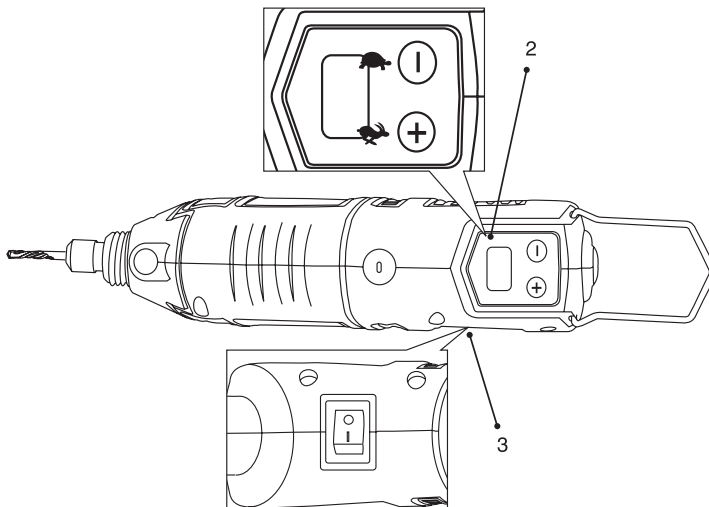

- 1) Switching on: push the On/Off switch (3) to position (I).  
Switching off: push the On/Off switch (3) to position (0).
- 2) Regulating the revolutions: set the revolution regulator (2) to the required level.

## NOTES ON USING DEVICE

### **WARNING!**

Risk of injury!

Don't tilt work piece and tool. Risk of injury due to flying broken pieces!

### **NOTICE:**

Risk of damage to the unit!

Don't fold the bending shaft or bend too tightly.

### **NOTE:**

Excessive pressure does not result in greater performance instead it cause greater wear on the tools.

- Always hold work pieces securely or clamp into place.
- Do not tilt work piece and tool.
- When milling or engraving hold the device as if it were a writing implement.
- For coarse work, hold the device as if it were a hammer.

The following guidelines apply to the tool revolutions:

- Plastic and materials with a low melting point must be processed at lower revolutions.
- To polish or clean using wire brushes select a low revolution level in order to prevent damages by the brushes.
- Wooden materials should be processed at higher revolutions.
- Iron and steel should be processed at higher revolutions.
- Dampening the tool with petroleum or another suitable lubricant will prevent shavings from sticking to the cut surfaces.

## CLEANING

### ■ CLEANING OVERVIEW

Regularly and according to the operating conditions:

What	How
Clean the ventilation Use a vacuum, slots of the motor to cleaning brush or remove dust.	Use a vacuum, cleaning brush or paint brush
Clean the device.	Wipe the unit with a damp cloth.
Lubricating the bending shaft.	Remove the shaft from the protective cover and grease lightly.

## TROUBLESHOOTING

What to do when something doesn't work...

### DANGER!

Risk of injury!

Unprofessional repairs may mean that your unit will no longer operate safely. This endangers you and your environment.

In many cases, small defects can lead to a malfunction. You will usually be able to deal with yourself. Please refer to the table below before contacting your local Ronix store. This may save you a lot of effort and quite often money.

Error/Fault	Cause	Remedy
The motor does not work	No power supply	Check the cable, plug, and the fuse.
	Defective connecting cable	Contact your local Ronix store.

If you are unable to eliminate the error yourself, please contact your local Ronix store directly. Please remember that repairs carried out by non-professionals will invalidate your warranty claim and may cause additional costs.

## **DISPOSAL**

### **■ DISPOSAL OF THE APPLIANCE**

Appliances which are labeled with the adjacent symbol must not be disposed of in household waste. You must dispose of such old electrical and electronic equipment separately.

- Please check with your local authority about the possibilities for correct disposal.

Through separate disposal you send old equipment for recycling or for other forms of reuse. You will thus help to avoid in some cases that damaging material gets into the environment.

### **■ DISPOSAL OF THE PACKAGING**

- The packaging consists of cardboard and correspondingly marked plastics that can be recycled.

- Make these materials available for recycling.

**Ronix**<sup>®</sup>  
Premium Quality

[www.ronixtools.com](http://www.ronixtools.com)