

Ronix®

Premium Quality

SHORT NECK & LONG NECK DIE-GRINDER 3302

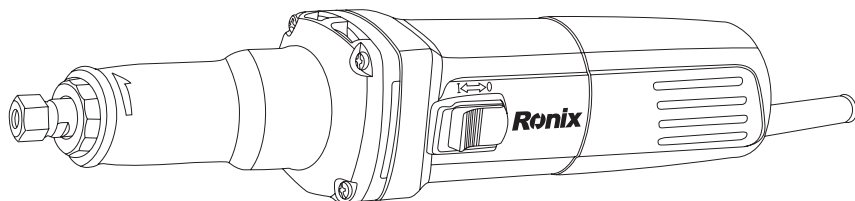

www.ronixtools.com

12
MONTHS
GUARANTY

FREE
DELIVERY

BANK
SPARE PARTS

CALL
CENTER
02161904

SPECIFICATION

Model No.	3302
Voltage	220V
Frequency	50/Hz
Rated power	710W
No-load speed	12000-28000RPM
Collet size	6mm
Max heel diameter	25mm

PART LIST

WARNING!

Read all safety warnings and all instructions. Failure to follow the warnings and instructions may result in electric shock, fire and/or serious injury.

Save all warnings and instructions for future reference.

The term “power tool” in the warnings refers to your mains-operated (corded) power tool or battery-operated (cordless) power tool.

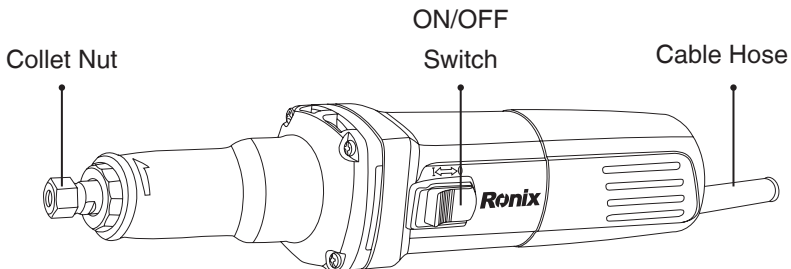

■ WORK AREA SAFETY

- Keep work area clean and well lit. Cluttered or dark areas invite accidents.
- Do not operate power tools in explosive atmospheres, such as in the

presence of flammable liquids, gases or dust. Power tools create sparks which may ignite the dust or fumes.

-Keep children and bystanders away while operating a power tool. Distractions can cause you to lose control.

■ ELECTRICAL SAFETY

-Power tool plugs must match the outlet. Never modify the plug in any way. Do not use any adapter plugs with earthed (grounded) power tools. Unmodified plugs and matching outlets will reduce risk of electric shock.

-Avoid body contact with earthed or grounded surfaces, such as pipes, radiators, ranges and refrigerators. There is an increased risk of electric shock if your body is earthed or grounded.

-Do not expose power tools to rain or wet conditions. Water entering a power tool will increase the risk of electric shock.

-Do not abuse the cord. Never use the cord for carrying, pulling or unplugging the power tool. Keep cord away from heat, oil, sharp edges or moving parts. Damaged or entangled cords increase the risk of electric shock.

-When operating a power tool outdoors, use an extension cord suitable for outdoor use. Use of a cord suitable for outdoor use reduces the risk of electric shock.

-If operating a power tool in a damp location is unavoidable, use a residual current device (RCD) protected supply. Use of an RCD reduces the risk of electric shock.

■ PERSONAL SAFETY

-Stay alert, watch what you are doing and use common sense when operating a power tool. Do not use a power tool while you are tired or under the influence of drugs, alcohol or medication. A moment of inattention while operating power tools may result in serious personal injury.

-Use personal protection used for appropriate conditions will reduce personal injuries.

-Prevent unintentional starting. Ensure the switch is the off-position before connecting to power source and/or battery pack, picking up or

carrying the tool. Carrying power tools with your finger on the switch or energizing power tools that have the switch on invites accidents.

-Remove any adjusting key or wrench before turning the power tool on. A wrench or a key left attached to a rotating part of the power tool may result in personal injury.

-Do not overreach. Keep proper footing and balance at all times. This enables better control of the power tool in unexpected situations.

-Dress properly. Do not wear loose clothes or jewelries. Keep your hair, clothes and gloves away from moving parts. Loose clothes, jewelries or long hair can be caught in moving parts.

If devices are provided for the connection of dust extraction and collection facilities, ensure these are connected and properly used. Use of dust collection can reduce dust-related hazards.

■ POWER TOOL USE AND CARE

-Do not force the power tool. Use the correct power tool for your application. The correct power tool will do the job better and safer at the rate for which it was designed.

-Do not use the power tool if the switch does not turn it on and off. Any power tool that cannot be controlled with the switch is dangerous and must be repaired.

-Disconnect the plug from the power source and/or the battery pack from the power tool before making any adjustments, changing accessories, or storing power tools. Such preventive safety measures reduce the risk of starting the power tool accidentally.

-Store idle power tools out of the reach of children and not allow persons unfamiliar with the power tool or these instructions to operate the power tool. Power tools are dangerous in the hands of untrained users.

-Maintain power tools. Check for misalignment or binding of moving parts, breakage of parts and any other condition that may affect the power tool's operation. If damaged, have the power tool repaired before use. Many accidents are caused by poorly maintained power tools.

-Keep cutting tools sharp and clean. Properly maintained cutting tools

with sharp cutting edges are less likely to bind and are easier to control.

- Use the power tool, accessories and tool bits etc. in accordance with these instructions, taking into account the working conditions and the work to be performed. Use of the power tool for operations different from those intended could result in a hazardous situation.

■ SERVICE

- Have your power tool serviced by a qualified repair person using only identical replacement parts. This will ensure that safety of the power tool is maintained.

- This power tool is intended to function as a grinder, sander, wire brush, polisher or cut-off tool. Read all safety warnings, instruction, illustrations and specifications provided with this power tool. Failure to follow all instructions listed below may result in electric shock, fire and/or serious injury.

- Do not use accessories which are not specifically designed and recommended by the tool manufacturer. Just because the accessory can be attached to your power tool, it does not assure safe operation.

- The rated speed of the accessory must be at least equal to the maximum speed marked on the power tool. Accessories running faster than their rated speed can break and fly apart.

- The arbor size of wheels, flanges, backing pads or any other accessory must properly fit the spindle of the power tool. Accessories with arbor holes that do not match the mounting hardware of the power tool will run out of balance, vibrate excessively and may cause loss of control.

- Do not use a damaged accessory. Before each use inspect the accessory such as abrasive wheels for chips and cracks, backing pad for cracks tear or excess wear, wire brush for loose or cracked wires. If power tool or accessory. After inspecting and installing an accessory, position yourself and bystanders away from the plane of the rotating accessory and run the power tool at maximum no-load speed for one minute. Damaged accessories will normally break apart during this test time.

- Wear personal protective equipment. Depending on application, use face shield, safety goggles or safety glasses. As appropriate, wear dust mask,

hearing protectors, gloves and workshop apron capable of stopping small abrasive or work piece fragments. The eye protection must be capable of stopping flying debris generated by various operations. The dust mask or respirator must be capable of filtering particles generated by your operation. Prolonged exposure to high intensity noise may cause hearing loss.

-Keep bystanders a safe distance away from work area. Anyone entering the work area must wear personal protective equipment. Fragments of work piece or of a broken accessory may fly away and cause injury beyond immediate area of operation.

-Hold power tool by insulated gripping surfaces only, when performing an operation where the cutting accessory may contact hidden wiring or its own cord. Cutting accessory contacting a “live” wire may make exposed metal parts of the power tool “live” and shock the operator.

-Position the cord clear of the spinning accessory. If you lose control, the cord may be cut or snagged and your hand or arm may be pulled into the spinning accessory.

-Never lay the power tool down until it has stopped completely

-Do not run the power tool while carrying it at your side. Accidental contact with the spinning accessory could snag your clothing, pulling the accessory into your body.

-Regularly clean the power tool’s air vents. The motor’s fan will draw the dust inside the housing and excessive accumulation of powdered metal may cause electrical hazards.

-Do not operate the power tool near flammable materials. Sparks could ignite coolants may result in electrocution or shock.

KICKBACK AND RELATED WARNINGS

Kickback is a sudden reaction to a pinched or snagged rotating wheel, backing pad, brush or any other accessory. Pinching or snagging causes rapid stalling of the rotating accessory which in turn causes the uncontrolled power tool to be forced in the direction opposite of

the accessory's rotation at the point of the binding. For example, if an abrasive wheel is snagged or pinched by the work piece, the edge of the wheel that is entering into the pinch point can dig into the surface of the material causing the wheel to climb out or kick out. The wheel may either jump toward or away from the operator, depending on direction of the wheel's movement at the point of pinching. Abrasive wheels may also break under these conditions. Kickback is the result of power tool misuse and/or incorrect operating procedures or conditions and can be avoided by taking proper precautions as given below.

- Maintain a firm grip on the power tool and position your body and arm to allow you to resist kickback forces. Always use auxiliary handle, if provided, for maximum control over kickback or torque reaction during start-up. The operator can control torque reactions or kickback forces, if proper precautions are taken.

- Never place your hand near the rotating accessory. Accessory may kickback over your hand.

- Do not position your body in the area where power tool will move if kickback occurs. Kickback will propel the tool in direction opposite to the wheel's movement at the point of snagging.

- Use special care when working corners, sharp edges etc. Avoid bouncing and snagging the accessory. Corners, sharp or bounced edges have a tendency to snag the rotating accessory and cause loss of control or kickback.

- Do not attack a saw chain woodcarving blade or toothed saw blade. Such blades create frequent kickback and loss of control.

SAFETY WARNINGS SPECIFIC FOR GRINDING AND ABRASIVE CUTTING-OFF OPERATIONS

- Use only wheel types that are recommended for your power tool and the specific guard designed cannot be adequately guarded and are unsafe.

- The guard must be securely attached to the power tool positioned for

maximum safety, so the least amount of wheel is exposed towards the operator. The guard helps to protect operator from broken wheel fragments and accidental contact with wheel.

-Wheels must be used only for recommended applications. For example: do not grind with the side of cut-off wheel. Abrasive cut-off wheels are intended for peripheral grinding, side forces applied to these wheels may cause them to shatter.

-Do not restart the cutting operation in the work piece. Let the wheel reach full speed and carefully reenter the cut. The wheel may bind, walk up or kickback if the power tool is restarted in the work piece.

-Support panels or any oversized work piece to minimize the risk of wheel pinching and kickback. Large work pieces tend to snag under their own weight. Supports must be placed under the work piece near the line of cut and near the edge of the work piece on both sides of the wheel.

-Use extra caution when making a “pocket cut” into existing walls or other blind areas. The protruding wheel may cut gas or water pipes, electrical wiring or objects that can cause kickback.

SAFETY WARNINGS SPECIFIC FOR SANDING OPERATIONS

Do not use excessively oversized sanding disc paper. . Follow manufacturer’s recommendations, when selecting sanding paper. Larger sanding paper extending beyond the sanding pad presents a laceration hazard and may cause snag, tearing of the disc or kickback.

SAFETY WARNINGS SPECIFIC FOR WIRE BRUSHING OPERATIONS

-Be aware that wire bristles are thrown by the brush even during ordinary operations. Do not overstress the wires by applying excessive load to the brush. The wire bristles can easily penetrate light clothing and/or skin.

-If the use of a guard is recommended for wire brushing, do not allow any interference of the wire wheel or brush with the guard. Wire wheel or brush may expand in diameter due to work load and centrifugal forces.

ADDITIONAL SAFETY REGULATIONS

-Wear safety goggles.

-Use suitable detectors to determine if utility lines are hidden in the work area or call the local utility company for assistance. Contact with electric lines can lead to fire and electric shock. Damaging a gas line can lead to explosion. Penetrating a water line causes property damage or may cause an electric shock.

-Release the on/off switch and set it the off position when the power supply is interrupted, e. g., in case of a power failure or when the mains plug is pulled. This prevents uncontrolled restarting.

-When working stone, use dust extraction. The vacuum cleaner must be approved for the extraction of stone dust. Using this equipment reduces dust-related hazards.

-Use a cutting guide when cutting stone. Without sideward guidance, the cutting disc can jam and cause kickback.

-When working stone, use dust extraction. The vacuum cleaner must be approved for the extraction of stone dust. Using this equipment reduces dust-related hazards.

-When working with the machine, always hold it firmly with both hands and provide for a secure stance. The power tool is guided more secure with both hands.

-Secure the work piece. A work piece clamped with clamping devices or in a vice is held more secure than by hand.

-Keep your workplace clean. Blends of materials are particularly dangerous. Dust from light alloys can burn or explode.

-Never use the machine with a damaged cable. Do not touch the damaged cable and pull the mains plug when the cable is damaged while working. Damaged cables increase the risk of an electric shock.

ASSEMBLY

WARNING!

Switch off the die grinder and disconnect it from the power point.

NOTE:

Make sure the main voltages match on the machine's rating label.

■ FITTING THE GRINDING POINT

-Insert the grinding points which on the hole of the central spindle (2), then adjust the grinding point to the fit position distance away from the edge of the spindle.

-Rivet the spindle with second spanner then tighten the collet nut firmly in clockwise direction using the spanner.

Make the die grinder run in idle for at least a minute with the grinding point correctly assembled, the grinding point should be immediately replaced if there is the vibration.

OPERATING

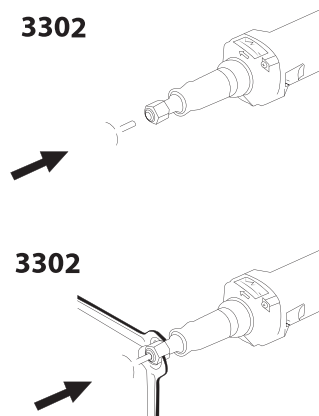

⚠ WARNING!

Excessive pressure on machine done not necessarily lead the high working power and speed; On the contrary, it increases the wear on the grinding point can damage the die grinder.

NOTE:

The switch on this tools is fitted with a locking device, allowing the tool to be operated for long periods of time without interruptions. Before inserting the unlocked position.

■ SWITCH ACTION

- Hold the tool firmly with both hands when starting the tool.
- Start the tool by pushing the switch to the position of “I” then pressing down switch, it will be locked.
- Pressing the switch which “O” of the housing when the stop the machine, the switch will be position of unblocked.

■ SPEED CONTROLLER ACTION

Speed of die grinder can be adjusted by turning the speed controller to a given number setting from 12000 to 28000.

3302

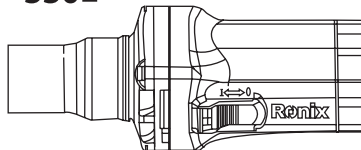

■ HIGH SPEED

Timing switch is turned in direction of number 6.

■ LOW SPEED

Timing speed is turned in direction of number 1.

The number setting on the speed controller is equal to the tool speed.

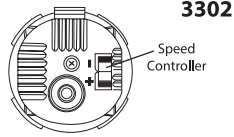

⚠ WARNING!

If the tool is operated continuously at low speeds for a long time, the motor will get overloaded, resulting in tool malfunction. The speed adjusting dial can be turned only as far as 28000 and back to 12000. Do not force it past 28000 or 12000, or the speed adjusting function may no longer work.

OPERATING INSTRUCTION

NOTE:

The die grinder can be used for grinding steel or ceramic work pieces such as pipe, box section, rectangular, angle iron steel bar, should, household bricks and tiles. Don't attempt to grind a soft metal such as lead. The material will quickly "fill" the disc and render it useless. Before starting the grinder first ensure that the grinding point, collet nut and tool are in good condition. Do not cover ventilation when the tool is in use. This may cause damage to the motor and reduce the efficiency of the tool.

■ GRINDING

The best results are achieved with an angle of 0 to 30 for grinding. Move the machine left and right with light pressure. In this manner, the work piece does not become too hot, no discoloration occurs and no ridges are produced.

⚠ WARNING!

When begin the operating, must be grind with the little press, and touch the small area of work piece, then increase the press stepwise under rated power.

MAINTENANCE AND INSPECTION

WARNING!

Regular inspection and maintenance the part of mechanical of the machine each 100 hours, such as spindle, bearing etc., and if they are not agility, add the greasing to them replacing them in the authorized service agent if the bearing damaged.

Always be sure that the tool is switched off before attempting to perform inspection or maintenance.

- The armature and stator is the heart of the power tool. Exercise due care to ensure they don't become damaged or effected by oil or water.
- The carbon brushes should be checked periodically and worn out carbon brushes should be replaced in time. After replacing. Inspect whether the new carbon brushes can move freely in the brush holder. Keep running the motor for 15 minutes to match the contact of the carbon brushes and commutator.
- Regularly inspect all mountings and screws and ensure they are property tightened. Showed any of screws be loose, tighten them immediately. Failure to do so may result in serious damage.
- The supply cord of the tool and any extension cord used should be checked frequently for damage. If it is damaged, have the new cord replaced by an authorized service facility. Replaced the extension cord if necessary.
- Consult the authorized service agent about the event of failure.
- Clean the dust of the tool after each use.

Ronix[®]
Premium Quality

www-ronixtools-com