

Ronix[®]

Premium Quality

DEMOLITION HAMMER 2818

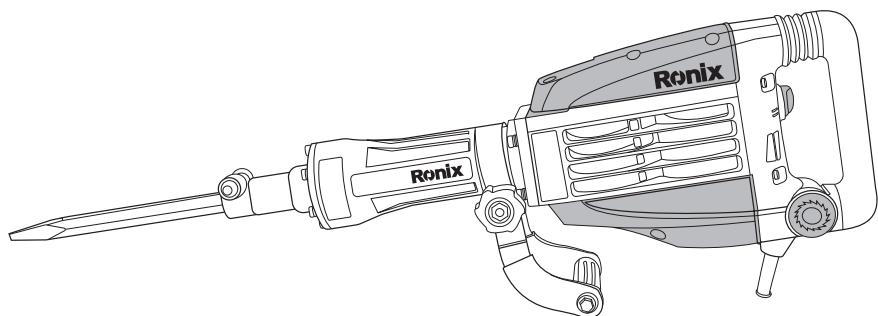

SPECIFICATIONS

| | |
|------------------|------------------------------|
| Model | 2818 |
| Input power | 1700W |
| Voltage | 220-240V |
| Frequency | 50-60Hz |
| Impact rate | 1400bpm |
| Chuck Type | HEX |
| Chuck Size | 30 MM |
| Weight(w/o cord) | 18KG |
| Impact energy | 55J |
| Supplied in | Ronix Wheel- chair BMC |

STANDARD ACCESSORIES

| | |
|------------------------------|----------|
| Bull point chisel (410*30mm) | 1 Piece |
| Flat chisel (410*30mm) | 1 Piece |
| Carbon brush | 1 Couple |

PARTS LIST

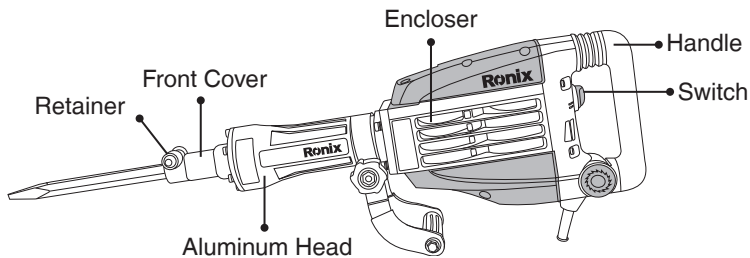

APPLICATION

This hammer should be applied to breaking concrete, chipping off concrete, grooving, bar cutting, and driving piles in installation of piping and wiring, unitary facility installation, machinery installation water supply, and drainage work, interior jobs, harbor facilities and other civil engineering work etc...

SAFETY SYMBOLES

In this operator's manual/or machine's labels following symbols are used



Read the manual carefully



Accordance with essential applicable safety of European directives.



Double insulation



Wear ear and eye protection.



Denote risk of personal injury, loss of life or damage to the tool in case of nonobservance of the instruction in this manual.



Indicate electrical shock hazard.



Immediately unplug the plug from the main electricity in the case that the cord gets damage and during maintenance.



Faulty and /or discarded electrical or electronic apparatus have to be collected at the appropriate recycling location.

GENERAL POWER TOOL SAFETY WARNINGS

WARNING!

Read all safety warnings and all instructions. Failure to follow all warnings and instructions may result in electric shock, fire and/or serious injury.

Save all warnings and instructions for future reference.

The term “power tool” in the warnings refer to your mains operated (corded) power tool or battery operated (cordless) power tool.

■ **WORK AREA SAFETY**

a) Keep work area clean and well lit. Cluttered and dark areas invite accidents.

b) Do not operate power tools in explosive atmospheres, such as in the presence of flammable liquids, gases or dust. Power tools create sparks which may ignite the dust or fumes.

c) Keep children and bystanders away while operating a power tool. Distractions can cause you to lose control.

■ **ELECTRICAL SAFETY**

a) Power tool plugs must match the outlet. Never modify the plug in any way. Do not use any adapter plugs with earthed (grounded) power tools. Unmodified plugs and matching outlets will reduce risk of electric shock.

b) Avoid body contact with earthed or grounded surfaces such as pipes, radiators, ranges and refrigerators. There is an increased risk of electric shock if your body is earthed or grounded.

c) Do not expose power tools to rain or wet conditions. Water entering a power tool will increase the risk of electric shock.

d) Do not abuse the cord. Never use the cord for carrying, pulling or unplugging the power tool. Keep cord away from heat, oil, sharp edges or moving parts. Damaged or entangled cords increase the risk of electric shock.

- e) When operating a power tool outdoors, use an extension cord suitable for outdoor use. Use of a cord suitable for outdoor use reduces the risk of electric shock.
- f) If operating a power tools in a damp location is unavoidable, use a residual current device (RCD) protected supply. Use of an RCD reduces the risk of electric shock.

■ PERSONAL SAFETY

- a) Stay alert, watch what you are doing and use common sense when operating a power tool. Do not use a power tool while you are tired or under the influence of drugs, alcohol or medication. A moment of inattention while operating power tools may result in serious personal injury.
- b) Use personal protective equipment. Always wear eye protection. Protective equipment such as dust mask, non-skid safety shoes, hard hat, or hearing protection used for appropriate conditions will reduce personal injuries.
- c) Prevent unintentional starting. Ensure the switch is in the off-position before connecting to power source, picking up or carrying the tool. Carrying power tools with your finger on the switch or plugging in power tools that have the switch on invites accidents.
- d) Remove any adjusting key or wrench before turning the power tool on. A wrench or a key left attached to a rotating part of the power tool may result in personal injury.
- e) Do not overreach. Keep proper footing and balance at all times. This enables better control of the power tool in unexpected situations.
- f) Dress properly. Do not wear loose clothing or jewelry. Keep your hair, clothing and gloves away from moving parts. Loose clothes, jewelry or long hair can be caught in moving parts.
- g) If devices are provided for the connection of dust extraction and collection facilities, ensure these are connected and properly used. Use of these devices can reduce dust related hazards.

■ POWER TOOL USE AND CARE

- a) Do not force the power tool. Use the correct power tool for your application. The correct power tool will do the job better and safer at the rate for which it was designed.
- b) Do not (use the power tool if the switch does not turn it on and off. Any power tool that cannot be controlled with the switch is dangerous and must be repaired.
- c) Disconnect the plug from the power source before making any adjustments, changing accessories, or storing power tools. Such preventive safety measures reduce the risk of starting the power tool accidentally.
- d) Store idle power tools out of the reach of children and do not allow persons unfamiliar with the power tool or these instructions to operate the power tool. Power tools are dangerous in the hands of untrained users.
- e) Maintain power tools. Check for misalignment or binding of moving parts, breakage of parts and any other condition that may affect the power tool's operation. If damaged, have the power tool repaired before use. Many accidents are caused by poorly maintained power tools.
- f) Keep cutting tools sharp and clean. Properly maintained cutting tools with sharp cutting edges are less likely to bind and are easier to control;
- g) Use the power tool, accessories and tool bits etc., in accordance with these instructions, taking into account the working conditions and the work to be performed. Use of the power tool for operations different from intended could result in a hazardous situation.

■ SERVICE

- a) Have your power tool serviced by a qualified repair person using only identical replacement parts in RONIX PLUS after sales centers. This will ensure that the safety of the power tool is maintained.

ADDITIONAL SAFETY RULES FOR HAMMER

- 1) Wear ear protectors. Exposure to noise can cause hearing loss.
- 2) Use auxiliary handle(s), if supplied with the tool. Loss of control can cause personal injury.
- 3) Hold power tools by insulated gripping surfaces, when performing an operation where the cutting tool may contact hidden wiring or its own cord. Cutting accessory contacting a «live» wire may make exposed metal parts of the power tool «live» and could give the operator an electric shock.
- 4) Wear a dust mask.
- 5) Be sure the bit is secured in place before operation.
- 6) Under normal operation, the machine is designed to produce vibration, the screws and bolts can come loose, causing a breakdown and accidents. Check tightness of them carefully before running.
- 7) In cold weather or a long time tool not be used, please keep the tool running without load a few minutes to warm up the grease inside, otherwise hammering function is difficult to get.
- 8) Be sure you stand stably and no one is below when you using tool is in high location.
- 9) Hold the tool firmly with two hands.
- 10) Don't touch any moving parts.
- 11) Don't leave the tool running itself, operate tool only when hand-held.
- 12) Don't point the tool to anybody for the bit could fly out in case.
- 13) Don't touch the bit or parts close to the bit immediately after operation, they may extremely hot and could burn your skin.
- 14) Any damage and abnormal happen, please stop to use immediately and disconnect it, ask RONIX PLUS authorized service center to check and repair.
- 15) Parts replace: Only original RONIX's parts can be used to replace by authorized service center.
- 16) Right use accessories and parts: Don't use other parts and accessories which not mentioned in the manual otherwise may

cause injuries!

17) Special attention to voltage: Before connect the power tool, please make sure the rated voltage on the tool can match the power supply, otherwise the power tool may be damaged and cause injuries.

18) Don't wipe plastic part with solvent: Solvent such as gasoline, thinner, alcohol etc. these kind of chemical material, are not allowed to use, water or soap are recommended!

19. In case of damages the replacement of the plug or the supply cord shall always be carried out by the manufacturer of the tool or his service organization

PERATION INSTRUCTION

■ PRIOR TO OPERATION:

Read the ENTIRE IMPORTANT SAFETY INFORMATION section at the beginning of this manual including all text under subheadings therein before set up use of these products.

1. POWER SOURCE

Ensure that the power source to be utilized conforms to the power requirements which specified on the name plate of the hammer.

2. POWER SWITCH

Ensure that the power switch is in the position of OFF. If the plug is connected to power receptacle while the power switch is in ON position, the demolition hammer will start operation immediately, which can cause serious accident!

3. EXTENSION CORD

When the work area is removed from the power source, use an extension cord of sufficient thickness and rated capacity. The extension cord should be kept as short as practicable.

SWITCH OPERATING

Observe correct mains voltage! The voltage of the power source must agree with the voltage specified on the type plate of the power tool.

| | | |
|------------|---|---|
| Switch ON | To start the power tool, Press the switch towards arrow "1" direction |  |
| Switch OFF | To switch off the power tool, Press the switch towards arrow "0" direction. | |

For low temperatures, the power tool reaches the full impact rate only after a certain time.

This start-up time can be shortened by striking the chisel in the power tool against the floor one time.

MOUNTING TOOL BITS

WARNING!

Before do it, make sure unplug the machine!

(1) Pull out of the retainer «2», turning 180 clockwise or anticlockwise, insert the accessory shank portion»1« into the hole on the front cover.

(2) Turning the retainer back into original position.

Remarking: When you removing the accessory, such as a bull point, a cutter etc., follow above procedure in reverse order.

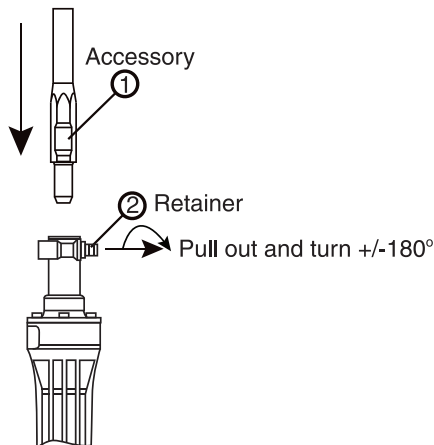

INDICATOR LEDS

The green power-ON indicator LED lights up when the tool is plugged. If indicator led does not light up, the mains cord or the controller may be defective. The red service indicator LED lights up when the carbon brushes are worn out to indicate that the tool needs servicing.

GREASE AND OIL FILLING

WARNING!

Pull plug from power before any operations.

Demolition hammer mechanical part is easy to get worn and lose impact energy if without enough lubrication, recommend filling grease and oil after 6 months usage.

Grease and oil filling should be carried out by RONIX PLUS authorized service agent.

MAINTENANCE AND INSPECTION

BEFORE DO ANY MAINTENANCE, ENSURE UNPLUG THE PLUG.

1. INSPECTING THE TOOL

Since use of a dull tool will degrade efficiency and cause possible motor malfunction, sharpen or replace the tool as soon as abrasion is noted.

2. INSPECTING THE MOUNTING SCREWS

Regularly inspect all mounting screws and ensure that they are properly tightened. Should any of the screws be loose, retighten them immediately. Failure to do so could result in serious hazard.

3. INSPECTING THE BIT RETAINER

The retainer may become loose due to excessive use. Make sure the bit shank position is hold securely, if any wear or damage is found, ask the **RONIX PLUS** authorized service people to maintenance.

4. MAINTENANCE OF THE MOTOR

The motor unit winding is the very “heart” of the power tool. Exercise due care to ensure the winding does not become damaged and/or wet with oil or water.

5. INSPECTING THE CARBON BRUSHES

The Motor employs carbon brushes which are consumable parts. When they become worn to or near the “wear limit”, it could result in motor trouble. The red service indicator LED lights up when the carbon brushes are worn out to indicate that the tool needs servicing. The power tool must then be sent to RONIX PLUS after-sales service agent.

6. CLEANING

Clean the machine regularly with a soft cloth, preferably after each use. Solvent such as gasoline, thinner, alcohol etc...

These kind of chemical materials are not allowed to use, water or soap are recommended!

CAUTION:

Repair, modification and inspection of RONIX Power tools must be carried out by a RONIX PLUS Authorized Service Center. In the operation and maintenance of power tools, the safety regulations and standards prescribed in each country must be observed.

Ronix[®]
Premium Quality

www.ronixtools.com