

Ronix®

Premium Quality

ROTARY HAMMER 28MM

2700

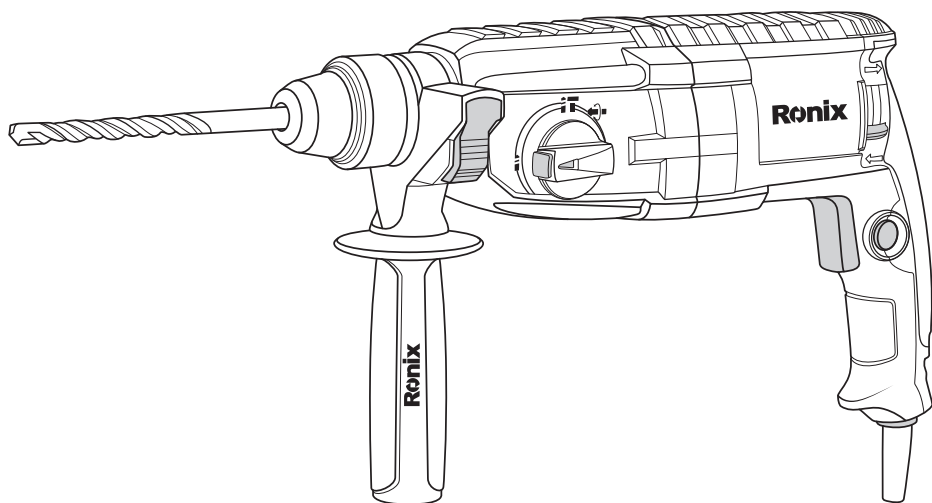

www.ronixtools.com

12
MONTHS
GUARANTY

FREE
DELIVERY

BANK
SPARE PARTS

CALL
CENTER
02161904

PRODUCT SPECIFICATIONS

Model	2700
Power	850W
Voltage	220V
Frequency	50Hz
No Load Speed	0-1280RPM
Impact Rate	0-5500BPM
Impact Energy	3.5J
Max Drilling Capacity	Steel: 13mm Concrete: 28mm Wood: 40 mm
Weight	3Kg
Accessories	Drill bit: 4pcs
	Scale Bar: 1pc
	Carbon Brush: 1pair

PART LIST

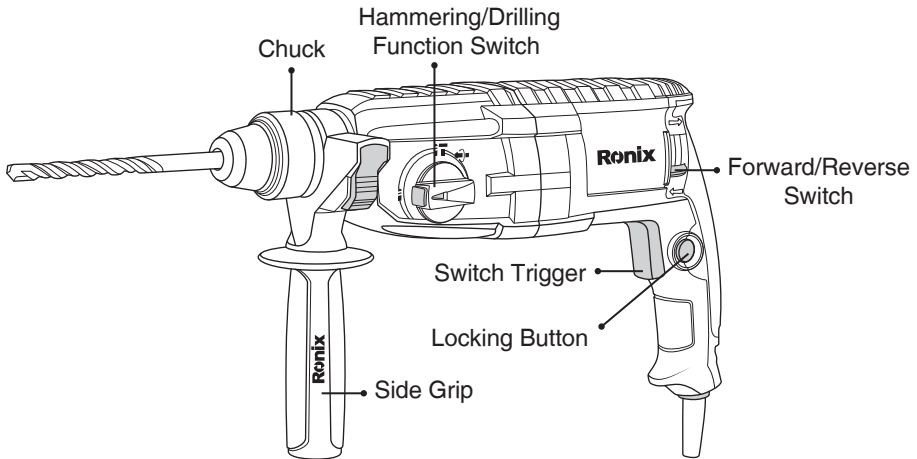

GENERAL SAFETY RULES

WARNING!

Read and understand all instructions. Failure to follow all instructions listed below, may result in electric shock, fire and / or serious personal injury.

■ **WORK AREA**

- 1) keep your work area clean and well lit. Cluttered benches and dark areas invite accidents.
- 2) Do not operate power tools in explosive atmospheres, such as in the presence of flammable liquids, gases, or dust. Power tools create sparks which may ignite the dust or fumes.
- 3) Keep bystanders, children, and visitors away while operating a power tool. Distractions can cause you to lose control.

ELECTRICAL SAFETY

4) Power tool plugs must match the outlet.

Never modify the plugs in any way. Do not use any adapter plugs with earthed power tools. Unmodified plugs and matching outlets will reduce risk of electric shock. Do not change the plug in any way. Double insulation eliminates the need for the three wire grounded power cord and grounded power supply system.

5) Avoid body contact with grounded surfaces such as pipes, radiators, ranges and refrigerators. There is an increased risk of electric shock if your body is grounded.

6) Do not expose power tools to rain or wet conditions. Water entering a power tool will increase the risk of electric shock.

7) Do not abuse the cord. Never use the cord to carry the tools or pull the plug from an outlet. Keep cord away from heat, oil, sharp edges or moving parts. Replace damaged cords immediately. Damaged cord increase the risk of electric shock.

8) When operating a power tool outside, use an outdoor extension cord

marked “W-A” or “W”. These cords are rated for outdoor use and reduce the risk of electric shock.

PERSONAL SAFETY

9) Stay alert, watch what you are doing and use common sense when operating a power tool. Do not use tool while tired or under the influence of drugs, alcohol, or medication. A moment of inattention while operating power tools may result in serious personal injury.

10) Dress properly. Do not wear loose clothing or jewelry. Contain long hair. Keep your hair, clothing, and gloves away from moving parts. Loose clothes, jewelry, or long hair can be caught in moving parts.

11) Avoid accidental starting. Be sure switch is off before plugging in. Carrying tools with your finger on the switch or plugging in tools that have the switch on invites accidents.

12) Remove adjusting keys or wrenches before turning the tool on. A wrench or a key that is left attached to a rotating part of the tool may result in personal injury.

13) Do not overreach. Keep proper footing and balance at all times. Proper footing and balance enables better control of the tool in unexpected situations.

14) Use safety equipment. Always wear eye protection. Oust mask, non-skid safety shoes, hard hat, or hearing protection must be used for appropriate conditions. Ordinary eye or sun glasses are NOT eye protection.

TOOL USE AND CARE

15) Use clamps or other practical way to secure and support the workpiece to a stable platform. Holding the work by hand or against your body is unstable and may lead to loss of control.

16) Do not force tool. Use the correct tool for your application. The correct tool will do the job better and safer at the rate for which it is designed.

17) Do not use tool if switch docs not turn It on or off. Any tool that cannot be controlled with the switch is dangerous and must be repaired.

18) Disconnect the plug from the power source before making any adjustments, changing accessories, or storing the tool. Such preventive safety measures reduce the risk of starting the tool accidentally.

19) Store idle tools out of reach of children and other untrained persons. Tools are dangerous in the hands of untrained users.

20) Maintain tools with care. Keep cutting tools sharp and clean. Properly maintained tools with sharp cutting edges are less likely to bind and are easier to control.

21) Check for misalignment or binding of moving parts, breakage of parts, and any other condition that may affect the tools operation. If damaged, have the tool serviced before using. Many accidents are caused by poorly maintained tools.

22) Use only accessories that are recommended by the manufacturer for your model. Accessories that may be suitable for one tool, may become hazardous when used on another tool.

SERVICE

23) Tool service must be performed only by qualified repair personnel. Service or maintenance performed by unqualified personnel could result in a risk of injury.

24) When servicing a tool, use only identical replacement parts. Follow instructions in the Maintenance section of the manual. Use of unauthorized parts or failure to follow Maintenance instructions may create a risk of electric shock or injury.

SPECIFIC SAFETY RULES

DO NOT let comfort or familiarity with product (gained from repeated use) replace strict adherence to rotary hammer safety rules. If you use this tool unsafely or incorrectly, you can suffer serious personal injury.

1) Hold tool by insulated gripping surfaces when performing an operation where the cutting tools may contact hidden wiring or its own cord. Contact with a “live” wire will make exposed metal parts of the tool “live” and

shock the operator.

- 2) Always be sure you have a firm footing. Be sure no one is below when using the tool in high locations.
- 3) Hold the tool firmly.
- 4) Keep hands away from rotating parts.
- 5) Do not leave the tool running. Operate the tool only when hand-held.
- 6) Do not touch the drill bit or the workpiece immediately after operation; they may be extremely hot and could burn your skin.
- 7) Wear ear protectors when using the tool for extended periods. Prolonged exposure to high intensity noise can cause hearing loss.
- 8) Wear a hard hat (safety helmet), safety glasses and/or face shield. Ordinary eye or sun glasses are NOT safety glasses. It is also highly recommended that you wear a dust mask and thickly padded gloves.
- 9) Be sure the bit is secured in place before operation.
- 10) Under normal operation, the tool is designed to produce vibration. The screws can come loose easily, causing a breakdown or accident. Check tightness of screws carefully before operation.
- 11) In cold weather or when the tool has not been used for a long time, let the tool warm up for a while by operating it under no load. This will loosen up the lubrication. Without proper warm-up, hammering operation is difficult.
- 12) Do not point the tool at any one in the area when operating. The bit could fly out and injure someone seriously.
- 13) Some material contains chemicals which may be toxic. Take caution to prevent dust inhalation and skin contact. Follow material supplier safety data.
- 14) The tool designed safe clutch equipment, please turn off the machine when the clutch connection.

The following show the symbols used for the tool.

v	voltage
n	no load speed
A	amper
--/min	revolutions reciprocation per minute
Hz	hertz

1) USING INSTRUCTIONS INSTALL OR REMOVE DRILL BIT

⚠ CAUTION:

Please unplug the machine before installing or removing drill bit.

Coat a little grease at the connecting end of the drill bit, press down the chuck then insert the connecting end into the chuck hole and release hand from the chuck. After inserting, make sure the drill bit can move axially but locked well and cannot be taken out from the chuck. If you want to remove the drill bit, please press down the chuck then take out the drill bit.

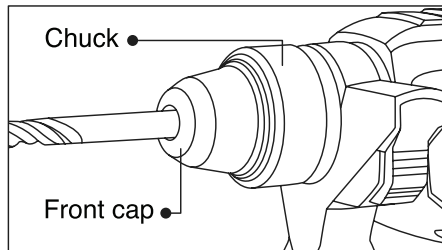

2) INSTALL OR REMOVE SIDE GRIP

The side grip has been installed on the machine inside the box. If you want to adjust the angle of side grip, please swivel the grip anticlockwise to loosen it and turn to the desired angle, then swivel it clockwise.

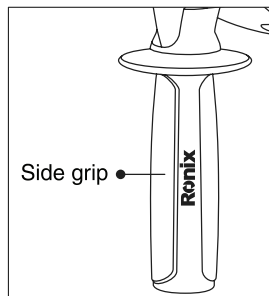

3) ADJUST DEPTH RULER

In the grip base, there is a hole for the depth ruler. Press down the button, insert the depth ruler and move it to desired depth, then release the button to secure it.

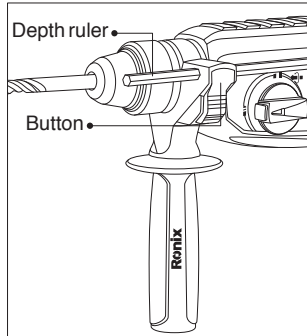

4) FORWAED / REVERSE SWITCH

When on/off switch trigger released, then the machine is off. Shift the Forward/Reverse switch to forward or reverse drilling.

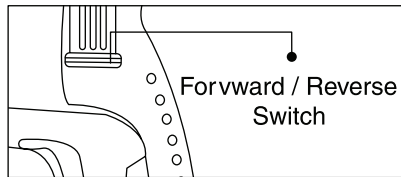

5) HAMMERING AND DRILLING FUNCION

Press down the small knob and turn the big knob till the “ ” to “ ” and release the small knob, then it is for drilling function only. Press down the small knob and turn the big knob till the “△” to “ ” and release the small knob, then it “△” is “ ” for drilling/hammering function. Press down the small knob and turn the big knob till the “△” to “ ” and release the small knob, then it is for hammering function only.

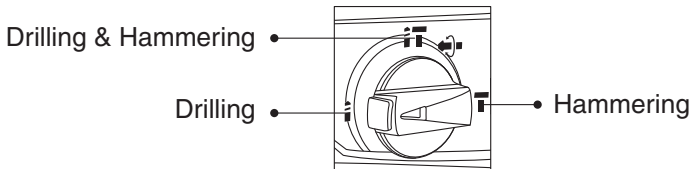

6) ON / OFF SWITCH

Press down the trigger, then the machine is on. Release the trigger, then the machine is off.

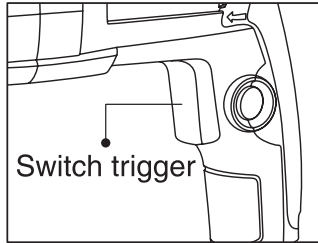

MAINTENANCE & DAILY CARE

⚠ CAUTION:

Always be sure that the tool is switch off and unplugging before attempting to perform inspection and maintenance.

- 1) The tool and its air vents have to be keep clean, regularly clean the tool's air vents or whenever the vents start to become obstructed.
- 2) Check the all screws if loosened or not periodically.
- 3) Check the cord insulation if broken or not.

⚠ CAUTION:

Be sure to re-install the knob after inserting new carbon brush.

After replacing brushes, plug in the tool break in brushes by running tool with no load for about ten minutes. Then check the tool while running, when releasing the switch trigger. If the tool is not working well, ask your local Ronix service center for repair.

To maintain product **SAFETY** and **RELIABILITY**, repairs, and other maintenance or adjustment should be performed by **RONIX** Authorized or Factory service centers, always using **RONIX** replacement parts.

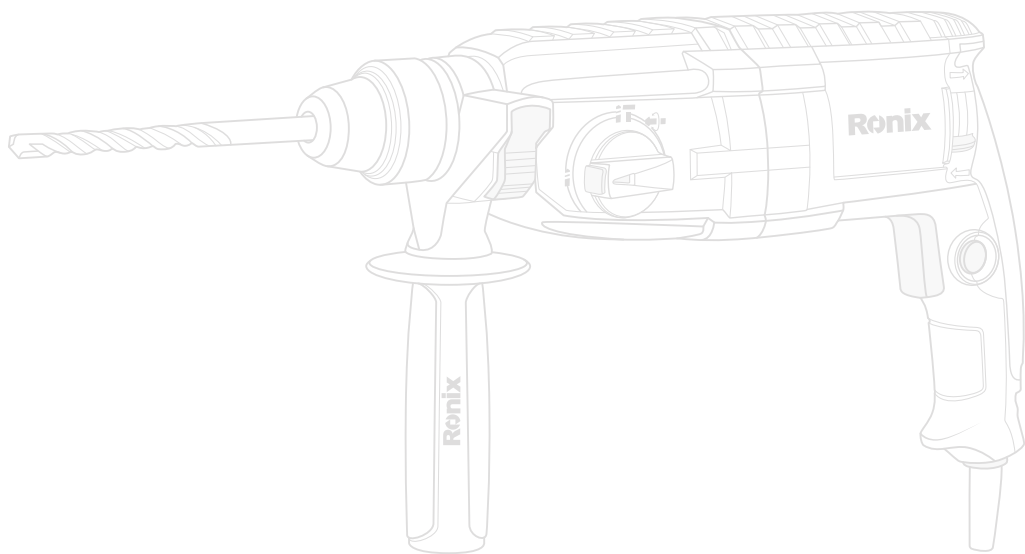

Ronix[®]
Premium Quality

www.ronixtools.com