

# Ronix<sup>®</sup>

Premium Quality

## ELECTRIC DRILL PRESS 350W 2603

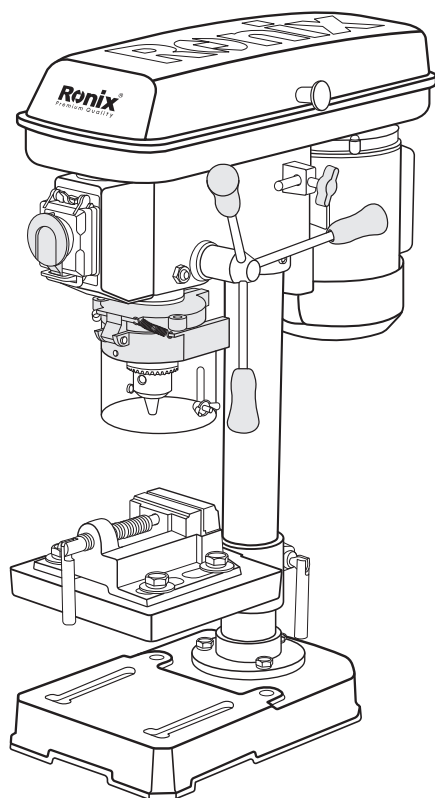

# SPECIFICATIONS

Model	2603
Voltage	220-240V
Power	350W
Chuck Capacity	1.5-13mm
Drill Capacity	Steel:13mm Wood: 20mm Plastic 16mm
Spindle Travel	50mm
Class Of Speed	5
Speed	620-2620RPM
Spindle Taper	B16
Distance from spindle axis to the column	105mm
Distance from spindle end to the surface of table	220mm
Distance from spindle end to the surface of base	300mm
Swing	210mm
Table Size	160×160mm
Base Size	290×190mm
Column Diameter	46mm
Height	580mm
Net Weight/Gross Weight	15.5Kg

<b>Accessories</b>	
SPRING WASHER 8	3
OUTSIDE HEX. BOLT M8x20	3
HANDLE & TIP	3
HEXAGON BAR WRENCH 3	1
HEXAGON BAR WRENCH 4	1
CROSS RECESS PAN HD SCREW M5	1
FLAT WASHER M5	1
PULLEY COVER TIP	1
CHUCK	1
CHUCK GUARD	1
OUTSIDE HEX. BOLT M10x35	4
BENCH VICE 2.5"	1
FLAT WASHER 10	8
NUT M10	4

## PARTS LIST

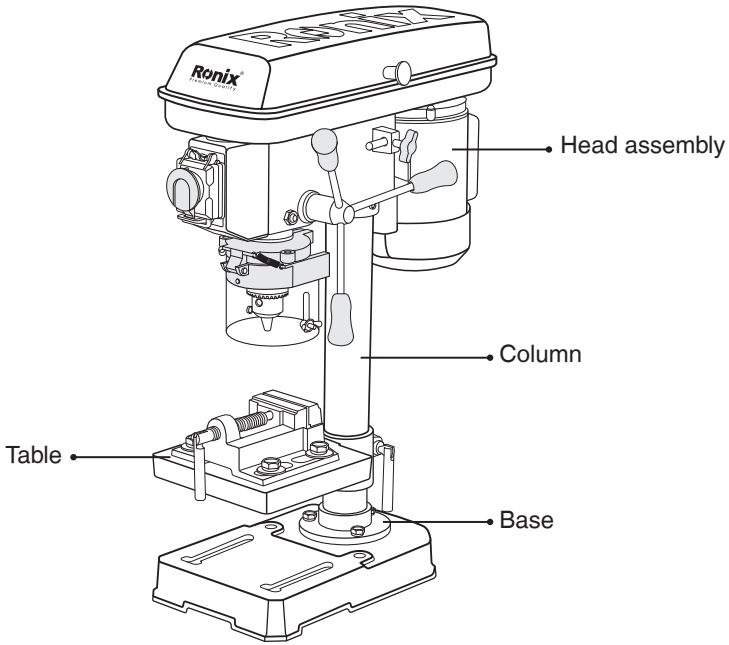

## SPECIFICATIONS

### **WARNING!**

To avoid electrical hazards, fire hazards, or damage to the tool, use proper circuit protection.

Use a separate electrical circuit for your tools. To avoid shock or fire, replace power cord immediately if it is worn, cut or damaged in any way.

### **WARNING!**

To avoid mistakes that could cause serious injury, do not plug the Drill Press in until you have read and understood the following.

1- **READ** and become familiar with the entire Operator's Manual. **LEARN** the tool's application, limitations and possible hazards.

2- **KEEP GUARDS IN PLACE** and in working order.

3- **REMOVE ADJUSTING KEYS AND WRENCHES.** Form a habit of checking to see that keys and adjusting wrenches are removed from the tool before turning ON.

4- **KEEP WORK AREA CLEAN.** Cluttered areas and benches invite accidents.

5- **DON'T USE IN DANGEROUS ENVIRONMENT.** Don't use power tools in damp or wet locations, or expose them to rain. Keep work area well lighted.

6- **KEEP CHILDREN AWAY.** All visitors should be kept at a safe distance from work area.

7- **MAKE WORKSHOP CHILDPROOF** with padlocks.

8- **DON'T FORCE THE TOOL.** It will do the job better and safer at the rate for which it was designed.

9- **USE THE RIGHT TOOL.** Do not force tool or attachment to do a job for which it was not designed.

10- **USE PROPER EXTENSION CORD.** Make sure your extension cord is in good condition. When using an extension cord, be sure to use one heavy enough to carry the current your product will draw. An undersized cord will result in a drop in line voltage and in loss of power that will

cause the tool to overheat.

11- WEAR PROPER APPAREL. Do not wear loose clothing, gloves, neckties, rings, bracelets, or other jewelry that may get caught in moving parts. Non-slip footwear is recommended. Wear protective hair covering to contain long hair.

12- ALWAYS WEAR EYE PROTECTION. Any Drill Press can throw foreign objects into the eyes that could cause permanent eye damage. ALWAYS wear Safety Goggles (not glasses). Everyday eyeglasses have only impact-resistance lenses. They ARE NOT safety glasses.

13- SECURE WORK. Use clamps or a vise to hold work when practical. It's safer than using your hand and it frees both hands to operate tool.

14- DISCONNECT TOOLS before servicing; when changing accessories such as blades, bits, cutters, and the like.

15- REDUCE THE RISK OF UNINTENTIONAL STARTING. Make sure switch is in OFF position before plugging in.

16- USE RECOMMENDED ACCESSORIES. Consult the Operator's Manual for recommended accessories. The use of improper accessories may cause serious injury.

17- NEVER STAND ON TOOL. Serious injury could occur if the tool is tipped or if the cutting tool is unintentionally contacted.

18- CHECK FOR DAMAGED PARTS. Before further use of the tool, a guard or other part that is damaged should be carefully checked to determine that it will operate properly and perform its intended function – check for alignment of moving parts, binding of moving parts, breakage of parts, mounting, and any other conditions that may affect its operation. A guard or other part that is damaged should be properly repaired or replaced.

19- NEVER LEAVE TOOL RUNNING UNATTENDED. TURN POWER "OFF". Don't leave tool until it comes to a complete stop.

20- DON'T OVERREACH. Keep proper footing and balance at all times.

21- MAINTAIN TOOLS WITH CARE. Keep tools sharp and clean

for best and safest performance. Follow instructions for lubricating and changing accessories.

22- Do not use power tools in the presence of flammable liquids or gases.

### **SAFETY**

23- **DO NOT OPERATE** the tool if you are under the influence of any drugs, alcohol or medication that could affect your ability to use the tool properly.

24- **ALWAYS** operate the Drill Press in a well-ventilated area and provide for proper dust removal. Use dust collection systems whenever possible. Dust generated from certain materials can be hazardous to your health.

## **SPECIFIC SAFETY INSTRUCTIONS**

### **WARNING!**

For your own safety, do not try to use your drill press or plug it in until it is completely assembled and installed according to the instructions, and until you have read and understood this instruction manual.

- 1- **THIS DRILL PRESS** is intended for use in dry conditions, indoor use only.
- 2- **WEAR EYE PROTECTION.** USE a face or dust mask along with safety goggles if drilling operation is dusty. USE ear protectors, especially during extended periods of operation.
- 3- **DO NOT** wear gloves, neckties, or loose clothing.
- 4- **DO NOT** try to drill material too small to be securely held.
- 5- **ALWAYS** keep hands out of the path of a drill bit. Avoid awkward hand positions where a sudden slip could cause your hand to move into the drill bit.
- 6- **DO NOT** install or use any drill bit that exceeds 175mm in length or extends 150mm below the chuck jaws. They can suddenly bend outward or break.
- 7- **DO NOT USE** wire wheels, router bits, shaper cutters, circle (fly) cutters, or rotary planers on this drill press.
- 8- **WHEN** cutting a large piece of material, make sure it is fully supported at the table height.

9- DO NOT perform any operation freehand. ALWAYS hold the work piece firmly against the table so it will not rock or twist. Use clamps or a vise for unstable work pieces.

10- MAKE SURE there are no nails or foreign objects in the part of the work piece to be drilled.

11- CLAMP THE WORKPIECE OR BRACE IT against the left side of the column to prevent rotation. If it is too short or the table is tilted, clamp it solidly to the table.

12- IF THE WORKPIECE overhangs the table such that it will fall or tip if not held, clamp it to the table or provide auxiliary support.

13- SECURE THE WORK. Use clamps or a vise to hold the work when practical. It's safer than using your hand and it frees both hands to operate tool.

14- MAKE SURE all clamps and locks are firmly tightened before drilling.

15- SECURELY LOCK THE HEAD and table support to the column, and the table to the table support before operating the drill press.

16- NEVER turn your drill press ON before clearing the table of all objects (tools, scraps of wood, etc.).

17- BEFORE STARTING the operation, jog the motor switch to make sure the drill bit does not wobble or vibrate.

18- LET THE SPINDLE REACH FULL SPEED before starting to drill. If your drill press makes an unfamiliar noise or if it vibrates excessively, stop immediately, turn the drill press OFF and unplug. Do not restart the unit until the problem is corrected.

19- DO NOT perform layout assembly or set up work on the table while the drill press is in operation.

20- USE THE RECOMMENDED SPEED for any drill press accessory and for different work piece material.

21- WHEN DRILLING large diameter holes, clamp the work piece firmly to the table. Otherwise, the bit may grab and spin the work piece at high speeds. DO NOT USE fly cutters or multiple-part hold cutters, as they can come apart or become unbalanced in use.

22- MAKE SURE the spindle has come to a complete stop before

touching the work piece.

23- TO AVOID INJURY from accidental starting, always turn the switch OFF and unplug the drill press before installing or removing any accessory or attachment or making any adjustment.

**▲ NOTE:**

**USE PROPER EXTENSION CORD.** Make sure your extension cord is in good condition. When using an extension cord, be sure to use one heavy enough to carry the current your product will draw. An undersized cord will cause a drop in line voltage, resulting in loss of power and cause overheating.

Be sure your extension cord is properly wired and in good condition. Always replace a damaged extension cord or have it repaired by a qualified person before using it.

Protect your extension cords from sharp objects, excessive heat and damp or wet areas.

## **ASSEMBLY**

### **■ COLUMN SUPPORT TO BASE (FIG 1)**

- Position the base on floor or bench.
- Place the column on the base, aligning the holes in the column support with the holes in the base.
- Locate the four long hex bolts from the loose parts bag.
- Place a bolt in each hole through the column support and the base. Tighten with an adjustable wrench.

### **■ INSTALL TABLE (FIG 2)**

Slide table assembly over column.

### **■ TIGHTEN TABLE BRACKET LOCKING HANDLE TO SECURE TABLE ASSEMBLY. (FIG 3)**



#### ■ **INSTALLING THE HEAD (FIG 4)**

- Carefully lift the head above the column and slide it onto the column. Make sure the head slides down over the column as far as possible. Align the head with the base.
- Using the hex wrench, tighten the head lock set screws.

#### ■ **INSTALLING FEED HANDLES (FIG 5)**

Locate the three feed handles in the loose parts bag.

- Screw the feed handles into the threaded holes in the hub. Tighten.

#### ■ **INSTALLING THE CHUCK (FIG 6)**

##### **WARNING!**

Before any assembly of the chuck and arbor to the drill press head, clean all mating surfaces with a non-petroleum based product; such as alcohol or lacquer thinner. Any oil or grease used in the packing of these parts must be removed; otherwise the chuck may come loose during operation.

- Open the jaws of the chuck by rotating the chuck sleeve clockwise. To prevent damage, make sure the jaws are completely retracted into the chuck.
- Push the chuck onto the spindle.

##### **ATTENTION:**

Clean the spindle taper with a non-alcohol based cleaner before inserting it into the chuck.

- Using a wood mallet, firmly tap the chuck upward into position on the spindle shaft.

## ■ INSTALL KNOB AND SCREW OF UPPER PULLEY COVER. (FIG 7)

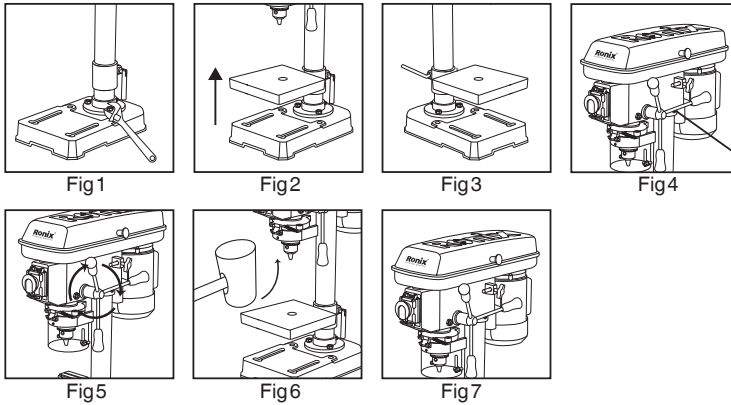

## ADJUSTMENT

### ■ TABLE ADJUSTMENT

A. Tilting adjustment:

Loosen lock bolt then swing table to appropriate position and retighten lock bolt.

B. Swing 360°

Loosen table bracket locking handle then swing table to appropriate position and retighten the locking handle.

C. The scale of down shows work table's degrees rotation

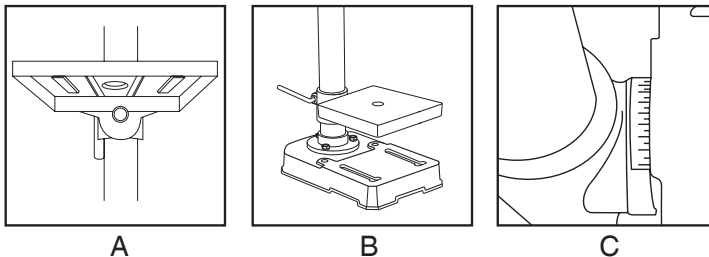

### ■ SPEED ADJUSTMENT (FIG 1)

- This drill press has 5 speeds shown in the speed label.
- To change the speed, loose the belt tension lock knob , pull the motor mounting plate to the front end then change the belt location.
- To tighten the belt, push the motor mounting plate to the rear end and lock the belt tension lock knob.

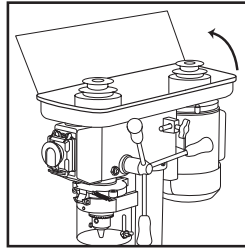

Fig1

## OPEARTIONS

### ■ INSTALLING A DRILL BIT (FIG 1)

- With the switch “OFF”, open the chuck jaws (1) using the chuck key (2). Turn the chuck key counterclockwise to open the chuck jaws (1).
- Insert the drill bit (3) into the chuck far enough to obtain maximum gripping by the jaws, but not far enough to touch the spiral grooves (flutes) of the drill bit when the jaws are tightened.
- Make sure that the drill is centered in the chuck.
- Turn the chuck key clockwise to tighten the jaws.

### ▲ WARNING!

To avoid injury or accident by the chuck key ejecting forcibly from the chuck when the power is turned ON, always recheck and remove the chuck key before turning the power ON.

### ■ POSITIONING WORK PIECE (FIG 2)

To prevent the work piece or back-up material from being torn from your

hands while drilling, you **MUST** position it against the **LEFT** side of the column. Failure to do this could result in personal injury.

### ■ USING VISE (FIG 3)

For small work piece that cannot be clamped to the table, use a drill press vise. The vise must be clamped or bolted to the table.

### ▲ WARNING!

The drill press vise **MUST** be clamped or bolted to the table to avoid injury from a spinning work piece, or damaged vise or bit parts.

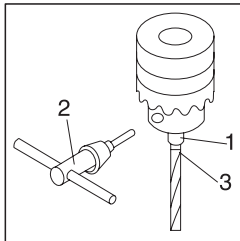

Fig1

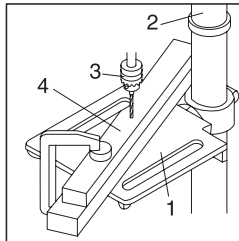

Fig2

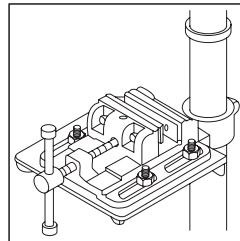

Fig3

### ■ CORRECT DRILLING SPEEDS

### ▲ WARNING!

Be sure drill press is turned off and is disconnected from power source before adjusting speeds.

Use the recommended speed for the drill bit and work piece. The drill bits that can be used is shown in following figure.

Material						
	SOFTWOOD	HARDWOOD	ACRYLIC	BRASS	ALUMINUM	STEEL
<b>TWIST DRILL BITS</b>						
1/16-3/16" (3-5mm)	3000	3000	2500	3000	3000	3000
1/4-3/8" (6-10mm)	3000	1500	2000	1200	2500	1000
7/16-5/8" (11-16mm)	1500	750	1500	750	1500	600
11/16-1" (11-25mm)	750	500	NR	400	1000	250
<b>BRAD-POINT BITS</b>						
1/8"	1800	1200	1500	NR	NR	NR
1/4"	1800	1000	1500	NR	NR	NR
3/8"	1800	750	1500	NR	NR	NR
1/2"	1800	750	1000	NR	NR	NR
5/8"	1800	500	750	NR	NR	NR
3/4"	1400	250	750	NR	NR	NR
7/8"	1200	250	500	NR	NR	NR
1"	1000	250	200	NR	NR	NR
<b>FORSTNER BITS</b>						
1/4-3/8"	2400	700	250	NR	NR	NR
1/2-5/8"	2400	500	250	NR	NR	NR
3/4-1"	1500	500	250	NR	NR	NR
1 1/8-1 1/4"	1000	250	250	NR	NR	NR
1 3/8-2"	500	250	NR	NR	NR	NR
<b>SPADE BITS</b>						
1/4-1/2"	2000	1500	NR	NR	NR	NR
5/8-1 1/2"	1750	1500	NR	NR	NR	NR
1 1/8-1 1/2"	1500	1000	NR	NR	NR	NR
<b>SPADE BITS WITH SPURS</b>						
3/8-1 NR	2000	1800	500	NR	NR	NR

## MAINTENANCE

### **WARNING!**

For our own safety, turn the switch OFF and remove the plug from the power source outlet before maintaining or lubricating your drill press.

Frequently blow out, using an air compressor or dust vacuum, any dust that accumulates inside the motor. A coat of paste wax applied to the table and column will help to keep the surface clean & help avoid rust. To avoid shock or fire hazard, if the power cord is worn or cut on any way, have it replaced immediately.

## LUBRICATION

All of the drill press ball bearings are packed with grease at the factory. They require no further lubrication. Lower spindle to maximum depth and oil moderately once every three months.

## TROUBLESHOOTING CHART

Symptom	Possible Cause(s)	Corrective Action
Noisy operation	1. Incorrect belt tension	1. Adjust tension
	Bit burns or smokes	2. Lubricate spindle
	Excessive drill bit run out or wobble	3. Tighten pulley nut
	Drill bit binds in work piece	4. Tighten set screw in pulley
Bit burns or smokes	1. Incorrect speed	1. Change speed
	2. Retract bit frequently to clear chips	2. Retract bit frequently to clear chips
	3. Sharpen or replace bit	3. Sharpen or replace bit
Excessive drill bit run out or wobble	1. Bent bit	1. Replace bit
	2. Install bit properly	2. Install bit properly
	3. Install chuck properly	3. Install chuck properly
	4. Replace bearings	4. Replace bearings
Drill bit binds in work piece	1. Work piece pinching bit or	1. Support or clamp work piece, decrease feed pressure
	2. Adjust tension	2. Adjust tension
	1. Support or clamp work piece properly	1. Support or clamp work piece properly
Work piece torn loose from hand	1. No supported or clamped properly	



**Ronix**<sup>®</sup>  
Premium Quality