

# Ronix<sup>®</sup>

Premium Quality

## SPRAY GUN

### 1335

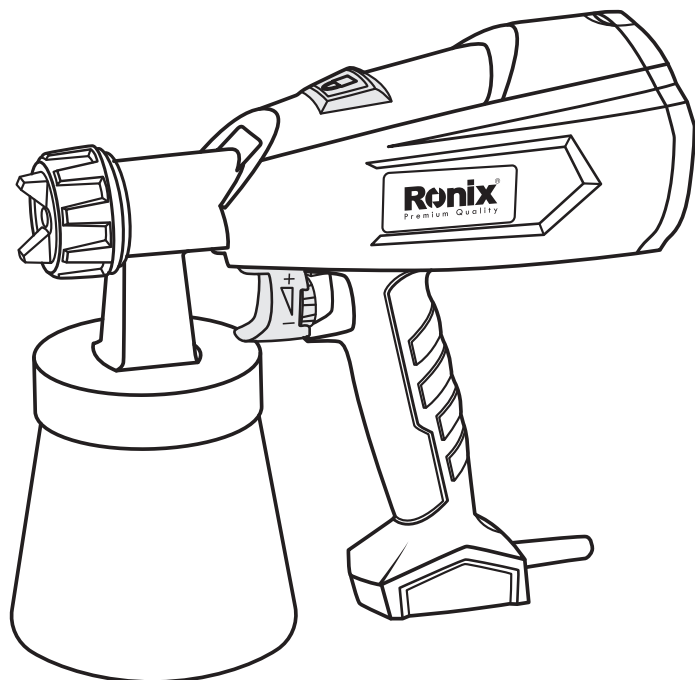

## SPECIFICATIONS

Model	1335
Power	350W
Frequency	50Hz
Voltage	220V
Paint Reservoir	700ml
Max. Viscosity	60din/sec
Max. Flow	700ml/min
Nozzle	1.8mm, 2.6mm
Weight	2kg
Accessories	(1) Viscosity measuring cup, (1) 2.6mm nozzle

## PARTS LIST

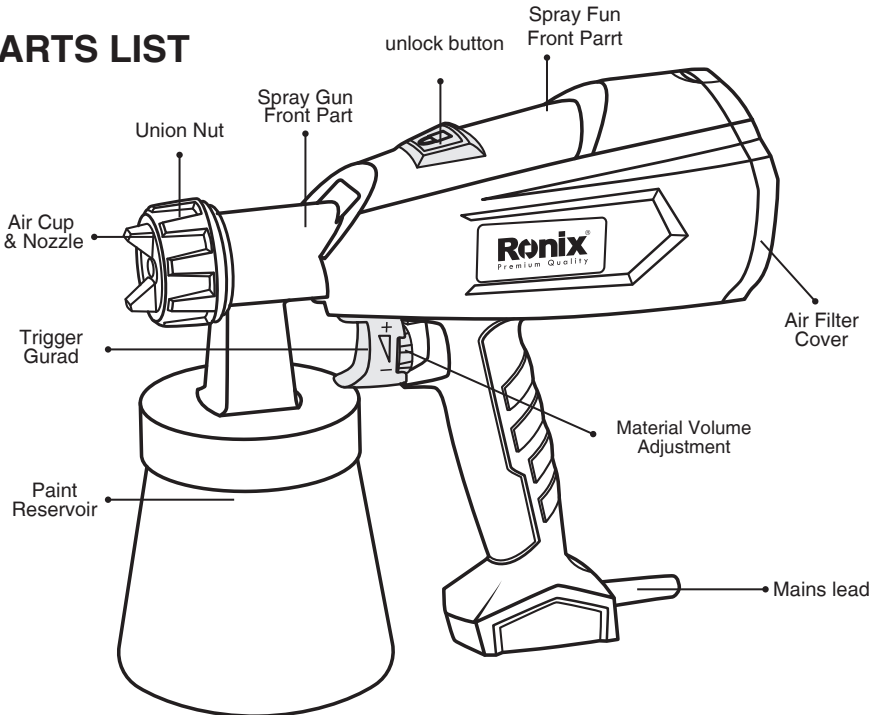

Read the operating instructions carefully before using the tool and observe the safety instructions. Keep the operating instructions in a safe place.

## ■ GENERAL SAFETY INSTRUCTIONS

### **WARNING!**

When using electric tools, basic safety followed to reduce the risk of fire, electric shock and personal injury.

Read all these instructions before operating this product and save these instructions. For safe operations:

- 1) Keep work area clean
  - Cluttered areas and benches invite injuries.
- 2) Consider work area environment.
  - Do not expose power tools to rain. Do not use power tools in damp or wet locations. Keep work area well lit. do not use power tools where there is risk to cause fire or explosion.
- 3) Guard against electric shock.
  - Avoid body contact with earthed or grounded surfaces (e.g. pipes, radiators, ranges, refrigerators).
- 4) Keep children away.
  - Do not let visitors touch the tool or extension cord. All visitors should be kept away from area.
- 5) Store idle tools.
  - When not in use, tools should be stored in a dry, high or locked up place, out of reach of children.
- 6) Do not force the tool.
  - It will do the job better and safer at the rate for which it was intended.
- 7) Use the right tool.
  - Do not force small tools or attachments to do the job of a heavy duty tool. do not use circular saws to cut tree limbs or logs.
- 8) Dress properly.
  - Do not wear loose clothing or jewelry; they can be caught in moving parts.

Rubber gloves and non-skid footwear are recommended when working out doors. Wear protecting hair covering to contain long hair.

9) Use safety glasses.

10) connect dust extraction equipment.

- if devices are provided for the connection of dust extraction and collection facilities ensure these are connected and properly used.

11) Do not abuse the cord.

- Never carry the tool by the cord or yank it to disconnect it from the socket, keep the cord away from heat, oil and sharp edges.

12) Secure work.

- Use clamps or a vice to hold the work. It is safer than using your hand and it frees both hands to operate the tool.

13) Do not overreach.

- Keep proper footing and balance at all times

14) Maintain tool with care.

- Keep cutting tools sharp and clean for better and safer performance.

Follow instructions for lubrication and changing accessories, inspect tool cord periodically and if damaged have it repaired by an authorized service facility.

Inspect extension cords periodically and replace, if damaged. Keep handles dry,

Clean and free from oil and grease

15) Disconnect tools.

- When not in use, before servicing and when changing accessories such as blades, bits and cutters.

16) Remove adjusting keys and wrenches.

- From the habit of checking to see that keys and adjusting wrenches are removed from the tool before turning it on.

17) Avoid unintentional starting.

- Do not carry a plugged-in tool with a finger on the switch. Ensure switch, is off when plugging in.

18) Use outdoor extension leads.

- When tool is used outdoors, use only extension cords intended for

outdoor use.

19) Stay alert.

- Watch what you are doing, use common sense. Do not operate tool when you are tired.

20) Check damaged parts.

- Better further use of the tool, a guard or other part that is damaged should be carefully checked to determine that it would operate properly and perform its intended function. Check for alignment of moving parts, free running of moving parts, breakage of parts, mounting and any other conditions that may affect its operational. A guard or other part char is damaged could be properly repaired or replaced by an authorized service center unless otherwise indicated in this instruction manual. Have defective switches replaced by an authorized service facility. Do not use the tool if the switch does not turn it on and off.

21) Warning.

- The use of any accessory or attachment, other than those recommended, in this instruction manual, may present a risk of personal injury.

22) Have your tool repaired by a qualified person.

- This electric tool is in accordance with the relevant safety requirements. Repairs should only be carried out by qualified persons using original spare parts, otherwise this may result in considerable danger to the user.

#### ■ Safety instructions for Spray Guns

- You may only spray coating materials such as paints, varnishes, glazes, etc. with a flashpoint of 21C (32C in UK) and higher without additional warning. (German classification of coating material is hazard classes A II and A III, see material tin.)

- The device may not be used in workplaces covered by the explosion-protection regulations.

- There must be no sources of ignition such as, for example, open fires, smoke of lit cigarettes, cigars and tobacco pipes, sparks, glowing wires, hot surfaces, etc. in the vicinity during spraying.
- Do not spray any substances whose hazard potential is not known.
- Before working on the spray gun remove the power plug from the socket.
- Do not use the spray guns to spray flammable substances.
- The spray guns are not to be cleaned with flammable solvents which have a flashpoint under 21C.
- Caution against dangers that can arise from the sprayed substance and observe the text and information on the containers or the specifications given by the substance manufacturer.

Recommendation: Wear a breathing mask and safety glasses when spraying.

 **RECOMMENDATION!**

Wear a breathing mask and safety glasses when spraying.

 **CAUTION:**

**DANGER OF INJURY!**

Never point the spray gun at yourself, at other people or at animals.

- When working with the tool indoors as well as outdoors ensures that no solvent vapors are sucked in by the spray gun.
- When working outdoors, be aware of the wind direction. Wind can carry the coating substance across greater distances – thus causing damage. When working indoors, provide for adequate ventilation.
- Do not let children handle the device.
- Never open the device yourself in order to carry out repairs in the electrical system!
- Do not lay the spray gun.

## ■ RESIDUAL RISKS

Even when the power tool is used as prescribed it is not possible to eliminate all residual risk factors. The following hazards may arise in connection with the power tool's construction and design:

1. Damage to lungs if an effective dust mask is not worn.
2. Damage to hearing if effective hearing protection is not worn.
3. Damages to health resulting from vibration emission if the power tool is being used over longer period of time or not adequately managed and properly maintained.

## **WARNING!**

This power tool produces an electromagnetic field during operation. This field may under some circumstances interfere with active or passive medical implants. To reduce the risk of serious or fatal injury, we recommend persons with medical implants to consult their physician and the medical implant manufacturer before operating this machine.

Wear hearing protection while operating the power tool.

The declared vibration total value has been measured in accordance with a standard test method and may be used for comparing one tool with another.

The declared vibration total value may also be used in a preliminary assessment of exposure.

## **WARNING!**

The vibration emission during actual use of the power tool can differ from the declared total value depending on the ways in which the tool is used.

There is the need to identify safety measures to protect the operator that are based on an estimation of exposure in the actual conditions of use (taking account of all parts of the operating cycle such as the times when the tool is switched off and when it is running idle in addition to the trigger time).

## ■ COATING MATERIALS SUITABLE FOR USE

Water – and solvent – based paints, finishes, primers, 2-component paints, clear

finishes, automotive finishes, staining sealers and wood sealer – preservatives.

**■ COATING MATERIALS SUITABLE FOR USE**

Wall paints (emulsion paints) etc., alkali and acidic paints. Coating materials with a flash point below 21C.

**■ PREPARATION OF THE COATING MATERIAL**

The enclosed spray attachment can be used to spray paints, varnishes and glazes that are undiluted or slightly diluted.

1. Stir the material up and put the required amount into the paint container

Thinning Recommendation	
Sprayed material	Undiluted
Glazes	Undiluted
Wood preservatives, mordants, oils, disinfection agents, plant protective agents	Dilute by %10-5

2. If the convey capacity is too low, add %10-5 dilution step-by-step until the convey capacity fulfills your requirements.

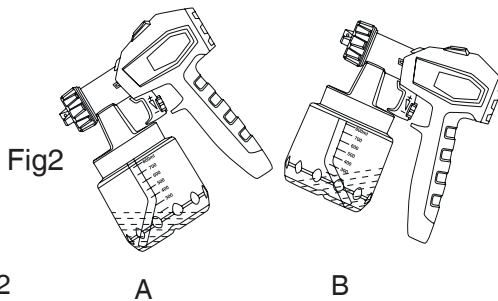



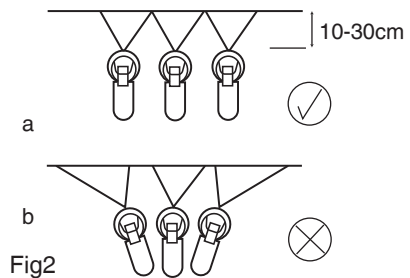
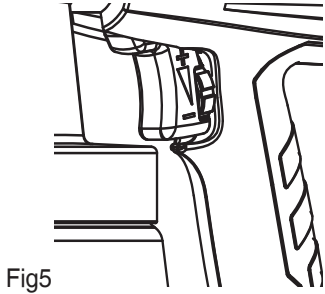
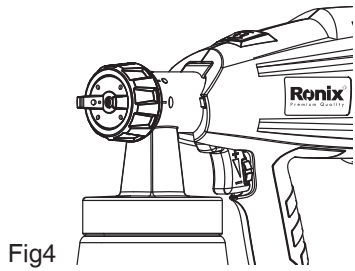
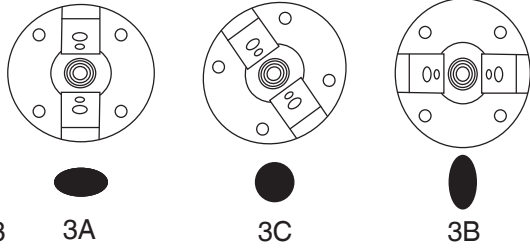

## START – UP

Before connecting to the mains supply, be sure that the supply voltage is identical with the value given on the rating plate.

- Unscrew the container from the spray gun.
- Aligning suction tube. (Fig.2)

If the suction tube is positioned correctly, the container content can be sprayed without almost any residue.

When working on lying objects: Turn the suction tube forwards. (Fig. 2 A)

Spraying work when working on overhead objects: turn the suction tube rearwards. (Fig. 2 B)

- Set the container on a sheet of paper, pour in the prepared coating material and screw the container tightly onto the spray gun.
- Put the machine down only on a level, clean surface. Otherwise the machine could tip over!
- Adjust the spray setting on the spray gun.

Three different spray jet settings can be chosen on the spray gun, depending on the application and target object.

Selecting the spray setting

Fig. 3 A= horizontal fat jet

Fig. 3 B= vertical fat jet

Fig. 3 C= circular jet

The spray pattern indication can be found on the front part of the sprayer. With the arrowhead towards the boss on the tip.

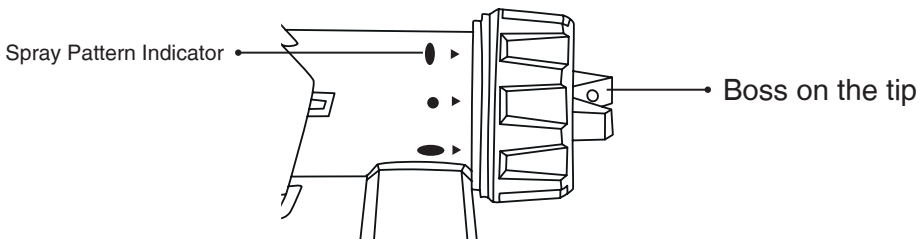

#### ■ ADJUSTING THE DESIRED SPRAY SETTING (FIG. 4)

With the union nut (2) slightly unscrewed, turn the air cap (1) to the desired spray setting position. Then tighten the union nut.

#### **WARNING!**

Danger of injury! Never pull the trigger guard while adjusting the air cap. Adjusting the material Volume (Fig.5)

Set the material volume by turning the regulator on the trigger guard of the spray gun.

- turn to downside – lower material volume

+ turn to upside – higher material volume

#### Spray Technique

- The spray result depends heavily on the smoothness and cleanliness of the surface to be sprayed. Therefore the surface should be carefully prepared and kept free of dust.

- Cover all surfaces not to be sprayed.

- Cover screw threads or similar parts of the target object.

- It is advisable to test the spray gun on cardboard or a similar surface to find the correct setting.

Important: Begin spraying outside of the target area and avoid interruptions inside the target area.

- Correct (Fig. 6a). Be sure to hold the spray gun at an even distance of approx. 30-10 cm to the target object.

- Incorrect (Fig. 6b) Heavy spray fog build-up, uneven surface quality.

- Move the spray gun evenly cross-wise or up – and – down, depending on the spray pattern setting.

- An even movement of the spray gun results in an even surface quality.

- When coating material builds up on the nozzle (A) and air cap (B) (Fig. 7), clean both parts with a solvent or water.

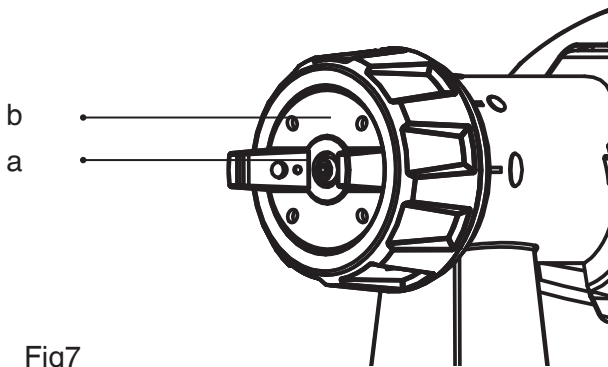

Fig7

Interruption of work till 4 Hours

- Turn the machine off.

-When processing -2component varnishes, clean the device immediately.

Taking out of Operation and cleaning

Proper cleaning is the prerequisite for problem-free operation of the paint application device. No warranty claims are accepted in case of improper or no cleaning.

1) Unplug the power plug. Vent the container in case of longer breaks and after the work has been terminated. This can be done by briefly turning open and then closing the container or by pulling the trigger guard and letting the paint into the original paint container.

2) Divide the spray gun. Press the unlock button (Fig. 8) downwards.

3) Unscrew the container. Empty any remaining coating material back into the material tin.

4) Pre clean the container and suction tube with a brush.

5) Pour solvent or water into the container. Screw the container back on. Use only solvents with a flashpoint over 21C.

6) Assemble the gun again.

7) Insert the power plug, turn on the machine and spray the solvent or water into a container or a cloth.

8) repeat the above procedure until the solvent or water emerging from the nozzle is clear.

9) Turn of the machine and remove the plug.

**⚠ CAUTION!**

Never clean seals, diaphragm and nozzle or air holes of the spray gun with metal objects.

The ventilation hose and diaphragm are only solvent-resistant to a limited extent. Do not immerse in solvent, only wipe.

**⚠ WARNING!**

Never hold the spray gun rear part under water or immerse it into liquids. Clean the housing only with a moistened cloth.

10) clean the outside of the spray gun and container with a cloth soaked in solvent or water.

11) Unscrew the union nut and remove the air cap and nozzle. Clean the air cap and nozzle with a brush and solvent or water.

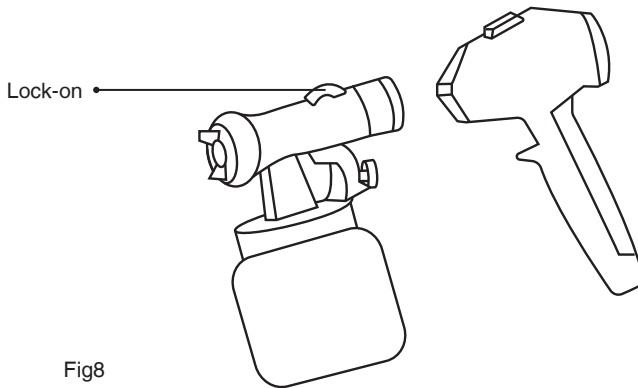

Fig8

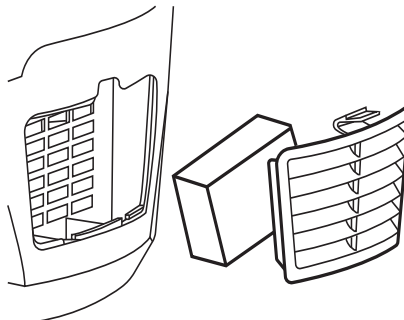

Fig9

## MAINTENANCE

Change the air filter if it is soiled (Fig. 9, item 7).

### **WARNING!**

Never operate the machine without the air filter; dirt could be sucked in and interfere with the function of the machine.

Problem	Cause	Remedy
No coating material emerges from the nozzle	Nozzle clogged Feed tube clogged Material volume setting turned too far to the left (-) Feed tube loose No pressure build-up in container	Clean Clean Turn to the right (+) Insert Tighten container
Coating material drips	Nozzle loose Nozzle worn Nozzle seal worn Coating material assembly at air cap, nozzle or needle	Tighten Change Change Clean
Atomization too coarse	Viscosity of coating material too high material volume too large Material volume adjusting screw turned Too far to the right (+) Nozzle contaminated Air filter heavily soiled Too little pressure build-up in	Thin Turn material volume adjusting Screw to the left (-) Clean Change Tighten container

Spray jet Pulsates	Container Coating material in container running out Air filter heavily soiled	Refill Change
Coating material Causes "paint tears"	Too much coating material applied.	Turn material volume adjusting screw to the left (-)
Paint in the ventilating hose	Diaphragm soiled Diaphragm defective	Clean the diaphragm Replace the diaphragm

### ■ ENVIRONMENTAL PROTECTION

The appliance and accessories should be recycled in an environmentally friendly way. Do not dispose of the appliance with household waste. Support environmental protection by taking the appliance to a local collection point or obtain information from a specialist retailer.





**Ronix**<sup>®</sup>  
Premium Quality

[www.ronixtools.com](http://www.ronixtools.com)