

Ronix[®]

Premium Quality

GASOLINE INVERTER GENERATOR 1200W RH-4791



SPECIFICATIONS

Model		RH-4791
Generator	Type	Inverter Generator
	AC Voltage	220V / 50Hz
	Max. Output	1.2KW
	Rated Output	1.0KW
	Power Factor	1.0
	DC Output	DC12V 4A
Engine	Model	XY144F-1
	Type	Air-cooled,4 cycle,OHV, Gasoline Engine
	Bore×Stroke mm×mm	44×39.5
	Displacement	60 cc
	Max. Output	1.3KW/5500rpm
	Fuel	Regular Automobile Gasoline
	Fuel tank Capacity	3.0liters
	Rated Continuous Operation	4.4 hr
	Lubricating oil	SAE 10W30
	Lubricating oil Capacity	0.27 liter
	Starting System	Recoil Starter
	Ignition system	C.D.I.
	Spark Plug: Type	A5RTC (TORCH)
Dimension	Net dimension L×W×H	448×236×392
	Overall dimension L×W×H	480×255×425
	Net Weight	12Kg
	Gross Weight	13.5kg

PARTS LIST

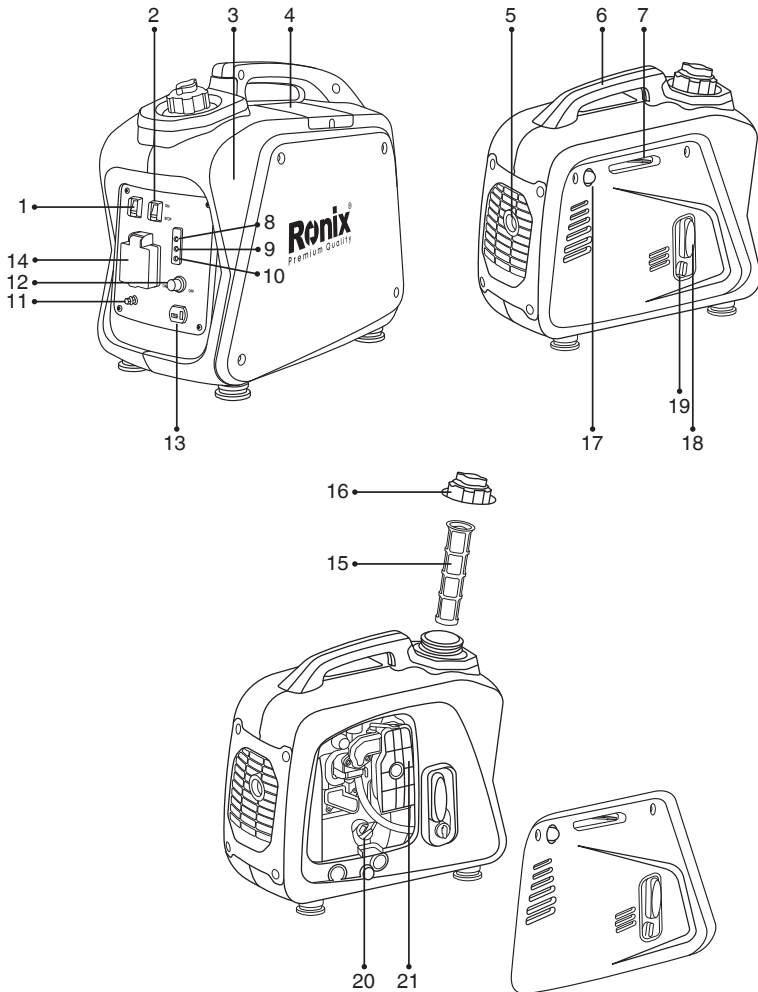

- 1- Economy control switch
- 2- Engine switch
- 3- Fuel tank
- 4- Spark plug

- 5- Muffler
- 6- Carrying handle
- 7- Choke lever
- 8- AC pilot light
- 9- Overload indicator light
- 10- Oil warning light
- 11- Ground (earth) terminal
- 12- DC protector
- 13- DC receptacle
- 14- AC receptacle
- 15- Fuel filter
- 16- Fuel tank cap
- 17- Fuel pump
- 18- Recoil starter
- 19- Fuel cock
- 20- Oil filler cap
- 21- Air filter cover

 **WARNING!**

- PLEASE READ AND UNDERSTAND THIS MANUAL COMPLETELY BEFORE OPERATING THE MACHINE.

WORK AREA SAFETY

■ EXHAUST FUMES ARE POISONOUS

- Never operate the engine in a closed area or it may cause unconsciousness and death within a short time. Operate the engine in a well ventilated area.

■ FUEL IS HIGHLY FLAMMABLE AND POISONOUS

- Always turn off the engine when refueling
- Never refuel while smoking or in the vicinity of an open flame.
- Take care not to spill any fuel on the engine or muffler when refueling.

- If you swallow any fuel, inhale fuel vapor, or allow any to get in your eyes, see your doctor immediately. If any fuel spills on your skin or clothing, immediately wash with soap and water and change your clothes.
- When operating or transporting the machine, be sure it is kept upright. If it tilts, fuel may leak from the carburetor or fuel tank.

■ ENGINE AND MUFFLER MAY BE HOT

- Place the machine in a place where pedestrians or children are not likely to touch the machine.
- Avoid placing any flammable materials near the exhaust outlet during operation.
- Keep the machine at least 1 m (3 ft) from buildings or other equipment, or the engine may overheat.
- Avoid operating the engine with a dust cover.
- Be sure to carry the generator only by its carrying handle.
- Put the machine on the flat ground, for the machine eliminating heat freely.

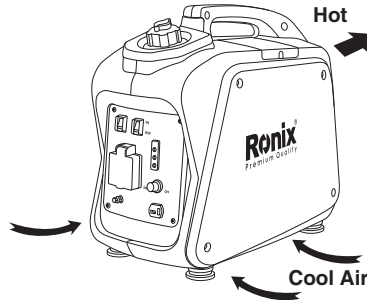

■ ELECTRIC SHOCK PREVENTION

- Never operate the engine in rain or snow.
- Never touch the machine with wet hands or electrical shock will occur.
- Be sure to ground (earth) the generator.

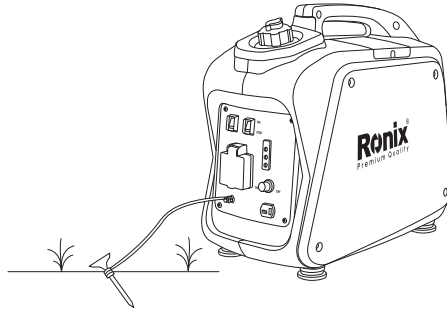

⚠ NOTE:

Use ground (earth) lead of sufficient current capacity.

- Diameter: 0.12mm (0.005 in)/ampere
- EX: 10 Ampere -1.2mm (0.055 in)

■ CONNECTION NOTES

- Avoid connecting the generator to commercial power outlet.
- Avoid connecting the generator in parallel with any other generator.

CONTROL FUNCTION

■ OIL WARNING SYSTEM

- When the oil level falls below the lower level, the engine stops automatically. Unless you refill with oil, the engine will not start again.

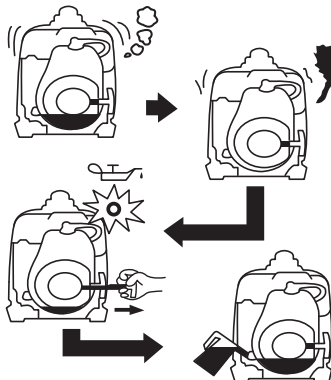

■ENGINE SWITCH

- The engine switch controls the ignition system.

ON (run)

- Ignition circuit is switched on. The engine can be started.

OFF (stop)

- Ignition circuit is switched off. The engine will not run.

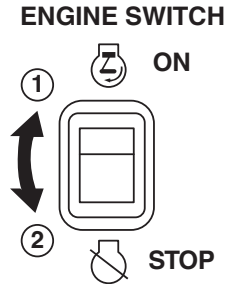

■ECONOMY CONTROL SWITCH

When the economy control switch is turned “ON”, the economy control unit control the engine speed according to the connected load. The results are better fuel connection and less noise.

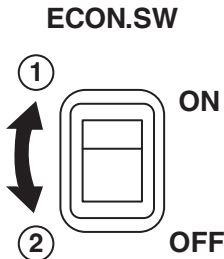

■DC CIRCUIT PROTECTOR

The DC circuit protector turns off automatically when the load exceeds the generator rated output.

▲ CAUTION:

- Reduce the load to within specified generator rated output if the DC

circuit protector turn off.

DC PROTECTOR



■ FUEL TANK CAP AIR VENT KNOB

The fuel tank cap is provided with an air vent knob to stop fuel flow. The air vent knob must be turned once clockwise from the closed position. This will allow fuel to flow to the carburetor and the engine to run. When the engine is not in use, tighten the air vent knob counterclockwise until it is finger-tight to stop fuel flow.

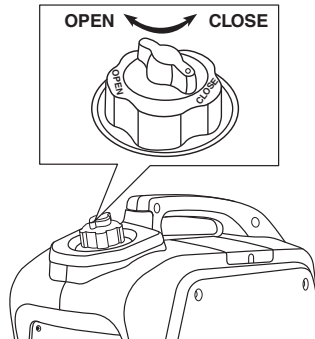

■ FUEL COCK

The fuel cock is used to supply fuel from the tank to the carburetor.

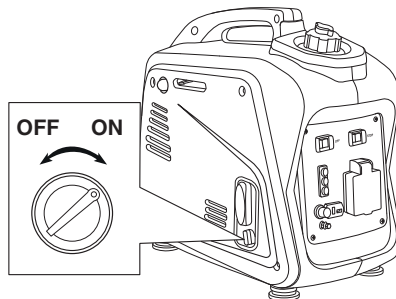

PRE-OPERATION CHECK

⚠ NOTE:

- Pre-operation checks should be made each time the generator is used.

■ CHECK ENGINE FUEL

- Make sure there is sufficient fuel in the tank.
- If fuel is low, refill with unleaded automotive gasoline.
- Be sure to use the fuel filter screen on the fuel filter neck.
- Recommended fuel: Unleaded gasoline.
- Fuel tank capacity: (see page 3)

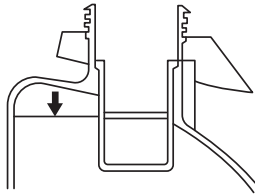

⚠ WARNING!

- Do not refill tank while engine is running or hot.
- Close fuel cock before refueling with fuel.
- Be careful not to admit dust, dirt, water or other foreign objects into fuel.
- Do not fill above the top of the fuel filter or it may overflow when the fuel heats up later and expands.
- Wipe off spilt fuel thoroughly before starting engine.
- Keep open flames away.

■ CHECK ENGINE OIL

Make sure the engine oil is at the upper level of the oil filler hole. Add oil as necessary.

- Remove oil filler cap and check the engine oil level.
- If oil level is below the lower level line, refill with suitable oil to upper level line. Do not screw in the oil filler cap when checking oil level.
- Change oil if contaminated.
- Oil capacity: (see page 3)
- Recommended engine oil:
API Service SJ

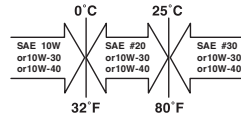
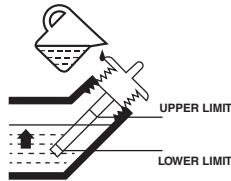
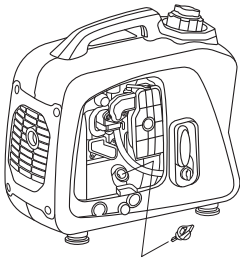

■ GROUND (EARTH)

- Make sure to ground (earth) the generator.

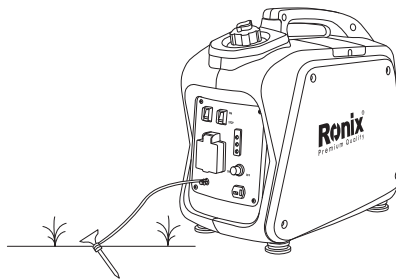

OPERATION

▲ NOTE:

- The generator has been shipped without engine oil. Fill with oil or it will not start.

- Do not tilt the generator when adding engine oil. This could result in overfilling and damage to the engine

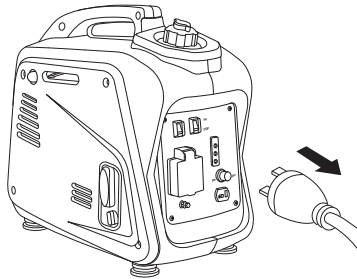

STARTING THE ENGINE

⚠ NOTE:

- Before starting the engine, do not connect the electric apparatus.
- Open the fuel tank air vent to the OPEN position.

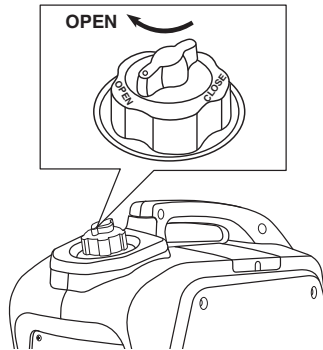

- Turn the fuel cock lever to the ON position.

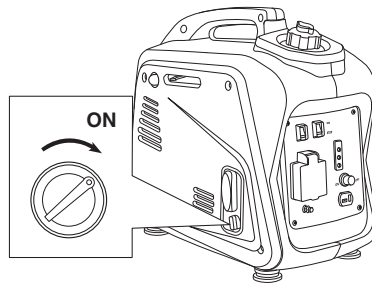

- Turn the engine switch to the ON position.

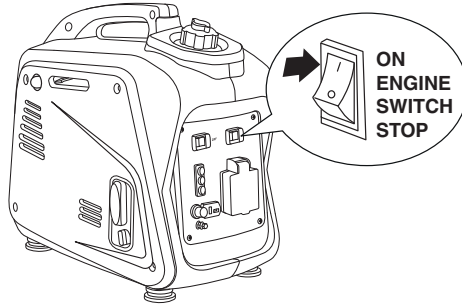

- When first time to use the generator sets, pressing the primer bulb 6 times after refuel gasoline

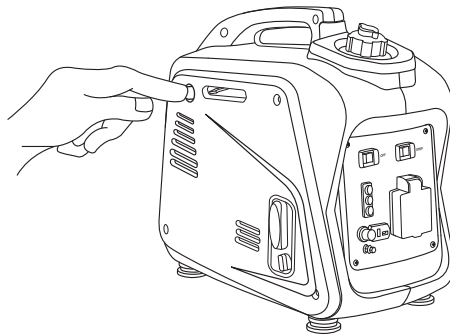

- Turn the choke lever to the |  CHOKE position. Not necessary if the engine is warm.

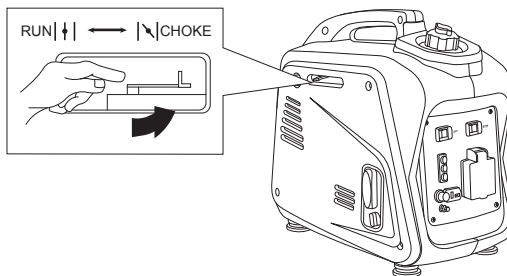

- Pull the starter handle slowly until resistance is felt. This is the Compression point. Return the handle to its original position and pull swiftly. Do not fully pull out the rope. After starting, allow the starter handle to return to its original position while still holding the handle. Grasp the carrying handle firmly to prevent the generator from falling over when pulling the recoil starter.
- Warm up the engine.
- Turn the choke lever back to the | ♯ | RUN position.

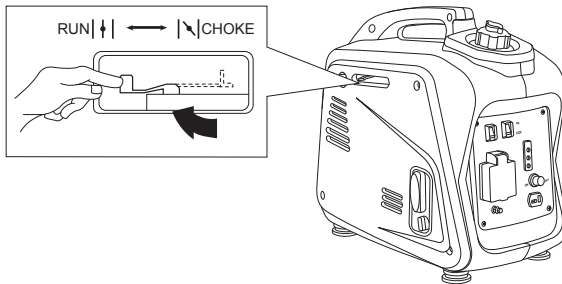

- Warm up the engine without a load for a few minutes.

USING ELECTRIC POWER

■ AC APPLICATION

- Check the AC pilot lamp for proper voltage.
- Turn off the switch(es) of the electrical appliance(s) before connecting to the generator.
- Insert the plug(s) of the electrical appliance(s) into the receptacle.

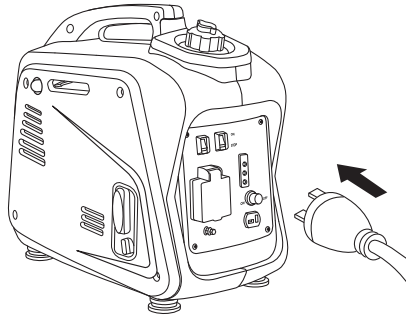

⚠ CAUTION:

- Be sure the electric apparatus is turned off before plugging in.
- Be sure the total load is within generator rated output.
- Be sure the socket load current is within socket rated current.

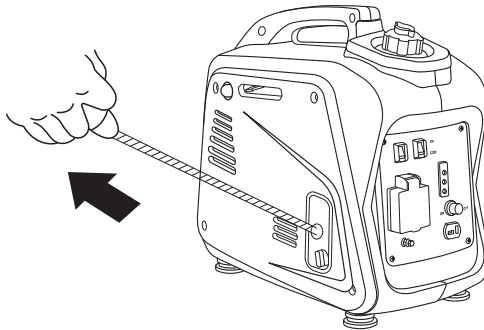

- The economy control switch must be turned to OFF when using electric devices that require a large starting current, such as a compressor or a submersible pump.

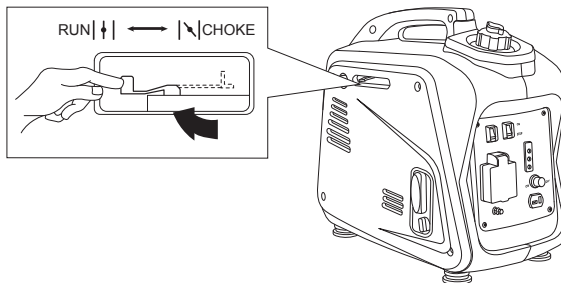

■ OVERLOAD INDICATOR LIGHT

The overload indicator light comes on when an overload of a connected electrical device is detected, the inverter unit overheats, or the AC output voltage rises. The electronic breaker will then activate, stopping power to the generation in order to protect the generator and any connected electric devices. The output pilot light (green) will flicker and the overload indicator light (red) will turn on, then the engine will stop running. If so please follow the following steps:

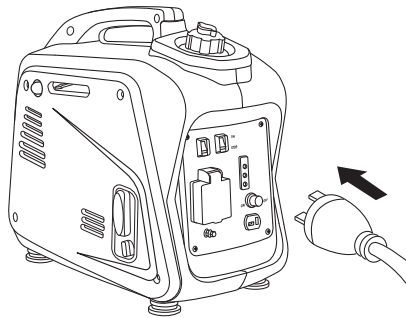

- Turn off any connected electric devices and stop the engine

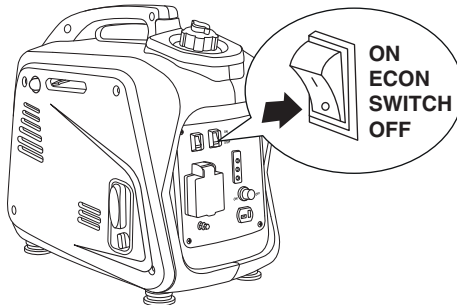

- Reduce the total wattage of connected electric devices within the application range.
- Check for blockages in the cooling air inlet and around the control unit. If any blockages are found, remove.
- After checking, restart the engine.

⚠ CAUTION:

- The generator AC output automatically resets when the engine is stopped and then restarted.
- The overload indicator light may come on for a few seconds at first when using electric devices that require a large starting current, such as a compressor or a submersible pump. However, this is not a malfunction.

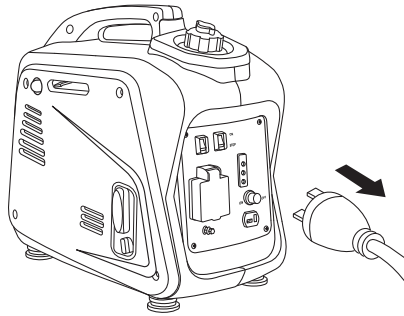

■ DC APPLICATION (OPTION)

This usage is applicable to 12V battery charging only.

- Charging instruction for battery
- Disconnect the leads for the battery.
- Make the battery fluid filler cap loose fully.
- Fill distilled water to the upper limit, if the battery fluid is low level.
- Measure the specific gravity for the battery fluid by using the hydrometer, and calculate the charging time in according with the table shown on right side.
- The specific gravity for the fully charged battery shall be within 1.26 to 1.28. It is recommended to confirm every hour.
- Connect between the DC output socket and the battery terminals using the charging leads. The leads shall be connected making sure of the (+) and (-) polarity.
- The DC circuit protector is to be set to ON after confirming the connection, if the protector is in OFF position.

Aim for Specific Gravity and Charging Time

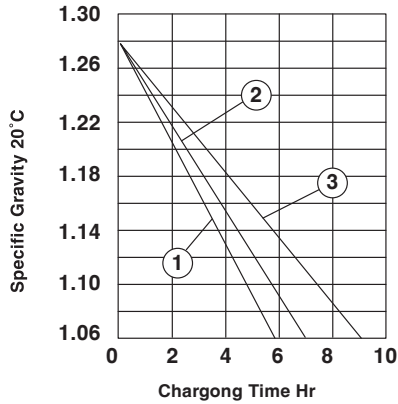

Battery Capacity

1. 30AH 20HR
2. 35AH 20HR
3. 47AH 20HR

⚠ CAUTION:

- Be sure the economy control switch is turned OFF while charging the battery.

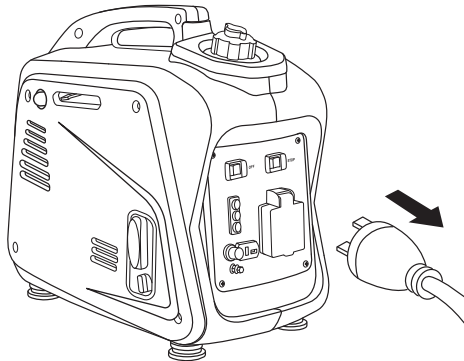

■ STOPPING THE ENGINE

- Turn off the power switch of the electric apparatus or disconnect any electric devices.
- Turn the engine switch to STOP position.

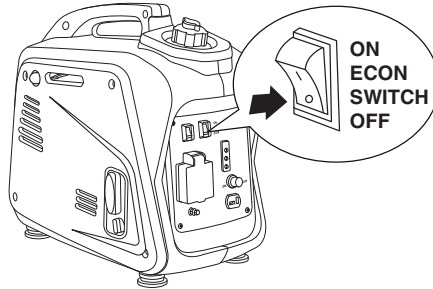

- Turn the fuel cock lever to OFF.

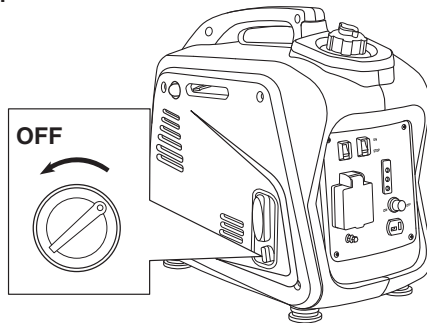

- Turn the fuel tank cap air vent knob counterclockwise to the CLOSED position.

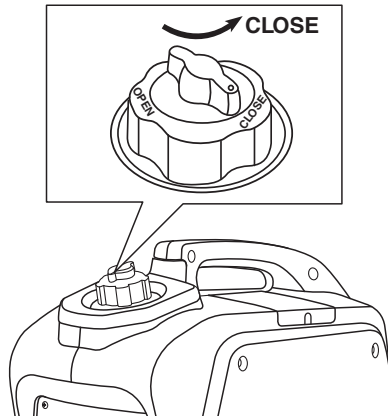

PERIODIC MAINTENANCE

■ MAINTENANCE CHART

- Regular maintenance is most important for the best performance and safe operation.

Item	Remarks	Pre-operation check (daily)	Initial 1 months or 20 Hr	Every 3 months or 50Hr	Every 6 months or 100Hr	Every 12 months or 300Hr
Spark Plug	Check condition adjust gap and clean. Replace if necessary.			•		
Engine Oil	Check oil level	•				
	Replace		•		•	
Oil filter	Clean oil filter				•	
Air Filter	Clean. Replace if necessary.			•		
Fuel Filter	Clean fuel cock filter. Replace if necessary				•	
Choke	Check choke operation	•				
Valve Clearance	Check and adjust when engine is cold.					•
Fuel Line	Check fuel hose for crack or damage. Replace if necessary.	•				

Exhaust System	Check for leakage. Retighten or replace gasket if necessary	•				
	Check muffler screen. Clean / replace if necessary.					•
Carburetor	Check choke operation	•				
Cooling system	Check fan damage.					•
Starting system	Check recoil starter operation.	•				
Idle speed	Check and adjust engine idle speed					•
Fittings/ Fasteners	Check all fittings and fasteners correct if necessary.				•	
Crankcase breather	Check breather hose for cracks or damage. Replace if necessary					•
Generator	Check the pilot light comes on	•				

■ ENGINE OIL REPLACEMENT

- Place the machine on a level surface and warm up the engine for several minutes. Then stop the engine and turn the fuel cock knob to OFF. Turn the fuel tank cap air vent knob clockwise.
- Loosen the screw and remove the cover.

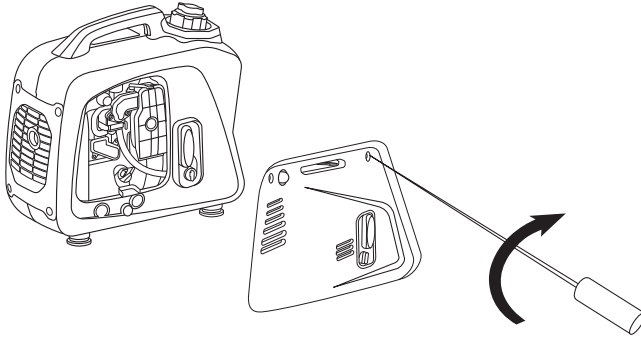

- Remove the oil filler cap
- Place an oil pan under the engine. Tilt the generator to drain the oil completely

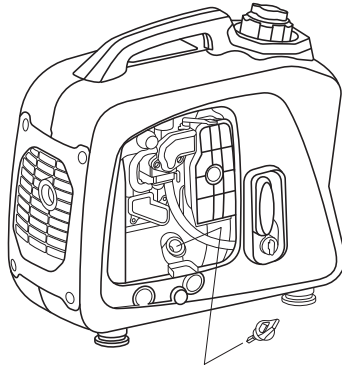

- Replace the generator on a level surface.

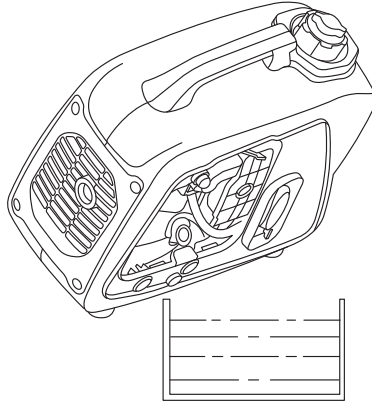

- Add engine oil to the upper level.
- Install the oil filler cap
- Install the cover and tighten the screw
- Recommended engine oil: (see page 3)
- API Service “ SJ”

⚠ CAUTION:

- Be sure no foreign material enters the crankcase.
- Do not tilt the generator when adding engine oil. This could result in overfilling and damage to the engine
- Clean the oil filter every other 100hr.

AIR FILTER

Maintaining an air cleaner in proper condition is very important. Dirt induced through improperly installed, improperly serviced, or inadequate elements damages and wears out engines. Keep the element always clean.

- Remove the cover.
- Remove the air filter cover and element.
- Wash the element in solvent and dry.
- Oil the element and squeeze out excess oil. The element should be

wet but not dripping.

- Insert the element into the air filter.
- Install the cover

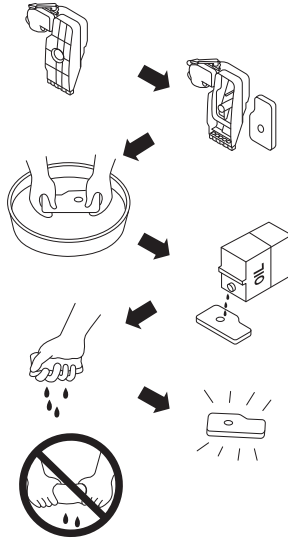

⚠ CAUTION:

The engine should never run without the element; excessive piston and/or cylinder wear may result.

■ CLEANING AND ADJUSTING SPARK PLUG

- Remove the cover.
- Check for discoloration and remove the carbon.
- Check the spark plug type and gap.
- Install the spark plug.
- Install the cover

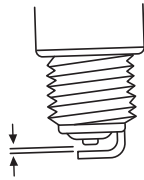
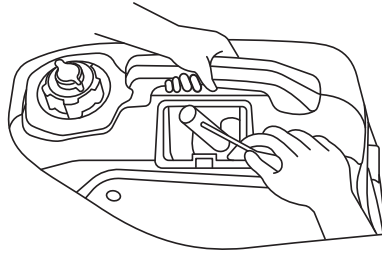

- Standard electrode color: Tan Color
- Standard Spark Plug: see page 3
- Spark Plug Gap: 0.6-0.7 mm (0.024-0.028 in)

■ FUEL TANK FILTER

- Remove the fuel tank cap and filter.
- Clean the filter with solvent. If damaged, replace.
- Wipe the filter and insert it.

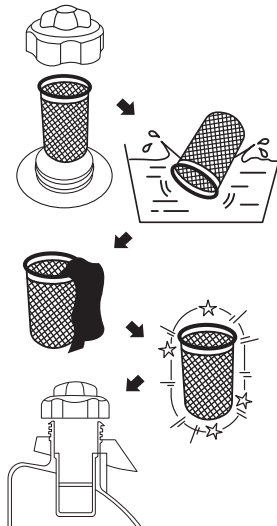

⚠ WARNING!

- Be sure the tank cap is tightened securely.

■ MUFFLER SCREEN

⚠ WARNING!

- The engine and muffler will be very hot after the engine has been run.
- Avoid touching the engine and muffler while they are still hot with any part of your body or clothing during inspection or repair.

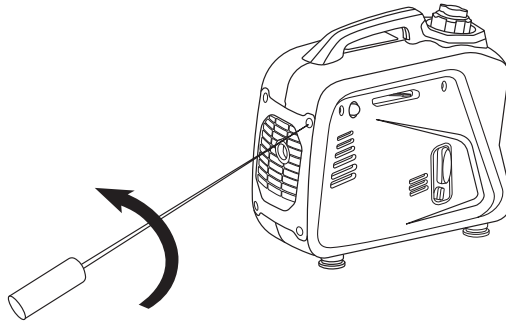

- Remove the cover.
- Remove the muffler screen.
- Use the flathead screw driver to pry the spark arrester out from the muffler

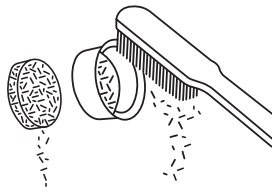
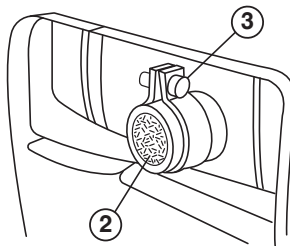

- Remove the carbon deposits on the muffler screen and spark arrester using a wire brush.
- Install the muffler screen.
- Install the cover

TROUBLE SHOOTING

ENGINE WON'T START

■ FUEL SYSTEMS

- No fuel supplied to combustion chamber.
- No fuel in tank → Supply fuel.
- Fuel in tank → Fuel tank cap air vent knob to OPEN, fuel cock knob to ON.
- Clogged fuel line → Clean fuel line.
- Clogged carburetor → Clean carburetor.

■ ENGINE OIL SYSTEM

- Insufficient
- Oil level is low → Add engine oil.

■ ELECTRICAL SYSTEMS

- Poor spark
- Spark plug dirty with carbon or wet → Remove carbon or wipe spark plug dry.
- Faulty ignition system → Consult dealer.

■ COMPRESSION INSUFFICIENT

- Worn out piston and cylinder → Consult dealer.

GENERATOR WON'T PRODUCE POWER

Safety device (AC) to "OFF" → Stop the engine, then restart.

Safety device (DC) to "OFF" → Press to reset the DC protector

STORAGE

Long term storage of your machine will require some preventive procedures to guard against deterioration.

DRAIN THE FUEL

- Remove the fuel tank cap, drain the fuel from the fuel tank
- Remove the cover, drain fuel from the carburetor by loosening the drain screw.

ENGINE

- Remove the spark plug, pour in about one tablespoon of SAE 10W30 or 15W40 motor oil into the spark plug hole and reinstall the spark plug.
- Use the recoil starter to turn the engine over several times (with ignition off).
- pull the recoil starter until you feel compression.
- Stop pulling.
- Clean exterior of the generator and apply a rust inhibitor.
- Store the generator in a dry, well-ventilated place, with the cover place over it.
- The generator must remain in a vertical position.

Ronix[®]
Premium Quality