

Ronix[®]

Premium Quality

GASOLINE GENERATOR 7500W

RH-4784

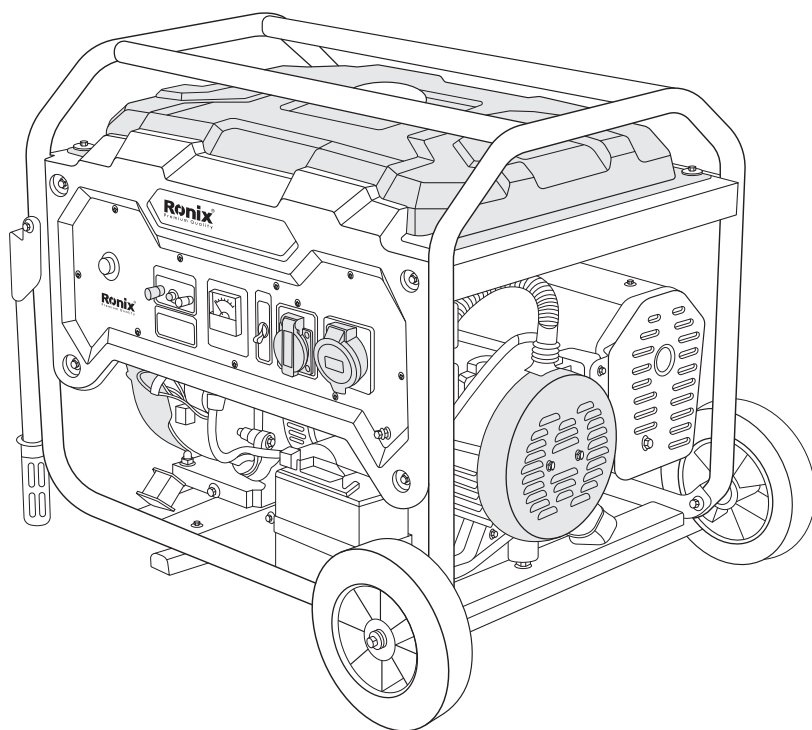

SPECIFICATIONS

| | | |
|-----------|-------------------------------|--|
| Model | | RH-4784 |
| Generator | Type | Gasoline Generator |
| | AC Voltage | 220V |
| | Rated Amperage | 32A |
| | Frequency | 50Hz |
| | Max.Output | 7.5KW |
| | Rated Output | 7KW |
| | Power Factor | 1 |
| | DC Output | DC12V,8.3A |
| Engine | Model | FC192F |
| | Type | Single Cylinder 4-stroke, forced air cooled |
| | Bore×Stroke | 92mm×69mm |
| | Displacement | 460cc |
| | Max.Output | 10KW / 3600RPM |
| | Fuel | Gasoline |
| | Fuel tank Capacity | 25 Lit |
| | Rated Continuous Operation | 6.5hr |
| | Lubricating Oil | SAE 10W-30 |
| | Lubricating Oil Capacity | 1.1 liter |
| | Starting System | Recoil & E-start |
| | Lgnition System | T.C.I |
| | Spark Plug Type | F7TC/F7RTC |
| | Maximum Fuel Consumption Rate | 3.85Lit/hr |

| | | |
|-------------|--|-------------------|
| Dimension | Net Dimension LxWxH | 686mmx516mmx560mm |
| | Overall Dimension LxWxH | 740mmx575mmx625mm |
| | Net Weight | 86Kg |
| | Gross Weight | 88Kg |
| Supplied in | Carton | |
| Include | 2 Plug, 1 Spark Plug Sleeve, 1 Rod, 12V DC Output Clip, 2 Key, 1 Set Wheels and Handles | |

PARTS LIST

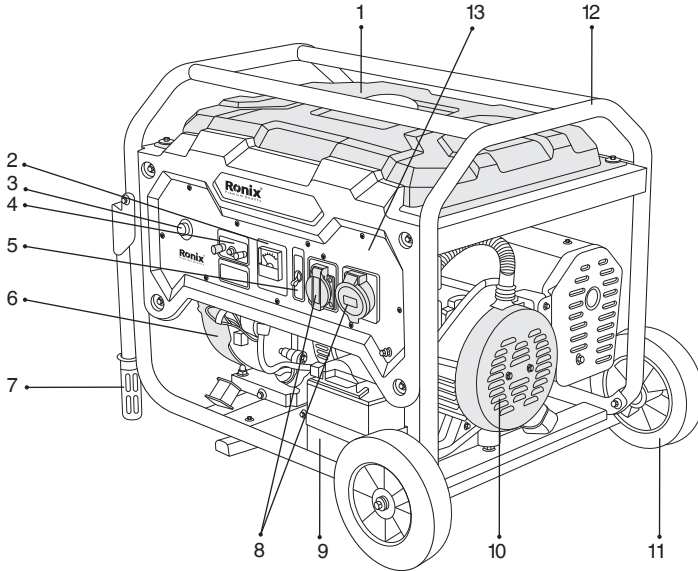

- 1- Fuel tank
- 2- Voltmeter
- 3- Engine switch
- 4- DC socket
- 5- Circuit breaker
- 6- Internal combustion engine
- 7- handle

- 8- AC socket
- 9- Battery
- 10- Generator
- 11- Wheel
- 12- Frame
- 13- Control panel

SAFETY INFORMATION

Generators are designed to give safe and dependable service if operated according to instructions. Read and understand this owner's manual before operating your generator. You can help prevent accidents by being familiar with your generator's controls, and by observing safe operating procedures.

OPERATOR RESPONSIBILITY

- Know how to stop the generator quickly in case of emergency.
- Understand the use of all generator controls, output receptacles, and connections.
- Be sure that anyone who operates the generator receives proper instruction. Do not let children operate the generator without parental supervision.

CARBON MONOXIDE HAZARDS

- Exhaust contains poisonous carbon monoxide, a colorless and odorless gas. Breathing exhaust can cause loss of consciousness and may lead to death.
- If you run the generator in an areas that is confined, or even partially enclosed, the air you breathe could contain a dangerous amount of exhaust gas. To keep exhaust gas from accumulating, provide adequate ventilation.

ELECTRIC SHOCK HAZARDS

- The Generator produces enough electric power to cause a serious shock or electrocution if misused.
- Using a generator or electrical appliance in wet conditions, such as rain or snow, or near a pool or sprinkler system, or when your hands are wet, could result in electrocution. Keep the generator dry.
- If the generator is stored outdoors, unprotected from the weather, check all electrical components on the control panel, before each use. Moisture or ice can cause a malfunction or short circuit in electrical components which could result in electrocution.
- Do not connect to a building electrical system unless an isolation switch has been installed by a qualified electrician.
- The muffler becomes very hot during operation and remains hot for a while after stopping the engine. Be careful not to touch the muffler while it is hot. Let the engine cool before storing the generator indoors.
- Gasoline is extremely flammable and is explosive under certain conditions. Do not smoke or allow flames or sparks where the generator is refueled or where gasoline is stored. Refuel in a well-ventilated area with the engine stopped.
- Fuel vapors are extremely flammable and may ignite after the engine has started. Make sure that any spilled fuel has been wiped up before starting the generator.

OPERATING INSTRUCTION

■ STAR AND STOP:

Engine Switch is used to start and stop the engine.

Switch position:

OFF: To Stop the engine.

ON: To run the engine.

START: To start the engine (only for electric start)



Electric Start

RECOIL STARTER

To start the engine, pull the starter grip lightly resistance is felt, then pull briskly.

NOTICE:

Do not allow the starter grip to snap back against the engine. Return it gently to prevent damage to the starter.

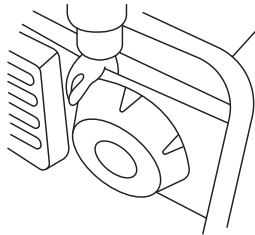

FUEL VALVE LEVER

The fuel valve is located between the fuel tank and carburetor. When the valve lever is in the ON position, fuel is allowed to flow from the fuel tank to the carburetor. Be sure to return the fuel valve lever to the OFF position after stopping the engine.

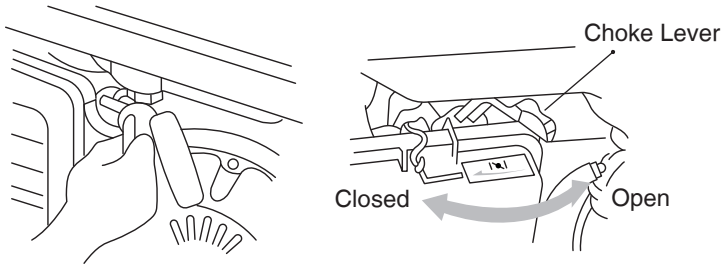

CHOKE ROD

The choke is used to provide an enriched fuel mixture when starting a cold engine. It can be opened and closed by operating the choke lever manually. Pull the rod out toward **CLOSED** to enrich the mixture for cold starting.

GROUND TERMINAL

The generator ground terminal is connected to the frame of the generator, the metal non-current-carrying parts of the generator, and the ground terminals of each receptacle.

Before using the ground terminal, consult a qualified electrician, electrical inspector or local agency having jurisdiction for local codes or ordinances that apply to the intended use of the generator.

AC CIRCUIT BREAKER

The AC circuit breaker will automatically switch **OFF** if there is a short circuit or a significant overload of the generator at the receptacle.

If the AC circuit breaker is switched **OFF** automatically, check that the appliance is working properly and does not exceed the rated load capacity of the AC circuit before switching the circuit breaker **ON** again.

The circuit breaker may be used to switch the generator AC power **ON** or **OFF**.



Electric Start

CONNECTIONS TO BUILDING ELECTRICAL SYSTEM

Connections for standby power to a building electrical system must be made by a qualified electrician. The connection must isolate the generator power from utility power, and must comply with all applicable laws and electrical codes. A transfer switch, which isolates generator power from utility power, is available through authorized generator dealer.

⚠ WARNING!

Improper connections to a building electrical system can allow electrical current from the generator to back feed into the utility lines. Such back feed may electrocute utility company workers or others who contact the lines during a power outage, and the generator may explode, burn, or cause fires when utility power is restored. Consult the utility company or a qualified electrician.

AC APPLICATIONS

Before connecting an appliance or power cord to the generator:

- Make sure that it is in good working order. Faulty appliances or power cords can create a potential for electrical shock.
- If an appliance begins to operate abnormally, becomes sluggish or stops suddenly, turn it off immediately. Disconnect the appliance, and determine whether the problem is the appliance, or if the rated load capacity of the generator has been exceeded.
- Make sure that the electrical rating of the tool or appliance does not exceed

that of the generator. Never exceed the maximum power rating of the generator. Power levels between rated and maximum may be used for no more than 30 minutes.

⚠ NOTICE:

Substantial overloading will open the circuit breaker. Exceeding the time limit for maximum power operation or slightly overloading the generator may not switch the circuit breaker OFF, but will shorten the service life of the generator.

AC OPERATION

- 1- Start the engine
- 2- Switch ON the AC circuit breaker.
- 3- Plug in the appliance.

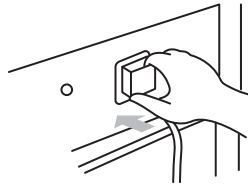

⚠ NOTICE:

-Most motorized appliances require more than rated wattage for startup. Do not exceed the current limit specified for any one receptacle. If an overloaded circuit causes the AC circuit breaker to switch OFF, reduce the electrical load on the circuit, wait a few minutes and then reset the circuit breaker.

PRE-OPERATION CHECK

■ ENGINE OIL

⚠ NOTICE:

Engine oil is a major factor affecting engine performance and service

life. Non-detergent and 2-stroke engine oils will damage the engine and are not recommended.

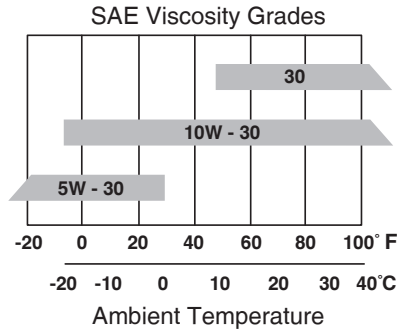

Check the oil level **BEFORE EACH USE** with the generator on a level surface and the engine stopped.

Use 4-stroke motor oil that meets or exceeds the requirements for API service classification SJ. Always check the API **SERVICE** label on the oil container to be sure it includes the letters SJ.

SAE 10W-30 is recommended for general, all-temperature use.

Other viscosities shown in the chart may be used when the average temperature in your area is within the indicated range.

PRE-OPERATION CHECK

- 1- Remove the oil filler cap and wipe the dipstick clean.
- 2- Check the oil level by inserting the dipstick into the filler neck without screwing it in.
- 3- If the level is low, fill to the top of the oil filler neck with the recommended oil.

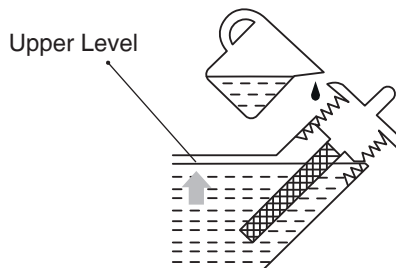

FUEL

Check the fuel gauge, and refill the tank if the fuel level is low. Refuel carefully to avoid spilling fuel. Do not fill above the shoulder of the fuel strainer.

⚠ WARNING!

Gasoline is highly flammable and explosive, and you can be burned or seriously injured when refueling.

- Stop engine and keep heat, sparks, and flame away.
- Refuel only outdoors.
- Wipe up spills immediately.

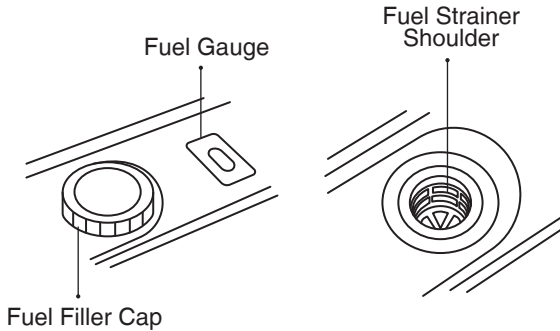

⚠ NOTICE:

Fuel can damage paint and plastic. Be careful not to spill fuel when filling your fuel tank. Damage caused by spilling fuel is not covered under warranty.

Use unleaded gasoline with a pump octane of 86 or higher.

This engine is certified to operate on unleaded gasoline.

Unleaded gasoline produces fewer engine and spark plug deposits and extends exhaust system life,

Never use stale or contaminated gasoline or oil/gasoline mixture.

Avoid getting dirt or water in the fuel tank.

Occasionally you may hear a light “Spark knock” or “pinging” (metallic rapping noise) while operating under heavy loads. This is no cause for concern.

If spark knock or pinging occurs at a steady engine speed, under normal load, change brands of gasoline. If spark knock or pinging persists, see an authorized to manual.

⚠ NOTICE:

Running the engine with persistent spark knock or pinging is misuse, and the Distributor's Limited Warranty does not cover parts damaged by misuse.

STARTING THE ENGINE/STOPPING THE ENGINE

■ STARTING THE ENGINE

- 1- Make sure that the AC circuit breaker is in the OFF position. The generator may be hard to start if a load is connected.
- 2- Turn the fuel valve lever to the ON position.
- 3- Turn the choke rod to the CLOSED position.
- 4- Move the engine switch to the ON position.
- 5- Pull the starter grip lightly until resistance is felt, then pull briskly.
- 6- As the engine warms up, slowly push the choke rod to the OPEN position.

■ STOPPING THE ENGINE

.In an emergency:

To stop the generator in an emergency, turn the engine switch to the OFF position.

■ AFTER USE:









- 1- Turn the AC circuit breaker to the OFF position.
- 2- Turn the engine switch to the OFF position.
- 3- Turn the fuel valve lever to the OFF position.

SERVICE

Always do as the following so as to keep the generator in a sound condition.

⚠ WARNING!

1- If the generator is to supply tow or above loads to the earth or the Recreational with power supply, be sure to connect them one with higher start current fist.

| Description | Wattage | | Typified | Example | | |
|-------------------------------------|---------|--------|--|---|---------------|-----------|
| | Start | Rating | | Electric device | Start | Rating |
| Incandescent lamp Heating device | x1 | x1 | Incandescent lamp  TV  |  100W Incandescent lamp | 100VA (W) | 100VA (W) |
| Fluorescent lamp | x2 | x1.5 | Fluorescent lamp  |  40W Fluorescent lamp | 80VA (W) | 60VA (W) |
| Drive device | x3-5 | x2 | Refrigerator  Electric fan  |  150W Refrigerator | 450-750VA (W) | 300VA (W) |

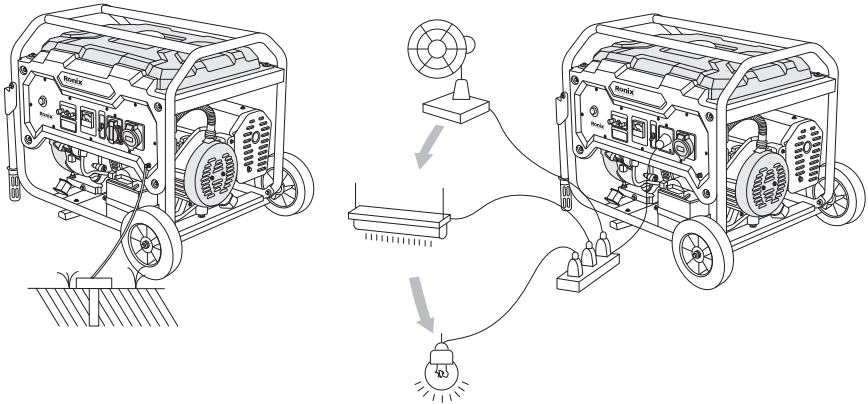

Don't move the earth wire during normal maintenance or repair.

2- The following table gives reference information for connecting the

electric appliances to the generator.
Connecting methods are illustrated as follow.

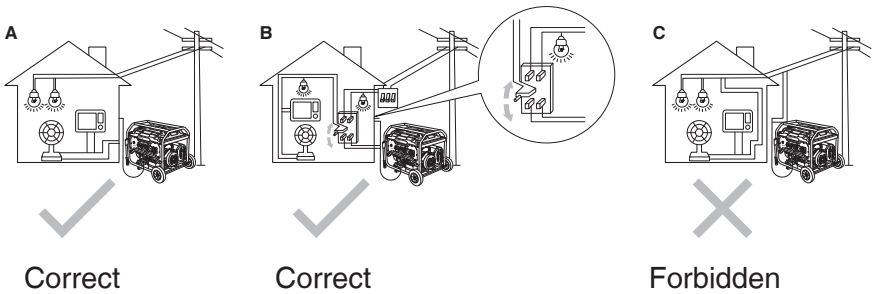

When connect the generator home power supply, be sure that a skilled electrician dose this job. Improper connecting between the generator and loads may cause damage to the generator, even a fire.

MAINTENANCE

■ THE IMPORTANCE OF MAINTENANCE

Good maintenance is essential for safe, economical, and trouble-free operation. It will also help reduce air pollution.

⚠ WARNING!

Improper maintenance, or failure to correct a problem before operation, can cause malfunction in with you can be seriously hurt or killed.

The maintenance schedule applies to normal operating conditions. If you operate your generator under sever conditions, such as sustained high-load or high-temperature operation, or use it in unusually wet or dusty conditions, consult your servicing needs and use.

-Make sure the engine is off before you begin any maintenance or repairs. This will eliminate several potential hazards:

CARBON MONOXIDE POISONING FROM ENGINE EXHAUST.

Be sure there is adequate ventilation whenever you operate the engine.

BURNS FROM HOT PARTS.

Let the engine and exhaust system cool before touching.

INJURY FROM MOVING PARTS.

- Do not run the engine unless instructed to do so.
- Read the instructions before you begin, and make sure you have the tools and skills required.

MAINTENANCE SCHEDULE

| REGULAR SERVICE PERIOD (3) | | Before each use | Fist month or 20 Hrs. | Every 3 months or 50 Hrs. | Every 6 months or 100 Hrs. | Every year or 300 Hrs. |
|-----------------------------------|--------------|-----------------|-----------------------|---------------------------|----------------------------|------------------------|
| ITEM Performed at every indicated | | | | | | |
| Engine oil | Check level | • | | | | |
| | Change | | • | | • | |
| Air filter | Change | • | | | | |
| | Clean | | | • ¹ | | |
| | Replace | | | | | •* |
| Spark plug | Check-adjust | | | | • | |
| | Replace | | | | | • |
| Spark arrester | Clean | | | | • | |

| | | | | | | |
|-----------------------------|--------------|--|--|--|--|----|
| Idle speed | Check-adjust | | | | | •2 |
| Valve clearance | Check-adjust | | | | | •2 |
| Combustion chamber | Clean | After every 500Hrs. (2) | | | | |
| Fuel tank and filterchamber | Clean | | | | | •2 |
| Fuel tube | Check | Every 2 years (Replace if necessary) (2) | | | | |

- 1- Service more frequently when used in dusty areas.
- 2- These items should be serviced by an authorized generator dealer, unless the owner has the proper tools and is mechanically proficient. See the Shop Manual.
- 3- For commercial use, long hours of operation to determine proper maintenance intervals.

ENGINE OIL CHANGE

Drain the oil while the engine is warm to assure rapid and complete draining.

- 1- Remove the drain plug and sealing washer, remove the oil filler cap, and drain the oil.
- 2- Reinstall the drain plug and sealing washer. Tighten the plug securely.
- 3- Refill with the recommended oil and check the oil lever.

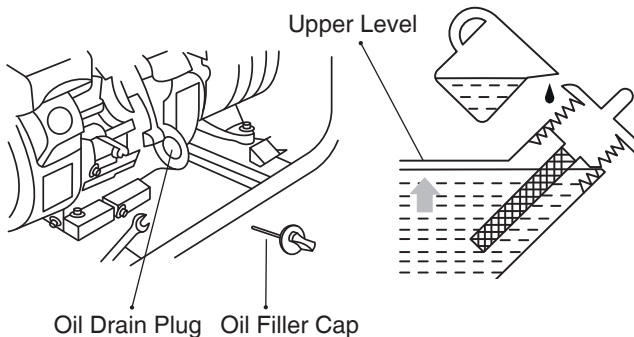

Wash your hands with soap and water after handling used oil. Please dispose of used motor oil in a manner that is compatible with the environment. We suggest you take it in a sealed container to your local service station or recycling center for reclamation. Do not throw it in the trash, pour it on the ground, or down a drain.

AIR CLEANER SERVICE

A dirty air cleaner will restrict air flow to the carburetor. To prevent carburetor malfunction, service the air cleaner regularly. Service more frequently when operation the generator in extremely dusty areas.



NOTICE:

Never run the generator without the air filter. Rapid engine wear will result.

- 1- Unsnap the air cleaner cover clips, remove the air cleaner cover, and remove the element.
- 2- Wash the air cleaner element in a solution of household detergent and warm water, then rinse thoroughly, or wash in nonflammable or high flashpoint solvent. Allow the air cleaner element to dry thoroughly.
- 3- Soak the air cleaner element in clean engine oil and squeeze out the excess oil. The engine will smoke during initial startup if too much oil is left in the air cleaner element.
- 4- Reinstall the air cleaner element and the cover.

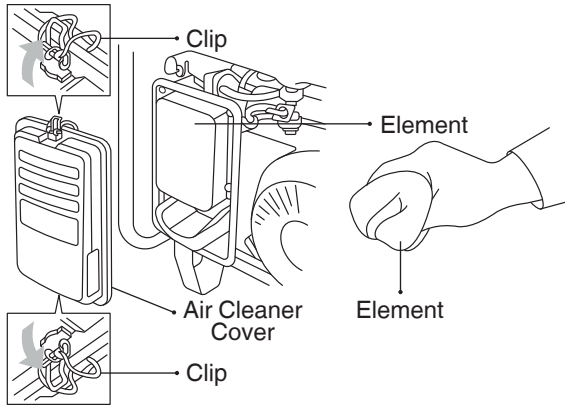

FUEL SEDIMENT CUP CLEANING

The sediment cup prevents dirt or water which may be in the fuel tank from entering the carburetor. If the engine has not been run for a long time, the sediment cup should be cleaned.

- 1- Turn the fuel valve lever to the OFF position. Remove the sediment cup, O-ring, and filter.
- 2- Clean the sediment cup, O-ring, and filter in nonflammable or high flash point solvent.
- 3- Reinstall the filter, O-ring, and sediment cup.
- 4- Turn the fuel valve lever ON and check for leaks.

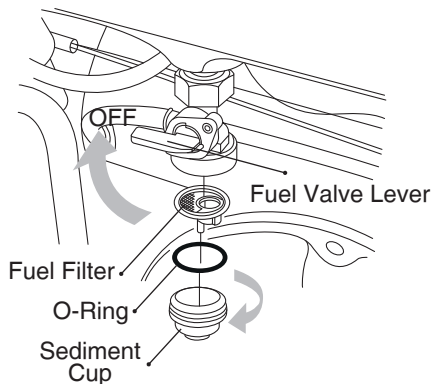

SPARK PLUG SERVICE

In order to service the spark plug, you will need a spark plug wrench (commercially available).

RECOMMENDED SPARK PLUGS: F7TC

To ensure proper engine operation, the spark plug must be properly gapped and free of deposits.

If the engine has been running, the muffler will be very hot. Be careful not to touch the muffler.

- 1- Remove the spark plug cap.
- 2- Clean any dirt from around the spark plug base.
- 3- Use a spark plug wrench to remove the spark plug.
- 4- Visually inspect the spark plug.

Discard it if the insulator is cracked or chipped. Clean the spark plug with a wire brush if it is to be reused.

- 5- Measure the plug gap with a feeler gauge.

Correct as necessary by carefully bending the side electrode.

THE GAP SHOULD BE: 0.70-0.80 MM (0.028-0.031 IN)

- 6- Check that the spark plug washer is in good condition, and thread the spark plug in by hand to prevent cross-threading.

- 7- After the spark plug is seated, tighten with a spark plug wrench to compress the washer.

-If installing a new spark plug, tighten 1/2turn after the spark plug seats to compress the washer. If reinstalling a used spark plug, tighten 1/8-1/4 turn after the spark plug seats to compress the washer.

NOTICE:

The spark plug must be securely tightened. An improperly tightened spark plug can become very hot and could damage the engine.

Never use spark plug which have an improper heat range. Use only the recommended spark plugs or equivalent.

TRANSPORTING/STORAGE

When transporting the generator, turn the engine switch and the fuel valve OFF. Keep the generator level to prevent fuel spillage. Fuel vapor or spilled fuel may ignite.

WARNING!

Before storing the unit for an extended period:

- 1- Be sure the storage area is free of excessive humidity and dust.
- 2- Service according to the table below:

TRANSPORTING/STORAGE

| STORAGE TIME | RECOMMENDED SERVICE PROCEDURE TO PREVENT HARO STARTING |
|--|---|
| Less than 1 month | No preparation required |
| 1 to 2 months | Fill with fresh gasoline and add gasoline conditioner. |
| 2 months to 1 year | Fill with fresh gasoline and add gasoline conditioner. Drain the carburetor float bowl. |
| 1 year or more | Fill with fresh gasoline and add gasoline conditioner*. Remove the spark plug. Put a tablespoon of engine oil into the cylinder. Turn the engine slowly with the pull rope to distribute the oil. Reinstall the spark plug. Change the engine oil. After removal from storage, drain the stored gasoline into a suitable container, and fill with fresh gasoline before starting. |
| Use gasoline conditioners that are formulated to extend storage life. Contact your authorized generator dealer for conditioner recommendations. | |

STORAGE

1- Drain the carburetor by loosening the screw. Drain the gasoline into a suitable container.

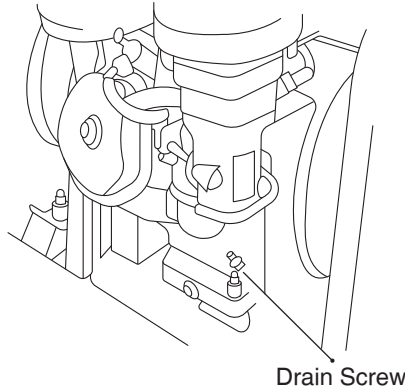

2- Change the engine oil .

3- Remove the spark plug, and pour about a tablespoon of clean engine oil into the cylinder. Crank the engine several revolutions to distribute the oil, then reinstall the spark plug.

4- Slowly pull the starter grip until resistance is felt. At this point, the piston is coming up on its compression stroke and both the intake and exhaust valves are closed. Storing the engine in this position will help to protect it from internal corrosion.

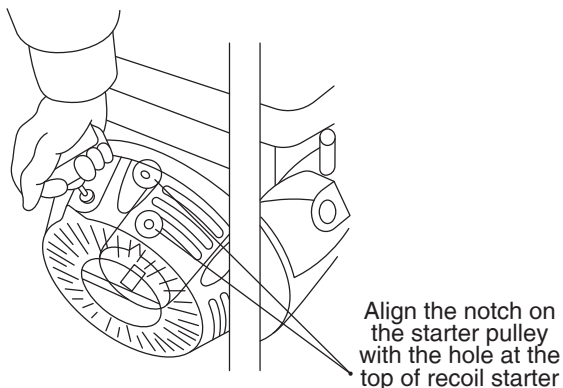

Ronix[®]
Premium Quality