

Ronix[®]

Premium Quality

GASOLINE GENERATOR 3200W RH-4705

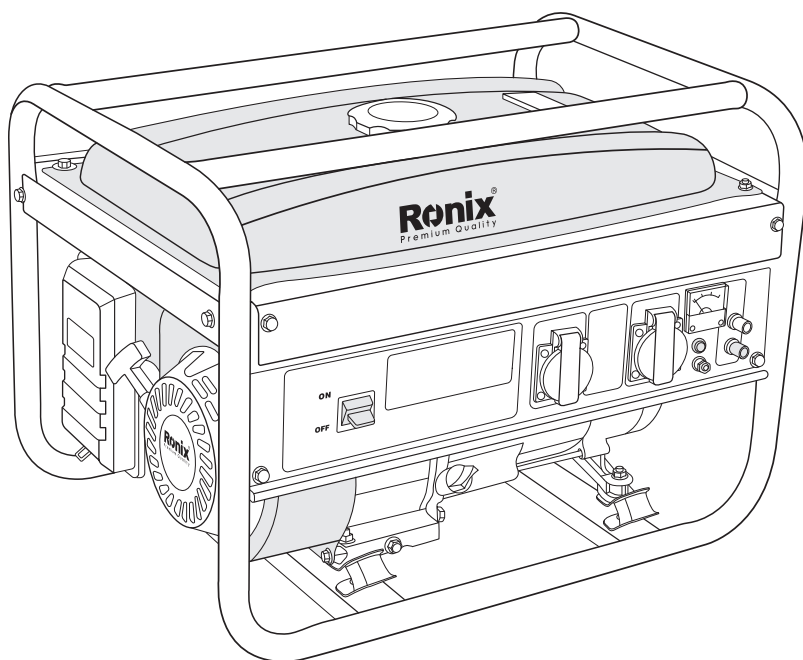

SPECIFICATIONS

Generator	Type		Single Phase
	Voltage	50Hz	220V
	Max Power		3200W
	Rated Power		2800-3000W
Engine	Model		LB170F
	Type		4stroke Air Cooled
	Displacement		210cc
	Continues Operation		10H
	Fuel		Unleaded Petrol
Spec	Fuel Tank Capacity		15L
	Weight		38Kg

PARTS LIST

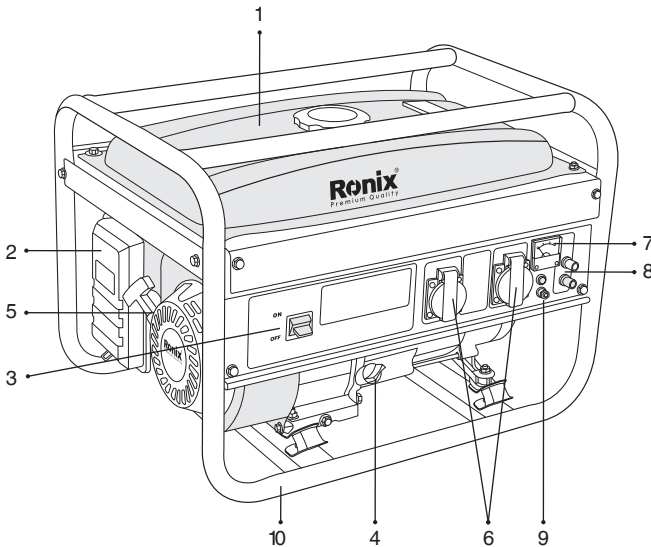

- 1- fuel tank
- 2- Air filter cover
- 3- Engine switch
- 4- Oil plug
- 5- Recoil starter handle
- 6- Ac socket
- 7- Voltmeter
- 8- Dc output
- 9- Earth
- 10- Frame

FOREWORD

WARNING!

- Indicates a possibility of death or serious injury if instructions are not followed.

WARNING!

- Indicates a strong possibility of severe personal injury, loss of life and equipment damage if instructions are not followed.

CAUTION:

- Indicates a possibility of personal injury or equipment damage if instructions are not followed.

NOTE:

- Gives helpful information.
- If a problem should arise, or if you have any questions about the generator, consult an authorized dealer or service shop

WARNING!

- The generator is designed to give safe and dependable service if operated according to instructions.

- Do not operate the generator before you have read and understood the instructions. Failure to do so could result in death, personal injury or equipment damage.

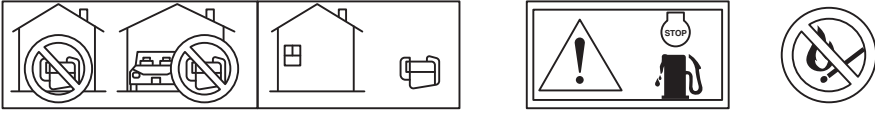

SAFETY INSTRUCTIONS

- Please make sure you review each precaution carefully.

⚠ WARNING!

- Do not operate the generator near gasoline or gaseous fuel because of the potential danger of explosion or fire.
 - Do not fill the fuel tank with fuel while the engine is running. Do not smoke or use open flame near the fuel tank. Be careful not to spill fuel during refueling. If fuel is spilt, wipe it off and let dry before starting the engine.



⚠ WARNING!

- Do not place in flammables near the generator.
 - Be careful not to place fuel, matches, gunpowder, oily cloths, straw, trash, or any other in flammables near the generator.

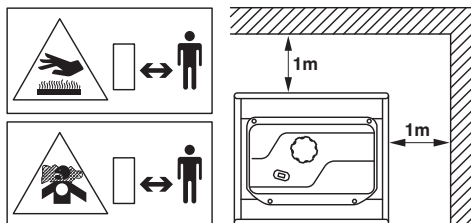

⚠ WARNING!

- Do not operate the generator inside a room, cave, tunnel, or other insufficiently ventilated area.
- Always operate it in a well-ventilated area, otherwise the engine may become overheated, and the poisonous carbon monoxide gas, an odorless, colorless, poison gas, contained in the exhaust gas will endanger human lives.
- Operate generator only outdoors and far from open windows, doors, ventilation intakes and other openings.
- Keep the generator at least 1 meter (3 feet) away, including overhead, from any structure or building use.

⚠ WARNING!

- Do not enclose the generator nor cover it with a box.
- The generator has a built-in forced air cooling system, and may become overheated if it is enclosed. If generator has been covered to protect it from the weather during non use, be sure to remove it and keep it well away from the area during generator use.

⚠ WARNING!

- Operate the generator on a level surface.
- It is not necessary to prepare a special foundation for the generator. However, the generator will vibrate on an irregular surface, so choose a level place without surface irregularities.
- If the generator is tilted or moved during operation, fuel may spill and/or the generator may tip over, causing a hazardous situation.
- Proper lubrication cannot be expected if the generator is operated on a steep incline or slope. In such a case, piston seizure may occur even if the oil is above the upper level.

⚠ WARNING!

- Pay attention to the wiring or extension cords from the generator to the connected device if the wire is under the generator or in contact with a vibrating part, it may break and possibly cause a fire, generator burnout,

or electric shock hazard.

- Replace damaged or worn cords immediately.

⚠ WARNING!

- Do not operate in rain, in wet or damp conditions, or with wet hands.
- The operator may suffer severe electric shock if the generator is wet due to rain or snow.

⚠ WARNING!

- If wet, wipe and dry it well before starting. Do not pour water directly over the generator, nor wash it with water.

⚠ WARNING!

- Be extremely careful that all necessary electrical grounding procedures are followed during each and every use. Failure to do so can be fatal.

⚠ WARNING!

- Do not contact the generator to a commercial power line. Connection to a commercial power line may short circuit the generator and ruin it or cause electric shock hazard. Use the transfer switch for connecting to domestic circuit.

⚠ WARNING!

- no smoking while handling the battery. The battery emits flammable hydrogen gas, which can explode if exposed to electric arcing or open flame.

- Keep the area well-ventilated and keep open flames/sparks away when handling the battery. Keep the area well-ventilated and keep open flames/sparks away when handling the battery.



⚠ WARNING!

- Engine becomes extremely hot during and for some time after operation.
- Keep combustible materials well away from generator area.
- Be very careful not to touch any parts of the hot engine especially the muffler area or serious burns may result.

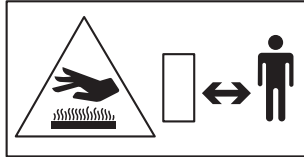

⚠ WARNING!

- Keep children and all bystanders at a safe distance from work areas.

⚠ WARNING!

- It is absolutely essential that you know the safe and proper use of the power tool or appliance that you intend to use. All operators must read, understand and follow the tool/appliance owners manual. Tool and appliance applications and limitations must be understood. Follow all directions given on labels and warnings. Keep all instruction manuals and literature in a safe place for future reference.

⚠ WARNING!

- Use only “LISTED” extension cords.
- When a tool or appliance is used outdoors, use only extension cords marked “For Outdoor Use”. Extension cords, when not in use should be stored in a dry and well ventilated area.

⚠ WARNING!

- Always switch off generator’s AC circuit breaker and disconnect tools or appliances when not in use before servicing, adjusting, or installing accessories and attachments.

⚠ CAUTION:

- Make sure the engine is stopped before starting any maintenance, servicing or repair.
- Make sure maintenance and repair of the generator set are performed by properly trained personnel only.

PRE-OPERATION CHECKS

■ CHECK ENGINE OIL

- Before checking or refilling oil, be sure generator is located on stable and level surface with engine stopped.
- Remove oil filler cap and check the engine oil level.
- If oil level is below the lower level line, refill with suitable oil (see table) to upper level line. Do not screw in the oil filler cap when checking oil level.

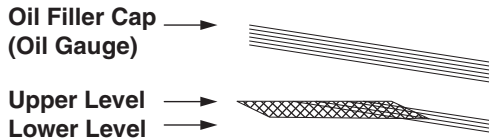

- Change oil if contaminated. (See “How-To” Maintenance.)
- Oil capacity (Upper level): 0.6L/0.15Gal

■ RECOMMENDED ENGINE OIL:

- Use 4-stroke automotive detergent oil of API service class SE or higher grade (SG, SH or SJ is recommended). SAE 10W-30 or 10W-40 is recommended for general, all-temperature use. If single viscosity oil is used, select the appropriate viscosity for the average temperature in your area.

Single Grade	5W						
	10W						
Multigrade	10W-30						
	10W-40						
Ambient Temperature	-20	-10	0	10	20	30	40° C
	-4	14	32	50	68	86	104° F

CHECK ENGINE FUEL.

⚠ WARNING!

- Do not refuel while smoking or near open flame or other such potential fire hazards. Otherwise fire accident may occur.

⚠ NOTE:

THIS ENGINE IS CERTIFIED TO OPERATE ON AUTOMOTIVE UNLEADED GASOLINE.

- Check fuel level at fuel level gauge.
- If fuel level is low, refill with unleaded automotive gasoline.
- Be sure to use the fuel filter screen on the fuel filter neck.

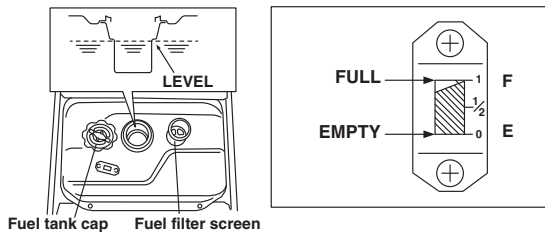

■ FUEL AMOUNT

Up to "LEVEL" position: (15L/3.95Gal)

⚠ WARNING!

- Make sure you review each warning in order to prevent fire hazard.
- Do not refill tank while engine is running or hot.
- Close fuel valve before refueling with fuel.
- Be careful not to admit dust, dirt, water or other foreign objects into fuel.
- Wipe off spilled fuel thoroughly before starting engine.
- Keep open flames away.

■ CHECKING COMPONENT PARTS

- Check following items before starting engine:
- Fuel leakage from fuel hose, etc.

- Bolts and nuts for looseness.
- Components for damage or breakage.
- Generator not resting on or against any adjacent wiring.

CHECK GENERATOR SURROUNDINGS

⚠ WARNING!

Make sure you review each warning in order to prevent fire hazard.

- Keep area clear of in flammables or other hazardous materials.
- Keep generator at least 3 feet (1 meter) away from buildings or other structures.
- Only operate generator in a dry, well ventilated area.
- Keep exhaust pipe clear of foreign objects.
- Keep generator away from open flame. No smoking!
- Keep generator on a stable and level surface.
- Do not block generator air vents with paper or other material.

GROUNDING THE GENERATOR

- To ground the generator to the earth, connect the grounding log of the generator to the grounding spike driven into the earth or to the conductor which has been already grounded to the earth.

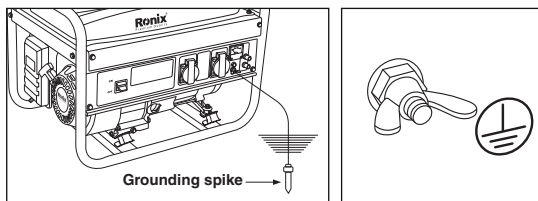

OPERATING PROCEDURES

■ STARTING THE GENERATOR

⚠ CAUTION:

- Check the oil level before each operations as outlined by the article “CHECK ENGINE OIL”
- Turn the Engine switch to the position “RUN”

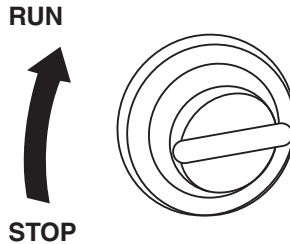

- Turn the AC circuit breaker to the position “OFF”.

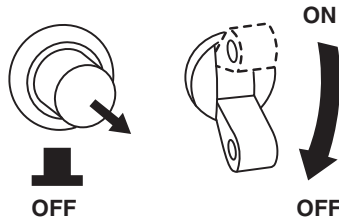

- Open the fuel valve.

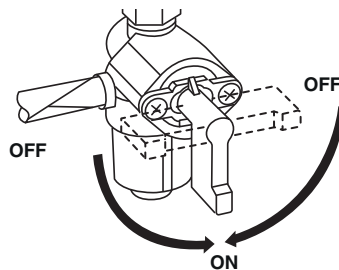

- Set choke lever to close if the engine

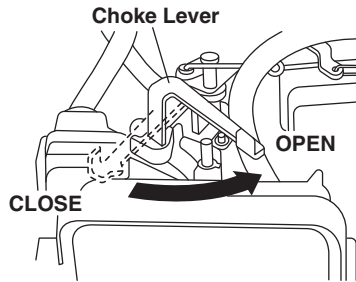

- Recoil starter model

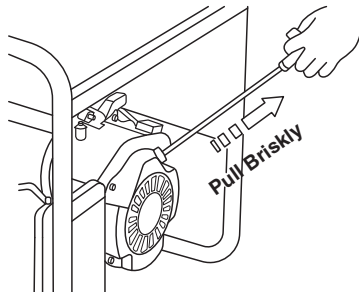

- Pull the starter handle slowly until passing the compression point (resistance will be felt), then return the handle to its original position and pull briskly. procedures with choke lever returned to “OPEN” position.
- Do not fully pull out the rope.
- After starting, allow the starter handle to return to its original position while still holding the handle.

USING ELECTRIC POWER

⚠ WARNING!

- Make sure that the appliance is switched OFF before connecting it to the generator.
- Do not move the generator while it is running.
- Be sure to ground the generator if the connected appliance is grounded.

- Failure to ground unit lead to electrical shock.

■ AC APPLICATION

- Turn off the switch (es) of the electrical appliance (s) before connecting to the generator
- Insert the plug (s) of the electrical appliance (s) into the receptacle
- Turn the AC circuit breaker to the position “ON”.
- Turn on the switch of the appliance.

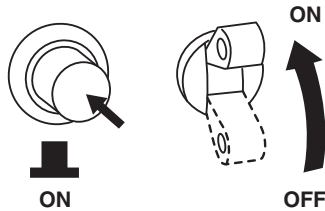

■ STOPPING THE ENGINE

- Turn of the switch of load.
- Switch off generator’s AC breaker.
- Disconnect tool or appliance.

⚠ NOTE:

- Allow the engine about 3 minutes to cool down at no-load before stopping.

DC APPLICATION (ONLY FOR CHARGING 12 VOLT BATTERY)

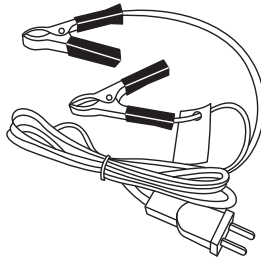

- The exclusive DC cable is come with your generator set (included in the package).

■ DC Circuit Breaker

- DC circuit breaker is turned off to shut down the DC power, when the DC is over the usage range or the battery is defective.
- Check the generator and/or battery for overloading or defect, and turn on the DC circuit breaker after no problem and defect are found out.

■ CONNECTION OF EXCLUSIVE DC CABLE:

- Connect positive (red) clip of DC cable positive (+) terminal on battery.
- Connect negative (black) clip of DC cable to negative (-) terminal on battery.

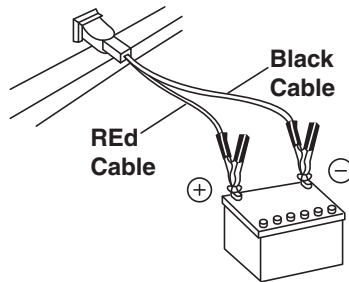

BATTERY CHARGING PROCEDURES:

- Stop engine.
- Remove all connections from battery.
- Insert the plug of exclusive DC cable into DC receptacle.
- Connect positive (red) clip of DC cable to positive (+) terminal on battery, and then connect negative (black) clip of DC cable to negative (-) terminal on battery.
- Take out all plugs at the battery electrolyte fluid filler ports.
- Start engine.
- Make sure that the DC circuit breaker is in the ON position.
- Battery charging will be started.

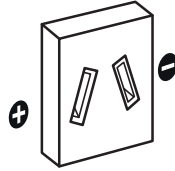

DC receptacle

⚠ CAUTION:

- Do not use both AC and DC output at the same time.
- Install correct positive (red) or negative (black) cable to the correct polarity on the battery.
- Connect and disconnect DC cable with engine stopped.
- An explosive hydrogen gas is discharged through vent holes in the battery during the charging process.

Do not allow spark or open flame around the generator or battery during the charging process.

- Electrolyte fluid contains sulphuric acid. And so the fluid can burn eyes and clothing. Be extremely careful to avoid contact.

If injured, wash the affected area immediately with large quantities of water and consult a doctor for treatment.

- Charging time is varied according to the kind of battery and discharged level of battery.

Measure the specific gravity of electrolyte fluid by means of hydrometer every one hour during battery charging.

Make sure if the DC circuit breaker is not turned off.

Battery charging is completed when the specific gravity is in the range of 1.26 to 1.28

STOPPING THE GENERATOR

- Turn off the power switch of the electric equipment and unplug the cord from receptacle of the generator.

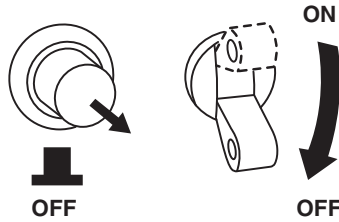

- Turn the AC circuit breaker to the “OFF” position.
- Allow the engine about 3 minutes to cool down at no-load before stopping.

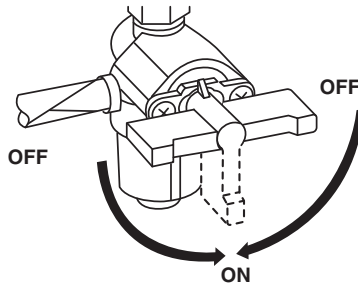

RECOIL STARTER MODEL

- Turn the engine switch to the position “STOP”.

ELECTRIC STARTER MODEL

- Turn the key switch to the STOP position.
- Close the fuel valve.

OIL SENSOR (IF APPLICABLE)

- The oil sensor detects the fall in oil level in the crankcase and automatically stops the engine when the oil level falls below a predetermined level.
- When engine has stopped automatically, switch off generator’s AC circuit breaker, and check the oil level.
- Refill engine oil to the upper level as instructed and restart the engine.
- If the engine does not start by usual starting procedures, check the oil level.

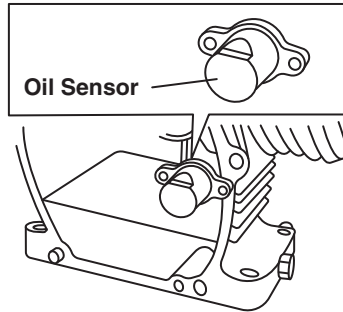

WATTAGE INFORMATION

- Depending on their wattage output, generators will run anything from a small lamp to a number of large appliances. To determine the size generator you will need, total the wattage of the maximum number of items you will be running simultaneously.
- For example: running a 100 watt light bulb, a 200 watt slow cooker, a 1,200 watt refrigerator with a start up wattage of 2,900 watts and a 750 watt TV would require 3,950 watts.
- Some appliances need a “surge” of energy when starting.
- This means that the amount of electrical power needed to start the appliance may exceed the amount needed to maintain its use.
- Electrical appliances and tools normally come with a label indicating voltage, cycles/ Hz, amperage (amps) and electrical power needed to run the appliance or tool.
- Check with your nearest dealer or service center with questions regarding power surge of certain appliances or power tools.
- Electrical loads such as incandescent lamps and hot plates require the same wattage to start as is needed to maintain use- Loads such as fluorescent lamps require 1.2 to 2 times the indicate wattage during start-up.
- Loads for mercury lamps require 2 to 3 times the indicated wattage during start-up.
- Electrical motors require a large starting current. Power requirements depend on the type of motor and its use. Once enough “Surge” is attained

to start the motor, the appliance will require only 50% to 30% of the wattage to continue running.

- Most electrical tools require 1.2 to 3 times their wattage for running under load during use. For example, a 5,000 watt generator can power a 1800 to 4000 watt electrical tool.
- Loads such as submersible pumps and air compressors require a very large force to start. They need 3 to 5 times the normal running wattage in order to start.
- For example, a 5,000 watt generator would only be able to drive a 1,000 to 1,700 watt pump.

MAINTENANCE SCHEDULE

■ DAILY INSPECTION

- Before running the generator, check the following service items:

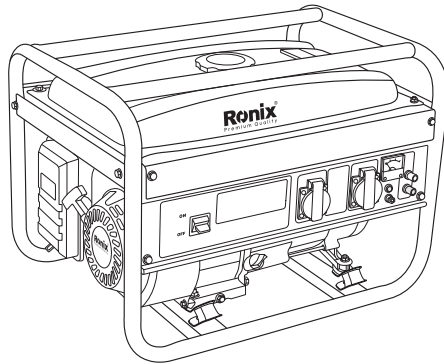

■ PERIODIC MAINTENANCE

Periodic maintenance is vital to safe and efficient operation of your generator check the table below for periodic maintenance intervals.

IT IS ALSO NECESSARY FOR THE USER OF THIS GENERATOR TO CONDUCT THE MAINTENANCE AND ADJUSTMENTS ON THE EMISSION RELATED PARTS LISTED BELOW TO KEEP THE EMISSION CONTROL SYSTEM EFFECTIVE.

The emission control system consists of the following parts:

- Carburetor and internal parts
- Intake manifold, if applicable
- Air cleaner elements
- Spark plug
- Magneto or electronic ignition system
- Exhaust manifold, if applicable
- Hoses, belts, connectors, and assemblies

- The maintenance schedule indicated in the table is based on the normal generator operation. should the generator be operated in extremely dusty condition or in heavier loading condition, the maintenance intervals must be shortened depending on the contamination of oil, clogging of filter elements, wear of parts, and so on.

PERIODIC MAINTENANCE SCHEDULE TABLE

Maintenance Items	Every 8 hours (Daily)	Every 50 hours (Weekly) Every	Every 200 hours (Monthly)	Every 500 hours	Every1000 hours
Clean generator and check bolt and nuts	- (Daily)				
Check and refill engine oil	- (Refill daily up to upper level)	Change engine oil (Note1)	Initial 20 hours	Every 100 hours	
Clean spark plug		(Every 100 hours)			
Clean air cleaner			•		
Replace air cleaner element			•		
Clean fuel filter			•		

Clean and adjust spark plug and electrodes				•	
Replace spark plug				•	
Remove carbon from cylinder head (*Note 2)				•	
Check and adjust valve clearance (*Note2)				•	
Clean and adjust carburetor (*Note 2)				•	
Check and replace carbon brushes					• (Yearly)
Replace fuel lines					•
Overhaul engine (*Note 2)					•
Check AC receptacles	• (Daily)	•			
Check DC terminal	• (Daily)				
Check engine switch	• (Daily)				
Check rotor	•				•
Check stator	•				•
Replace engine mount	•				•

⚠ NOTE:

- Initial oil change should be performed after first twenty (20) hours of operation. thereafter change oil every hundred (100) hours.
Before changing oil, check for a suitable way to dispose of old oil.

⚠ NOTE:

- As to the procedures for these items, please refer to the SERVICE MANUAL or consult your nearest service dealer.

PREPARATION FOR STORAGE

- The following procedures should be followed prior to storage of your generator for periods of 6 months or longer.
- Drain fuel from fuel tank carefully by disconnecting the fuel line. Gasoline left in the fuel tank will eventually deteriorate making engine starting difficult.
- Remove the carburetor float chamber and also drain the carburetor.
- Change engine oil.
- Check for loose bolts and screws, tighten them if necessary.
- Clean generator thoroughly with oiled cloth. Spray with preservative if available. **NEVER USE WATER TO CLEAN GENERATOR!**
- Pull starter handle until resistance is felt, leaving handle in that position.
- Store generator in a well ventilated, low humidity area.

TROUBLESHOOTING

- When generator engine fails to start after several attempts, or if no electricity is available at the output socket, check the following chart.
- If your generator still fails to start or generate electricity, contact your nearest dealer or service shop for further information or corrective procedures.

WHEN ENGINE FAILS TO START:

Check if choke lever is in its proper position.		Set the choke lever to "CLOSE" position.
Check if fuel valve is open.		If closed, open fuel valve.
Check fuel level.		If empty, refill fuel tank making sure not to overfill.
Check if engine switch is in OFF.		Turn engine switch to ON.
Check to make sure generator is not connected to an appliance.		If connected, turn off the power switch on the connected appliance and unplug.
Check spark plug for loose spark plug cap.		If loose, push spark plug cap back into place.
Check spark plug for contamination.		Remove spark plug and clean electrode.

WHEN NO ELECTRICITY IS GENERATED AT RECEPTACLE:

Check to make sure AC circuit breaker is in the "ON" position.		After making sure that the total wattage of the electrical appliance is within permissible limits and there are no defects in the appliance, turn the AC circuit breaker to the "ON" position. If breakers continue to actuate, consult your nearest servicing dealer.
Check AC receptacle and DC terminals for loose connection.		Secure connection if necessary.
Check to see if engine starting was attempted with appliances already connected to generator.		Turn off switch on the appliance, and disconnect cable from receptacle. Reconnect after generator has been started properly.
Low Power.		Carbon brushes are excessively worn

Ronix[®]
Premium Quality