

Ronix[®]

Premium Quality

PERIPHERAL PUMP 0.5HP

RH-4020

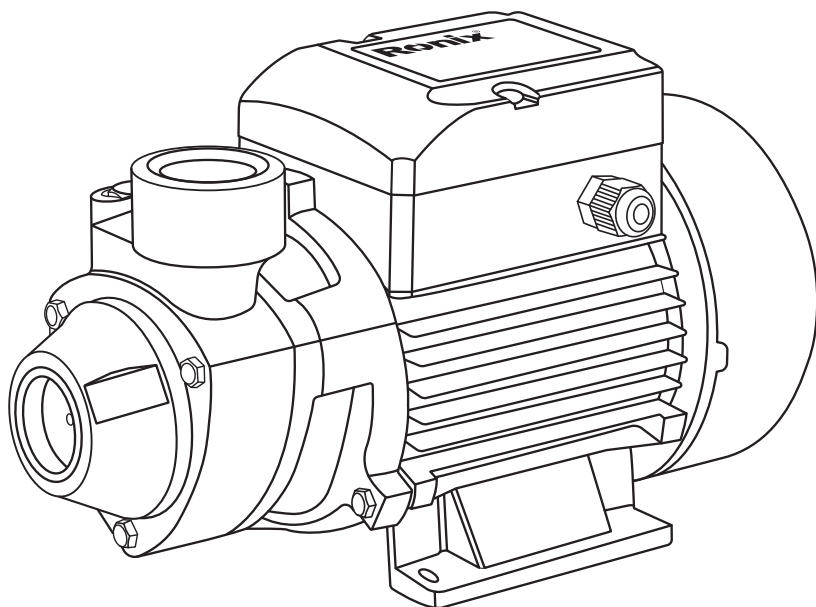

SPECIFICATION

Model	RH-4020
Voltage	220-240V
Frequency	50Hz
Power	0.5hp
Min.Flow	0.3m ³ /h
Max. Flow	1.9m ³ /h
Min.Head	3m
Suction heigh	8m
Inlet/outlet port diameter	1In x 1In
Max. liquid temperature	60°C
Max. head	35m
Max. Ambient temperature	40°C
Speed	2850RPM
Working Pressure	3.5BAR
Protection level	IP44
Pump housing material	CAST IRON
Insulation Class	CLASS B
Mechanical seal material	C/G
Safety system	Anti lock system for impeller
Motor housing material	ALUMINUM
Motor protection	Thermal protection
Coil winding material	COPPER
Weight	5.6kg
shaft material	SS304+45
Supplied In	Ronix color box

PART LIST

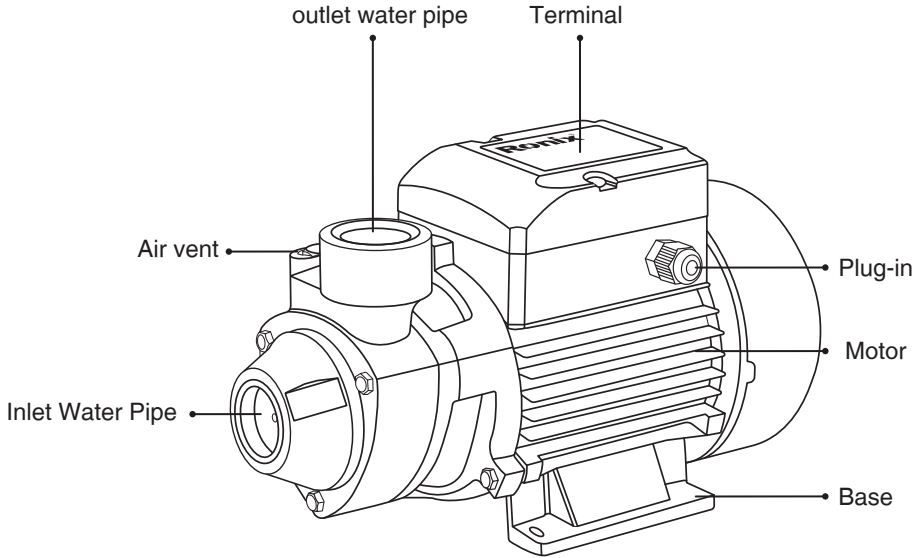

⚠ NOTE

In order to achieve the best performance of your product, please read this instruction manual carefully before using, and keep it for future reference.

⚠ CAUTION!

To reduce the risk of electric shock do not open this device, there are not serviceable parts for customers. Please refer any maintenance or Call Ronix service center

⚡ This sign means the existence of dangerous voltage at the inside of the unit, which states a risk of electric shock.

⚠ This sign means that there are important instructions of operation and handling in the manual that comes with this device.

GENERAL POWER TOOL SAFETY WARNINGS

WARNING!

- Read all safety warnings and all instructions. Failure to follow the warnings and instructions may result in electric shock, fire and or serious injury.
- Save all warnings and instructions for future reference.
- The term “power tool” in the warnings refers to your mains-operated (corded) power tools or battery operated (cordless) power tool.

■ WORK AREA SAFETY

- Keep work area clean and well lit. Cluttered or dark areas invite accidents.
- Don't operate power tools in explosive atmospheres, such as in the presence of flammable liquids, gases or dust. Power tools create sparks which may ignite the dust or fumes.
- Keep children and bystanders away while operating a power tool. Distractions can cause you to lose control.

■ ELECTRIC SAFETY

- Power tool plugs must match the outlet. Never modify the plug in any way. Don't use any adaptor plugs with earthed (grounded) power tools. Unmodified plugs and matching outlets will reduce risk of electric shock.
- Avoid body contact with earthed or grounded surfaces such as pipe, radiators, ranges and refrigerators. There is an increased risk of electric shock if your body is earthed or grounded.
- Don't expose power tools to rain or wet conditions. Water entering a power tool will increase the risk of electric shock.
- Don't abuse the cord. Never use the cord for carrying, pulling or unplugging the power tool. Keep cord away from heat, oil, sharp edges or moving parts. Damaged or entangled cords increased the risk of electric shock.
- When operating a power tool outdoors, use an extension cord suitable for outdoor use. Using a cord suitable for outdoor use will reduce the risk

of electric shock.

- If operating a power tool in a damp location is unavoidable, use a residual current device (RCD) protected supply. Use of an RCD reduces the risk of electric shock.

- Use of power supply via an RCD with a rated residual current of 30mA or less is always recommended.

■ PERSONAL SAFETY

- Stay alert, watch what you are doing and use common sense when operating a power tool. Don't use a power tool while you are tired or under the influence of drugs, alcohol or medication. A moment of inattention while operating power tools may result in serious personal injury.

- Use personal protective equipment. Always wear eye protection. Protective equipment such as dust mask, non-skid safety shoes, hard hat, or hearing protection used for appropriate conditions will reduce personal injuries.

- Prevent unintentional starting. Ensure the switch is in the off-position before connecting to power source and/or battery pack, picking up or carrying the tool. Carrying power tools with your finger on the switch or energizing power tools that have the switch on invites accidents.

- Remove any adjusting key or wrench before turning the power tool on. A wrench or a key left attached to a rotating part of the power tool may result in personal injury.

- Don't overreach. Keep proper footing and balance at all times. This enables better control of the power tool in unexpected situations.

- Dress properly. Don't wear loose clothing or jewelry. Keep your hair, clothing, and gloves away from moving parts. Loose cloths, jewelry or long hair can be caught in moving parts.

- If devices are provided for connection of dust extraction and collection facilities, ensure these are connected and properly used. Use of dust collection can reduce dust-related hazards.

POWER TOOL USE AND CARE

- Don't force the power tool. Use the correct power tool for your application. The correct power tool will do the job better and safer at the rate for which it was designed.
- Don't use the power tool if the switch doesn't turn it on and off. Any power tool that cannot be controlled with the switch is dangerous and must be repaired.
- Disconnect the plug from the power source and/or the battery pack from the power tool before making any adjustments, changing accessories, or storing power tools. Such preventive safety measures reduce the risk of starting the power tool accidentally.
- Store idle power tools out of the reach of children and don't allow persons unfamiliar with power tool or these instructions to operate the power tool. Power tools are dangerous in the hands of untrained users.
- Maintain power tools. Check for misalignment or binding of moving parts, breakage of parts and any other condition that may affect the power tool's operation. If damaged, have the power tool repaired before use. Many accidents are caused by poorly maintained power tools.
- Keep cutting tools sharp and clean. Properly maintained cutting tools with sharp cutting edges are less likely to bind and are easier to control.
- Use the power tool, accessories and tool bits etc. in accordance with the instruction, taking into account the working conditions and the work to be performed. Use of the power tool for operations different from those intended could result in a hazardous situation.

SERVICE

- Have your power tool serviced by Ronix Service Center. This will ensure that the safety of power tool is maintained.
- Follow instruction for lubricating and changing accessories.
- Keep handles dry, clean and free from oil and grease.

USE AND MAINTENANCE INSTRUCTIONS

Carefully follow the instructions below to obtain the best performance and a long service life from your pump.

Contact RONIX service center if you have any problem.

OPERATING CONDITIONS:

these pumps have been designed to pump neutral clean liquids in which no abrasive solids are suspended at temperatures of no more than 60°C

INSTALLATION:

The pumps must be installed in a dry well-ventilated place with an ambient temperature of no more than 40°C.

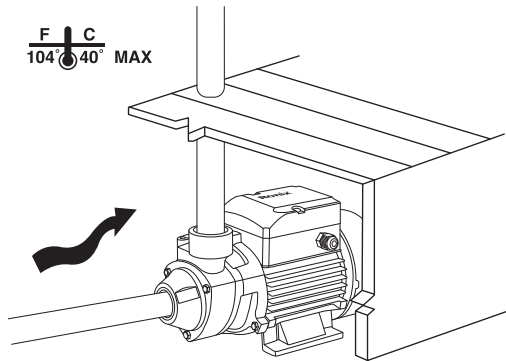

Fix the pump in place on a solid flat surface using suitable bolts to avoid vibration. The pump must be installed in a horizontal position to ensure, that the bearings operate correctly. The diameter of the intake pipe must not be smaller than that of the intake mouth. If the intake height exceeds 4 meters use a pipe with a larger diameter. The diameter of the delivery pipe must be chosen to suit the flow rate and pressure required at the take-off points.

The intake pipe must be slightly angled up towards the intake mouth to avoid the formation of air locks.

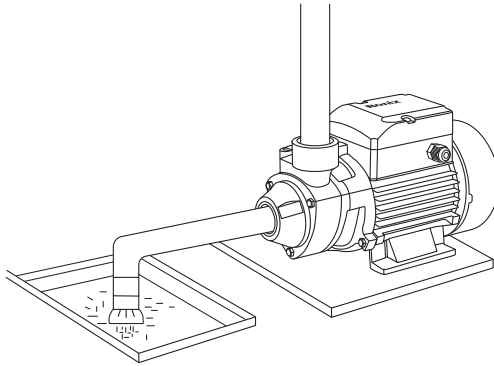

Make sure that the intake pipe is completely airtight and immersed in the water by at least half a meter to avoid the formation of vortexes. Always fit a foot valve at the end of the intake pipe. It is advisable to fit a non-return valve between the delivery mouth and flow rate adjustment gate valve to avoid dangerous water hammering in the event of the pump suddenly stopping. This measure is compulsory if the delivery water column is over 20 meters.

The pipes must always be fitted using the related brackets to avoid transmitting stress to the pump body. Take care not to damage any part by overtightening the pipes when fitting them.

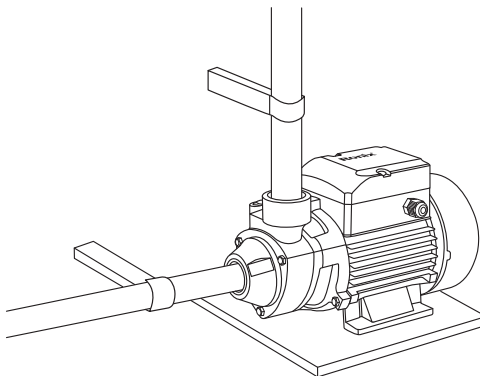

ELECTRICAL CONNECTIONS:

The installer is responsible for making the electrical connections to the mains supply in compliance with the relevant regulations in force;

- Make sure that the specifications on the pump rating plate and the rated line values are the same;

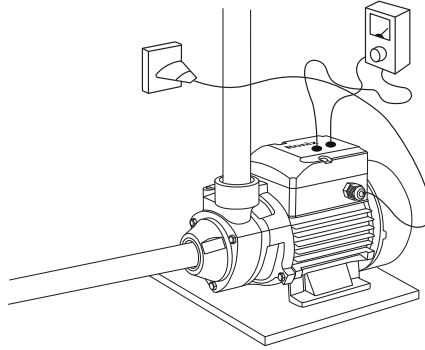

- Connect the pump to an effective earth circuit and then connect up the phases following the diagram on the terminal block cover or rating plate;

-Our single-phase motors are protected against overloads using a thermal device (overload cutout) fitted in the winding.

■ IMPORTANT:

Fill the pump completely with clean water before switching it on. The water should be poured in through the priming.

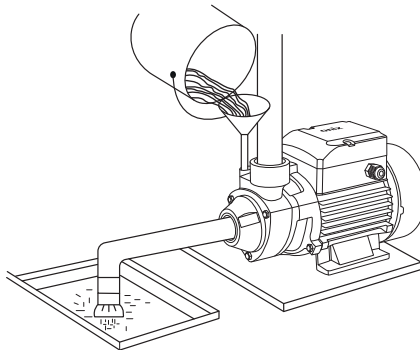

When you have completed the operation, screw the plug back in again and start the pump. The pump should be primed again whenever it has not been used for a long period of time or when air has made its way into the system.

■IMPORTANT:

Never run the pump empty. If this happens by mistake, switch the pump off, wait for it to cool down and then prime it using clean water.

■MAINTENANCE:

Our pumps do not require any maintenance provided one takes the following precautions; When there is a risk of freezing, empty the pump through the drain plug on the bottom of the pump body, making sure you prime it when subsequently starting it again; check that the foot valve is clean at regular intervals; if the pump is to remain unused for a long period of time (e.g.in the Winter),it is advisable to empty it completely, rinse it with clean water and store it in a dry place;

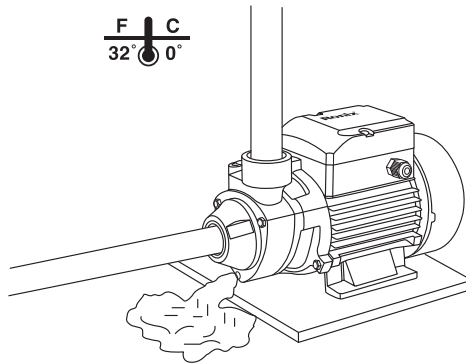

Never carry out any work on the pump without having first disconnected it from the mains supply.

Solution	Cause	Problem
Motor won't start	<ul style="list-style-type: none"> • No power • Impeller stuck 	<ul style="list-style-type: none"> • Check connections and voltage values • Call Ronix Service Center
Motor turns without pumping water	<ul style="list-style-type: none"> • Clogged filter Excessive intake height • Air in intake 	<ul style="list-style-type: none"> • Clean filter • Move pump closer to water outlet level • Check intake pipe is tight • Make sure foot valve is immersed by at least 50cm • Pump needs to be primed again
Flow rate insufficient	<ul style="list-style-type: none"> • Intake height at limit • filter partially clogged • Impeller blocked 	<ul style="list-style-type: none"> • Check intake height • Clean foot valve and if necessary whole intake pipe • Call Ronix Service Center
Tripped motor overload cutout	<ul style="list-style-type: none"> • Overheated motor • Impeller stuck 	<ul style="list-style-type: none"> • Check voltage and ventilation • Call Ronix Service Center

Ronix[®]
Premium Quality

www.ronixtools.com