

# Ronix<sup>®</sup>

Premium Quality

**BELT SANDER**

**9103**

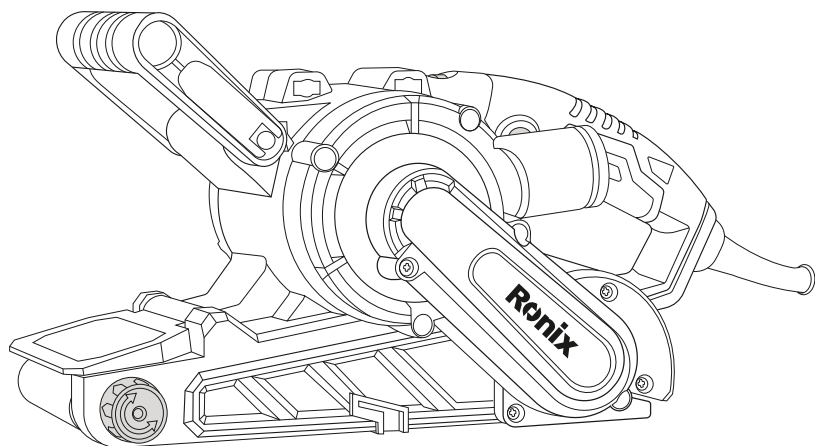

[www.ronixtools.com](http://www.ronixtools.com)

## TECHNICAL SPECIFICATION

Model No.	9103
Power	1050W
Voltage	220-240V
Frequency	50-60Hz
Belt Size	76x533mm
Belt Speed	150-360m/min
Weight	3.4Kg
Packing	Ronix Color Box
Accessories	Dust Bag

## PART LIST

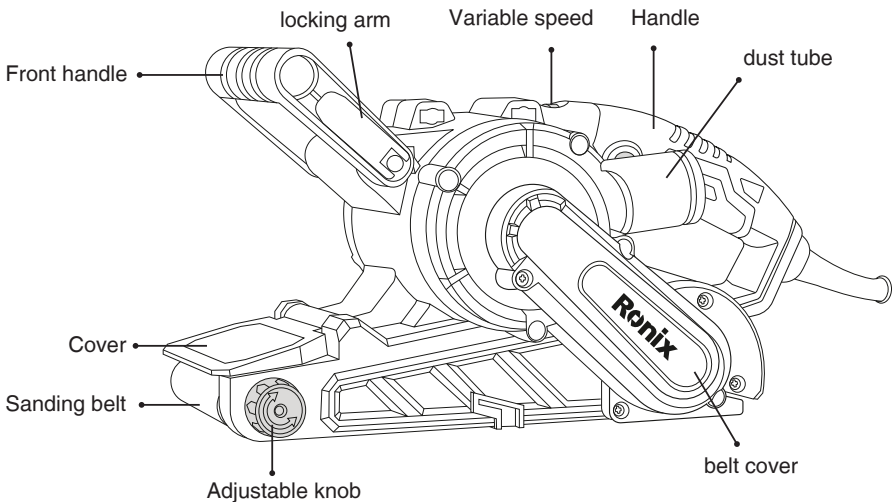

PLEASE READ BEFORE RETURNING THIS PRODUCT FOR ANY REASON.

SAVE THIS MANUAL FOR FUTURE REFERENCE.

KEY INFORMATION YOU SHOULD KNOW:

- Always start your belt sander before it is contact with the workpiece and do not switch it off until after it has been lifted from the workpiece.
- Always hold your belt sander with two hands.

## **SAFETY GUIDELINES-DEFINITIONS**

It is important for you to read and understand this manual. The information it contains related to protecting YOUR SAFETY and PREVENTING PROBLEMS. The symbols below are used to help you recognize this information.

### **DANGER!**

Indicated an imminently hazardous situation which, if not avoided, will result in death or serious injury.

### **WARNING!**

Indicates a potentially hazardous situation which, if not avoided, could result in death or serious injury.

### **CAUTION!**

Indicates a potentially hazardous situation which, if not avoided, may result

## **GENERAL POWER TOOL SAFETY WARNINGS**

### **WARNING!**

- Read all safety warning and all instructions.

Failure to follow the warning and instruction may result in electric shock, fire and/or serious injury.

**SAVE ALL WARNINGS AND INSTRUCTIONS FOR FUTURE REFERENCE**

The term “power tool” in the warning refers to your mains-operated (corded) power tool or battery-operated (cordless) power tool.

## ■ WORK AREA SAFETY

- Keep work area clean and well lit. Cluttered or dark areas lead to accidents.
- Do not operate power tools in explosive atmospheres, such as in the presence of flammable liquids, gases or dust. Power tools create sparks which may ignite the dust or fumes.
- Keep children and bystanders away while operating a power tool. Distractions can cause you to lose control.

## ■ ELECTRIC SAFETY

- Power tool plugs must match the outlet. Never modify the plug in any way. Do not use any adapter plugs with earthed (grounded) power tools. Unmodified plugs and matching outlets will reduce risk of electric shock.
- Avoid body contact with earthed or grounded surface such as pipes, radiators, ranges and refrigerators. There is an increased risk of electric shock if your body is earthed or grounded.
- Do not expose power tools to rain or wet conditions. Water entering a power tool will increase the risk of electric shock.
- Do not abuse the cord. Never use the cord for carrying, pulling or unplugging the power tool. Keep cord away from heat, oil, sharp edges or moving parts. Damaged or entangled cords increase the risk of electric shock.
- When operating a power tool outdoors, use an extension cord suitable for outdoor use. Use of a cord suitable for outdoor use reduces the risk of electric shock.
- If operating a power tool in a damp location is unavoidable, use a ground fault circuit interrupter (GFCI) protected supply. Use of a GFCI reduces the risk of electric shock.

## ■ PERSONAL SAFETY

- a- Stay alert, watch what you are doing and use common sense when operation a power tool. Do not use a power tool while you are tired or under the influence of drugs, alcohol or medication. A moment of inattention

while operating power tools may result in serious personal injury.

b- Use personal protective equipment. Always wear eye protection. Protective equipment such as dust mask, non skid safety shoes, hard hat, or hearing protection used for appropriate conditions will reduce personal injuries.

c- Prevent unintentional Starting. Ensure the switch is in the off position before connecting to power source and/or battery pack, picking up or carrying the tool. Carrying power tools with your finger on the switch or energizing power tools that have the switch on invites accidents.

d- Remove any adjusting key or wrench before turning the power tool on. A wrench or a key left attached to a rotating part of the power tool may result in personal injury.

e- Do not overreach. Keep proper footing and balance at all times. This enables better control of the power tool in unexpected situations.

f- Dress properly. Do not wear loose clothing or Jewelry. Keep your hair, clothing and gloves away from moving parts. Loose clothes, jewelry or long hair can be caught in moving parts.

g- If devices are provided for the connection of dust extraction and collection facilities, ensure these are connected and properly used. Use of dust collection can reduce dust-related hazards.

#### **■ POWER TOOL USE AND CARE**

a- Do not force the power tool. Use the correct power tool for your application. The correct power tool will do the job better and safer at the rate for which it was designed.

b- Do not use the power tool If the switch does not turn It on and off. Any power tool that cannot be controlled with the switch is dangerous and must be repaired.

c- Disconnect the plug from the power source and/or the battery pack from the power tool before making any adjustments, changing accessories, or storing power tools. Such preventive safety measures reduce the risk of starting the power tool accidentally.

d- Store idle power tools out of the reach of children and do not allow persons unfamiliar with the power tool or these Instructions to operate the

power tool. Power tools are dangerous in the hands of untrained users.

e- Maintain power tools. Check for misalignment or binding of moving parts, breakage of parts and any other condition that may affect the power tool's operation. If damaged, have the power tool repaired before use. Many accidents are caused by poorly maintained power tools.

f- Keep cutting tools sharp and clean. Properly maintained cutting tools with sharp cutting edges are less likely to bind and are easier to control.

g- Use the power tool, accessories and tool bits, etc. in accordance with these instructions, taking into account the working conditions and the work to be performed. Use of the power tool for operations different from those intended could result in a hazardous situation.

## ■ SERVICE

a- Have your power tool serviced by a qualified repair person using only identical replacement parts. This will ensure that the safety of the power tool is maintained.

### Belt Sander Safety Warnings

- Hold power tool by Insulated gripping surfaces, because the belt may contact its own cord. Cutting a "live" wire may make exposed metal parts of the tool "live" and could give the operator an electric shock.
- Always use proper eye protection and a respirator when sanding.
- Use clamps or another practical way to secure and support the work piece to a stable platform. Holding the work by hand or against your body leaves it unstable and may lead to loss of control.
- Sanding of lead-based paint is not recommended. See Sanding Lead Based Paint for additional information before sanding paint.
- Clean your tool out periodically.

## WARNING!

Some dust created by power sanding, sawing, and grinding, drilling, and other construction activities contains chemicals known to the State of California to cause cancer, birth defects or other reproductive harm. Some examples of these chemicals are:

- lead from lead-based paints,

- crystalline silica from bricks and cement and other masonry products, and
- arsenic and chromium from chemically-treated lumber.

Your risk from these exposures varies, depending on how often you do this type of work. To reduce your exposure to these chemicals: work in a well ventilated area, and work with approved safety equipment, such as those dust masks that are specially designed to filter out microscopic particles.

Avoid prolonged contact with dust from power sanding, sawing, grinding, drilling, and other construction activities. Wear protective clothing and wash exposed areas with soap and water. Allowing dust to get into your mouth, eyes, or lay on the skin may promote absorption of harmful chemicals.

 **WARNING!**

Use of this tool can generate and/or disperse dust, which may cause serious and permanent respiratory or other Injury. Always use NIOSH/ OSHA approved respiratory protection appropriate for the dust exposure. Direct particles away from face and body.

 **WARNING!**

ALWAYS use safety glasses. Everyday eye glasses are NOT safety glasses. Also use face or dust mask if cutting operation is dusty. ALWAYS WEAR CERTIFIED SAFETY EQUIPMENT:

 **CAUTION!**

Wear appropriate hearing protection during use. Under some conditions and duration of use, noise from this product may contribute to hearing loss.

## **SAVE THESE INSTRUCTIONS**

 **SAFETY WARNINGS AND INSTRUCTIONS: SANDERS**

- ALWAYS WEAR EYE AND RESPIRATORY PROTECTION.
- Clean your tool out periodically.

## **OTHER IMPORTANT SAFETY WARNINGS AND INSTRUCTIONS**

### **SANDING**

### **LEAD BASE PAINT**

Sanding of lead based paint is **NOT RECOMMENDED** due to the difficulty of controlling the contaminated dust. The greatest danger of lead poisoning is to children and pregnant Women.

Since it is difficult to identify whether or not paint contains lead without a chemical analysis, we recommend the following precautions when sanding any paint:

### **PERSONAL SAFETY**

- No children or pregnant women should enter the work area where the paint sanding is being done until all clean up is completed.
- A dust mask or respirator should be worn by all persons entering the work area. The filter should be replaced daily or whenever the wearer has difficulty breathing.

### **NOTE:**

Only those dust masks suitable for working with lead paint dust and fumes should be used. Ordinary painting masks do not offer this protection. See your local hardware dealer for the proper (NIOSH approved) mask.

- **NO EATING, DRINKING or SMOKING** should be done in the work area to prevent ingesting contaminated paint particles. Workers should wash and clean up **BEFORE** eating, drinking or smoking. Articles of food, drink, or smoking should not be left in the work area where dust would settle on them.

### **ENVIRONMENTAL SAFETY**

- Paint should be removed in such a manner as to minimize the amount of dust generated.



- Areas where paint removal is occurring should be sealed with plastic sheeting of 4 milsthickness.
- Sanding should be done in a manner to reduce tracking of paint dust outside the work area.

## **CLEANING AND DISPOSAL**

- All surfaces in the work area should be vacuumed and thoroughly cleaned daily for the duration of the sanding project. Vacuum filter bags should be changed frequently.
- Plastic drop cloths should be gathered up and disposed of along with any dust chips or other removal debris. They should be placed in sealed refuse receptacles and disposed of through regular trash pick-up procedures. During clean up, children and pregnant women should be kept away from the immediate work area.
- All toys, washable furniture and utensils used by children should be washed thoroughly before being used again.

## **MOTOR**

Be sure your power supply matches with nameplate marking. This information is printed on the nameplate. Lower voltage will cause loss of power and can result in over-heating. All tools are factory-tested; if this tool does not operate, check the power supply.

## **SAVE THESE INSTRUCTIONS**

## **ADJUSTMENTS**

### **WARNING!**

To prevent accidental operation, turn off and unplug sander before performing the following operations. Failure to do this could result in serious personal injury.

## 3 POSITION HANDLE - FIGURE 1

A locking mechanism on the side of the handle can be loosened to allow the handle to move. To adjust the handle, pull out on the locking arm (Figure 1) and move the handle to the desired position (Figure 1A). Once the handle is in position, push the locking arm in to lock the handle into position.

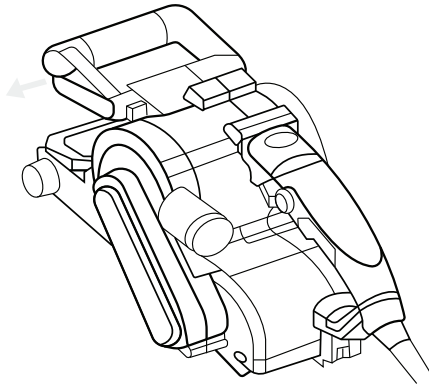

## 2 POSITION BELT COVER-FIGURE 2

The belt sander has an sanding belt cover at the front. When the handle is positioned in the uppermost position, this cover can be raised as shown in Figure 2 and locked in this position to:

- a.) Improve accessibility to narrow areas.
- b.) Allow the use of the smaller diameter front roller to sand with (normally the belt cover prevents this when in the “down” position).
- c.) Expose the top part of the belt for more versatile sanding.

To lower the belt cover, grasp the flange on the side and move it slightly in the direction shown in Figure 2 and return it to its closed position.

Note: The sanding belt cover cannot be locked in its raised position unless the bail handle is in the uppermost position.

**⚠ WARNING!**

The sanding belt is exposed when the belt cover is raised. Use extra caution when operating in this mode.

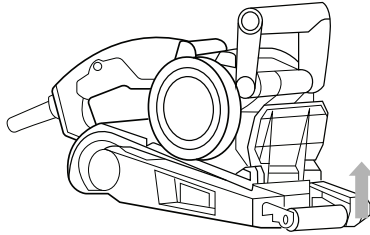

**ADJUSTING THE SANDING BELT TRACKING - FIGURE 3**

Turn the machine upside down (Figure3), hold it firmly with one hand, start motor and release switch immediately after observing tracking of sanding belt. If abrasive belt runs outward, turn tracking adjustment knob clockwise and counterclockwise if belt runs inward.

Belt life will be greatly increased by keeping the tracking adjustment set properly. To prevent the sanding belt from rubbing against the sander housing, keep the edge of the belt about 7/64 in. (2.7mm) to 13/64 in. (5, 1mm) from the housing as shown in figure 3.

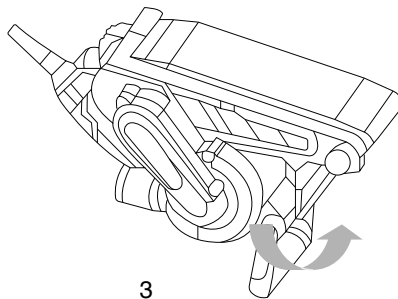

## CHANGING THE SANDING BELT - FIGURE 4 & 5

### **⚠ WARNING!**

To prevent accidental operation, turn off and unplug sander before changing the sanding belt.

Pull the lever shown in Figure 5 to release the tension on the sanding belt. Pull the sanding belt from the two rollers. Put the new 3 in. x 21 in. (75 x 533mm) sanding belt in position on the front and rear rollers (Figure 6). Ensure that the arrows on the sanding belt and on your belt sander are pointing in the same direction. Push the lever to the rear to tension the sanding belt.

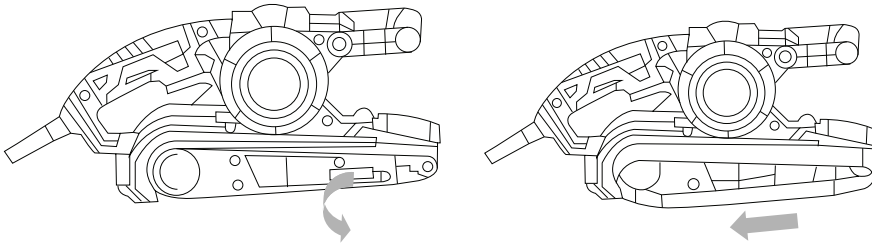

### **⚠ WARNING!**

To reduce the risk of injury, make sure belt is installed with arrows in proper direction of rotation. Failure to do this could result in the belt unraveling creating a hazardous condition.

## DUST COLLECTION - FIGURE 6.

### **⚠ WARNING!**

To prevent accidental operation, turn off and unplug sander before installing the dust bag.

When using your belt sander, dust and grit are produced. It is important to use a dust bag. Connect the dust bag by sliding the plastic opening of the bag down over the dust exhaust port of the sander as shown in Figure 6. To empty the dust bag, remove it from

the sander and unzip the bag over a trash container.

Note: A vacuum cleaner attachment is available as a service part at extra cost. To find your nearest Service Center location.

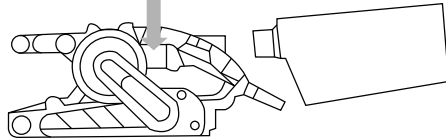

**⚠ WARNING!**

Fire hazard. Collected sanding dust from sanding surface coatings (polyurethane, linseed oil, etc.) can self-ignite in sander dust bag or elsewhere and cause fire. To reduce risk, empty bag frequently and strictly follow sander manual and coating manufacturer's instructions.

**⚠ WARNING!**

Fire hazard. When sanding wood that could contain nails or when sanding metal surfaces, do not use the dust bag or a vacuum cleaner because sparks are generated. Wear safety glasses and a dust mask. Due to the danger of fire, do not use your belt sander to sand magnesium surfaces. Do not use for wet sanding.

## **OPERATION**

### **■ USING YOUR BELT SANDER**

Always hold belt sander firmly with both hands while sanding. Note that sander bail handle can be adjusted to three different positions as previously discussed.

## **SWITCH - FIGURE 7**

To start your belt sander, press the on/off switch as shown in Figure 7. To stop your belt sander release the on/off switch. For continuous

operation, press the on/off switch then press the lock-on button (Figure 10) and release the on/off switch. To stop your belt sander, press the on/off switch to release the lock-on button. Release the on/off switch.

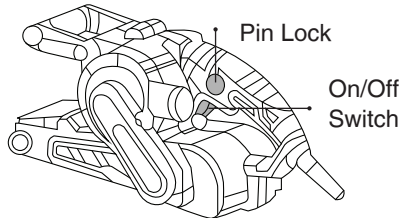

## HANDY HINTS

Always start your belt sander before it is in contact with the workpiece and do not switch it off until after it has been lifted from the workpiece. Always hold your belt sander with two hands.

Where possible, clamp the workpiece to a work bench or similar sturdy surface.

Use the correct grit sanding belt for your application. The following table is a suggested list of belt grits to use with different materials.

MATERIAL	BELT GRIT
Solid Wood	80
Veneer	150
Chipboard	60/80
Plastic	100
Steel	80 (remove dust bag)
Paint Removal	40/60
Balsa Wood	100
Acrylic	100

## TOOL CARE AND MAINTENANCE

Never apply excessive force when you use your belt sander. Too much force can result in overload and cause damage to the motor or the workpiece. If your belt sander becomes too hot, operate it without load for 2 minutes. Always keep the air cooling vents clear. To clean your belt sander, proceed as follows:

### **WARNING!**

To prevent accidental operation, turn off and unplug sander before performing the following operations. Failure to do this could result in serious personal injury.

- Use a clean dry paint brush to clear vents and ducts.
- Clean the housings using a clean damp cloth (do not use solvents, gas or turpentine.)

### **IMPORTANT:**

To assure product SAFETY and RELIABILITY, repairs, maintenance and adjustment should be performed by authorized service centers or other qualified service personnel, always using identical replacement parts.

## ACCESSORIES

Use only 3 in. x 21 in. (75 x 533mm) sanding belts. Recommended accessories for use with your tool are available at extra cost from your local dealer or authorized service center.

### **WARNING!**

The use of any accessory not recommended for use with this tool could be hazardous.





**Ronix**<sup>®</sup>  
Premium Quality

[www.ronixtools.com](http://www.ronixtools.com)