

Ronix[®]
Premium Quality

**BACKPACK GASOLINE BRUSH CUTTER
4552B**

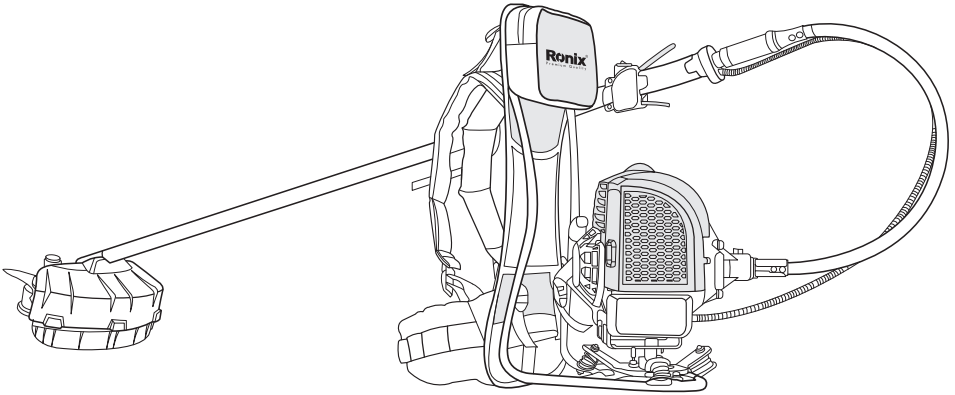

SPECIFICATIONS

Model	4552B
Engine Type	2-Stroke
Engine Power	1.5KW
Displacement	51.7cc
Fuel Capacity	1000ml
Power Source	Gasoline
Idling Speed Range	3100 ±400 R/MIN
Ignition	CDI
Two-cycle Oil/Gasoline Mixing Ratio	1:35
Shaft Type	Flexible Shaft
Working Pole Diameter	26mm
Cutting Capacity	Brush cutter: 255mm Grass trimmer: 430mm
Includes	3T metal blade, Nylon trimming head, Guard, Shoulder harness, Mixing oil bottle, Hex key
Supplied in	Ronix color box

PARTS LIST

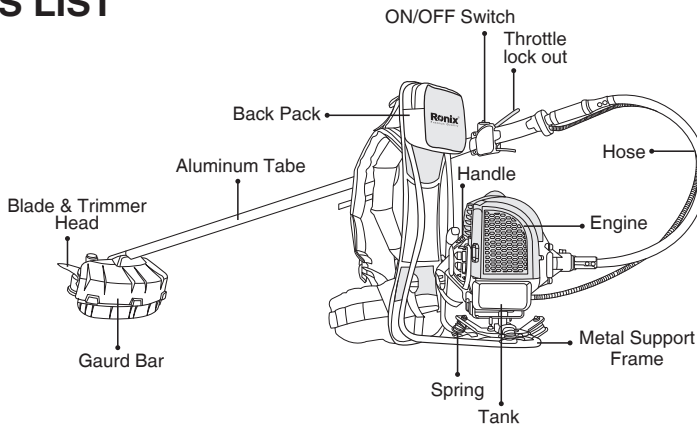

GENERAL SAFETY TIPS

The machine is only designed for cutting bushes and trimming grass. The only accessories you can operate with this engine unit are the cutting attachments we recommend in the chapter on Technical data.

Never use the machine if you are tired, if you are ill, if you have drunk alcohol, or if you are taking medication that could affect your vision, your judgement or your co-ordination.

Wear personal protective equipment. See instructions under the heading «Personal protective equipment».

Never use a machine that has been modified in any way from its original specification.

Never use a machine that is faulty. Carry out the checks, maintenance and service instructions described in this manual. Some maintenance and service measures must be carried out by trained and qualified specialists. See instructions under the heading «Maintenance».

All covers, guards and handles must be fitted before starting. Ensure that the spark plug cap and ignition lead are undamaged to avoid the risk of electric shock.

The machine operator must ensure that no people or animals come closer than 15 meters while working.

WARNING!

This machine produces an electromagnetic field during operation. This field may under some circumstances interfere with active or passive medical implants. To reduce the risk of serious or fatal injury, we recommend persons with medical implants to consult their physician and the medical implant manufacturer before operating this machine.

WARNING!

The exhaust gases emitted from engine contain dangerous carbon monoxide.

Running an engine in a confined or badly ventilated area can result in

death due to asphyxiation or carbon monoxide poisoning.

PERSONAL PROTECTIVE EQUIPMENT

▲ IMPORTANT:

- A brush cutter or trimmer can be dangerous if used incorrectly or carelessly, and can cause serious or fatal injury to the operator or others. It is extremely important that you read and understand the contents of this operator's manual.
- You must use approved personal protective equipment whenever you use the machine. Personal protective equipment cannot
- eliminate the risk of injury but it will reduce the degree of injury if an accident does happen. Ask your dealer for help in choosing the right equipment.

▲ IMPORTANT:

Listen out for warning signals or shouts when you are wearing hearing protection. Always remove your hearing protection as soon as the engine stops.

■ HELMET

A protective helmet where there is a risk of falling objects

■ HEARING PROTECTION

Wear hearing protection that provides adequate noise reduction.

■ EYE PROTECTION

Always wear approved eye protection. If you use a visor, then you must also wear approved protective goggles. Approved protective goggles must comply with standard ANSI Z87.1 in the USA or EN 166 in EU countries.

■ GLOVES

Gloves should be worn when necessary, e.g., when fitting cutting attachments.

■ BOOTS

Wear boots with steel toe-caps and non-slip sole.

■ CLOTHING

Wear clothes made of a strong fabric and avoid loose clothing that can catch on twigs and branches. Always wear heavy, long pants. Do not wear jewelers, shorts sandals or go barefoot. Secure hair so it is above shoulder level.

■ FIRST AID KIT

Always have a first aid kit nearby.

MACHINE'S SAFETY EQUIPMENT

This section describes the machine's safety equipment, its purpose, and how checks and maintenance should be carried out to ensure that it operates correctly. See the "What is what?" section to locate where this equipment is positioned on your machine.

The life span of the machine can be reduced and the risk of accidents can increase if machine maintenance is not carried out correctly and if service and/or repairs are not carried out professionally. If you need further information, please contact your nearest service workshop.

IMPORTANT:

All servicing and repair work on the machine requires special training. This is especially true of the machine's safety equipment. If your machine fails any of the checks described below you must contact your service agent. When you buy any of our products we guarantee the availability

of professional repairs and service. If the retailer who sells your machine is not a servicing dealer, ask him for the address of your nearest service agent.

⚠ IMPORTANT:

- Never use a machine with faulty safety equipment. The machine's safety equipment must be checked and maintained as described in this section. If your machine fails any of these checks, contact your service agent to get it repaired.
- Secure the machine during transport to prevent loss of fuel, damage or injury;
- Cleaning and maintenance before storage, including the use of guards on cutting attachments with metal blades;
- Use of a transport cover for metal blades during transport and storage;

⚠ ALERT!

National regulation can restrict the use of the machine;

- Daily inspect the machine before use and after dropping or other impacts to identify any significant defects;

⚠ WARNING!

Do not use the machine when the operator is tired, ill or under the influence of alcohol or other drugs;

⚠ WARNING!

Keep bystanders at least 15 m away from the machine during its operation;

⚠ WARNING!

- The emission of exhaust gases come from machine;
- Keep firm footing and balance during operation, use the harness provided.

THROTTLE LOCKOUT

The throttle lockout is designed to prevent accidental operation of the throttle control. When you press the lock (A) (i.e. When you grasp the handle) it releases the throttle control (B). When you release the handle the throttle control and the throttle lockout both move back to their original positions. This movement is controlled by two independent return springs.

This arrangement means that the throttle control is automatically locked at the idle setting.

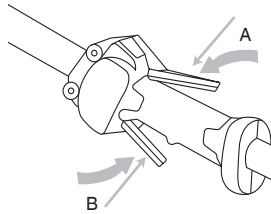

Make sure the throttle control is locked at the idle setting when the throttle lockout is released.

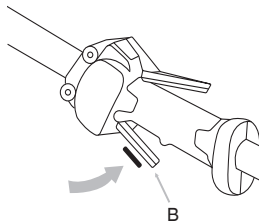

Press the throttle lockout and make sure it returns to its original position when you release it.

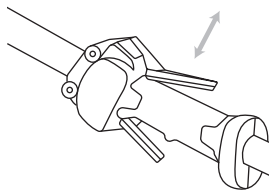

Check that the throttle control and throttle lockout move freely and that the return springs work properly.

See instructions under the heading Start. Start the machine and apply full throttle. Release the throttle and check that the cutting attachment stops and remains at a standstill. If the cutting attachment rotates with the throttle in the idle position, then the carburetor idle setting must be checked.

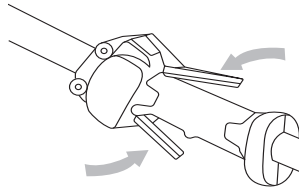

ENGINE SWITCH

Press down the “O” side of the engine switch to stop the engine. Start the engine and make sure the engine stops when you move the engine switch to the stop setting.

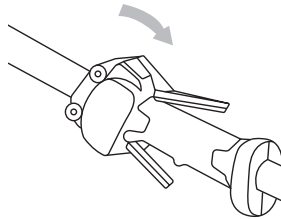

CUTTING ATTACHMENT GUARD

This guard is intended to prevent loose objects from being thrown towards the operator. The guard also protects the operator from accidental contact with the cutting attachment.

Check that the guard is undamaged and not cracked. Replace the guard if it has been exposed to impact or is cracked.

Always use the recommended guard for the cutting attachment you are using. See chapter on Technical data.

⚠ WARNING!

Never use a cutting attachment without an approved guard. See the chapter on Technical data. If an incorrect or faulty guard is fitted this can cause serious personal injury.

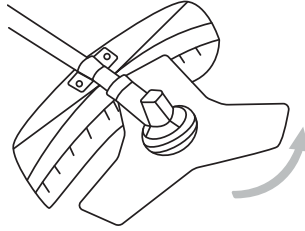

VIBRATION DAMPING SYSTEM

Your machine is equipped with a vibration damping system that is designed to minimize vibration and make operation easier.

Using incorrectly wound cord or a blunt or incorrect cutting attachment (wrong type or incorrectly filed, see instructions under the heading Filing the blade) increases the level of vibration.

The machine's vibration damping system reduces the transfer of vibration between the engine unit/cutting equipment and the machine's handle unit.

Regularly check the vibration damping units for cracks or deformation.

Check that the vibration damping element is undamaged and securely attached.

⚠ WARNING!

Overexposure to vibration can lead to circulatory damage or nerve damage in people who have impaired circulation. Contact your doctor if you experience symptoms of overexposure to vibration. Such symptoms include numbness, loss of feeling, tingling, pricking, pain, loss of strength, changes in skin color or condition. These symptoms normally appear in the fingers, hands or wrists. The risk increases at low temperatures.

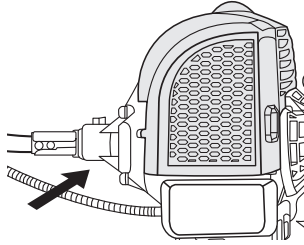

QUICK RELEASE

There are two easily accessible, quick releases fitted at the front and side as a safety precaution in case the engine catches fire, or in any other situation that requires you to free yourself from the machine and harness. See instructions under the heading Adjusting the harness and brush cutter. Check that the harness straps are correctly positioned. Once the harness and machine have been adjusted, check that the harness quick release works correctly.

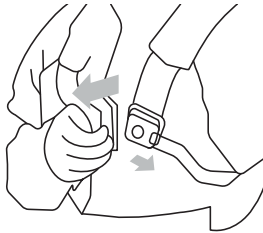

MUFFLER

The inside of the muffler contains chemicals that may be carcinogenic.

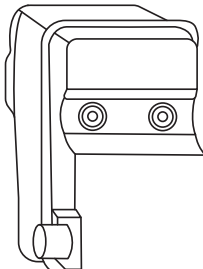

Avoid contact with these elements in the event of a damaged muffler.

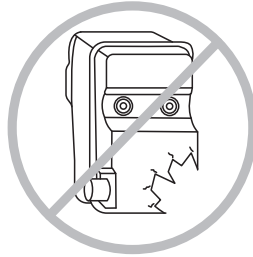

Bear in mind that: The exhaust fumes from the engine are hot and may contain sparks which can start a fire.

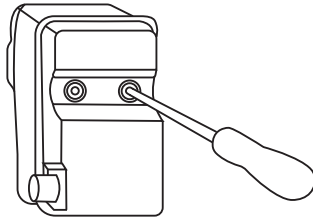

⚠ WARNING!

Never start the machine indoors or near combustible material

LOCKING NUT

A locking nut is used to secure some types of cutting attachment.

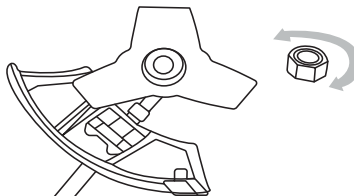

When fitting, tighten the nut in the opposite direction to the direction of rotation of the cutting attachment. To remove it, undo the nut in the same direction as the cutting attachment rotates.

⚠ CAUTION!

The nut has a left-hand thread. Tighten the nut using the socket spanner. The nylon lining inside the locking nut must not be so worn that you can turn it by hand. The lining should offer a resistance of at least 1.5 NM. The nut should be replaced after it has been put on approx. 10 times.

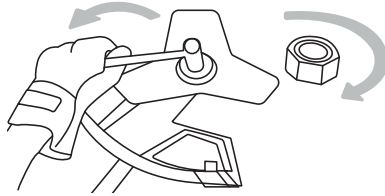
**CUTTING EQUIPMENT**

This section describes how to choose and maintain your cutting equipment in order to:

- Reduce the risk of blade thrust.
- Obtain maximum cutting performance.
- Extend the life of cutting equipment.

⚠ IMPORTANT:

- Only use cutting attachments with the guards we recommend! See the chapter on Technical data.
- Refer to the instructions for the cutting attachment to check the correct way to load the cord and the correct cord diameter.
- Keep the teeth of the blade correctly sharpened! Follow our recommendations. Also refer to the instructions on the blade packaging.

⚠ WARNING!

Always stop the engine before doing any work on the cutting attachment. This continues to rotate even after the throttle has been released. Ensure that the cutting attachment has stopped completely and disconnect the HT lead from the spark plug before you start to work on it.

⚠ WARNING!

Using an incorrect cutting attachment or an incorrectly sharpened blade increases the risk of blade thrust.

- Grass blades and grass cutters are intended to cut weeds, brush, small trees and similar vegetation.

■ TRIMMER HEAD

⚠ WARNING!

Always ensure the trimmer cord is wound tightly and evenly around the drum, otherwise the machine will generate harmful vibration.

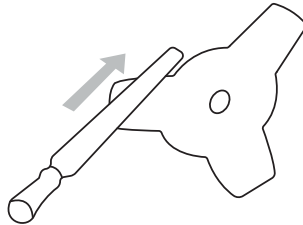

Only use the recommended trimmer heads and trimmer cords. These have been tested by the manufacturer to suit a particular engine size. This is especially important when a fully automatic trimmer head is used. Only use the recommended cutting attachment. See the chapter on Technical data.

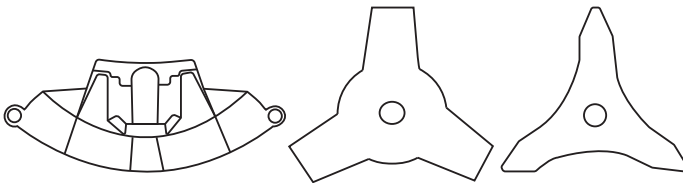

Smaller machines generally require small trimmer heads and vice versa. This is because when clearing using a cord the engine must throw out the cord radially from the trimmer head and overcome the resistance of the grass being cleared.

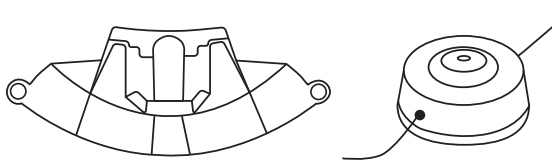

The length of the cord is also important. A longer cord requires greater engine power than a shorter cord of the same diameter. Make sure that the cutter on the trimmer guard is intact. This is used to cut the cord to the correct length. To increase the life of the cord it can be soaked in water for a couple of days. This will make the line tougher so that it lasts longer.

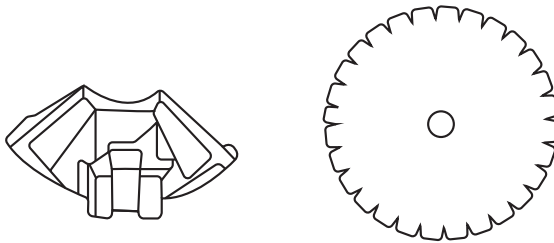

FITTING THE MAIN BODY

Connect the engine (A) to the output flange (B) with four screws (C).

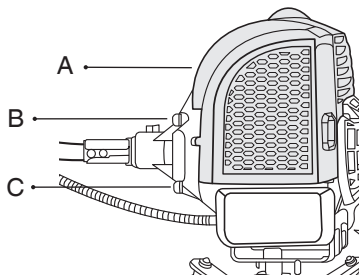

ASSEMBLING THE FRONT HANDLE

Fit the front handle assembly (B) and the clamp (C) on the tube (A) using two combinations of plate washer (D)N spring washer (E) and screw (F).

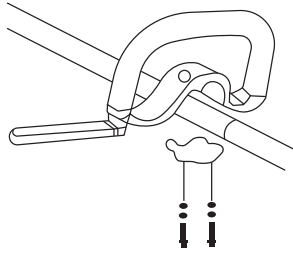

ASSEMBLING THE FLEXIBLE SHAFT

Pull out the locking pin (K). Align the flexible shaft (H) and the clutch (J), and insert the flexible shaft tube (G) into the clutch cover until the position hole (G1) align with the locking pin (K). Loosen the locking pin.

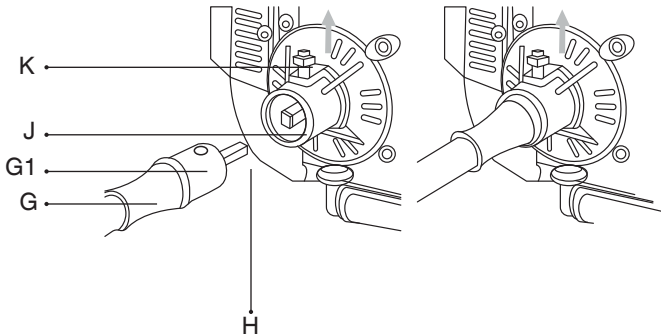

CONNECT THE THROTTLE CABLE

Connect the operation cable (L) and the throttle cable (M). Then close the throttle cable connector.

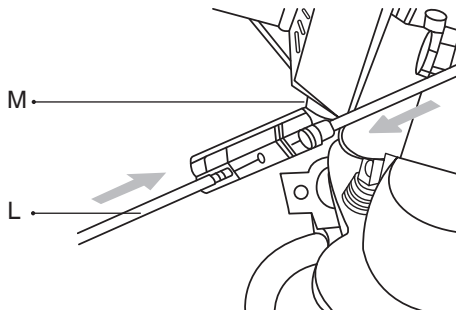

■ FITTING BLADES AND TRIMMER HEADS

⚠ WARNING!

When fitting the cutting attachment, it is extremely important that the raised section on the top clamping plate/support flange engages correctly in the center hole of the cutting attachment. If the cutting attachment is fitted incorrectly it can result in serious and/or fatal personal injury.

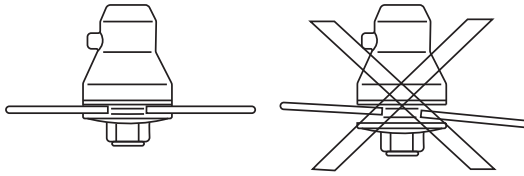

- Never use a cutting attachment without an approved guard. See the chapter on Technical data. If an incorrect or faulty guard is fitted this can cause serious personal injury.

⚠ IMPORTANT:

If a saw blade or grass blade is to be used the machine must be equipped with the correct handlebar, blade guard and harness.

FITTING THE GUARD EXTENSION

The guard extension shall always be fitted when using the trimmer head and combination guard. The guard extension shall always be removed when using the grass blade and combination guard.

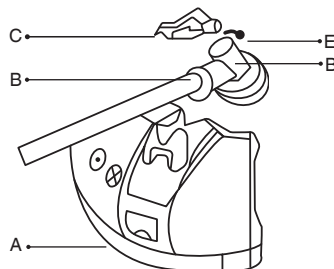

Use a screw (E) fix the fitting (C) on the gear box (B). Hook the guard (A) onto the fitting, and then secure with a bolt (D).

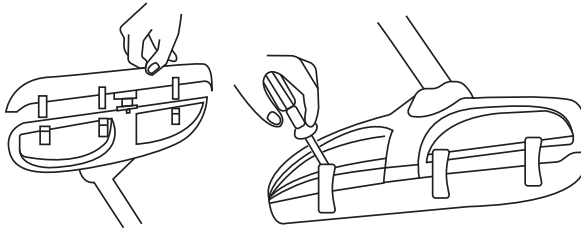

The guard extension is removed easily using a screwdriver, see illustration.

FITTING A BLADE GUARD, GRASS BLADE AND GRASS CUTTER

Use a screw (E) fix the fitting (C) on the gear box (B). Hook the guard (A) onto the fitting (C), and then secure with a bolt (D).

⚠ CAUTION!

Ensure that the guard extension is removed.

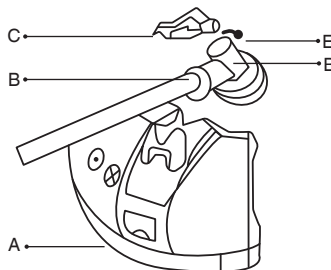

- Fit the top clamping plate (B) on the output shaft.
- Turn the blade shaft until one of the holes in the top clamping plate aligns with the corresponding hole in the top protecting cap.
- Insert the locking pin (A) in the hole to lock the shaft.

- Place the saw blade (C), bottom clamping plate (D) and bottom protecting cap (E) on the output shaft.
- Fit the nut (F). The nut must be tightened to a torque of 35-50 Nm. Use the socket spanner in the tool kit. Hold the shaft of the spanner as close to the blade guard as possible. To tighten the nut, turn the spanner in the opposite direction to the direction of rotation.

⚠ CAUTION!

left-hand thread. Pull out the locking pin after all installation process has been finished.

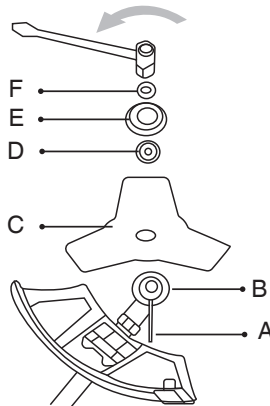

FITTING THE TRIMMER GUARD AND TRIMMER HEAD

- Fit the correct trimmer guard for use with the trimmer head.

⚠ CAUTION!

Ensure that the guard extension is fitted.

- Hook the trimmer guard/combination guard onto the fitting on the shaft and secure with three bolts.
- Fit the top clamping plate (B) on the output shaft.
- Turn the blade shaft until one of the holes in the top clamping plate aligns with the corresponding hole in the top protecting cap (C).

- Insert the locking pin (A) in the hole to lock the shaft.
- Screw on the trimmer head (D) in the opposite direction to the direction of rotation.
- To dismantle, follow the instructions in the reverse order.

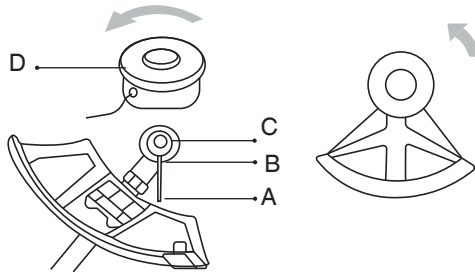

ADJUSTING THE HARNESS AND BRUSH CUTTER

⚠ WARNING!

When using a brush cutter, it must always be hooked securely to the harness. Otherwise you will be unable to control the brush cutter safely and this can result in injury to yourself or others. Never use a harness with a defective quick release.

QUICK RELEASE

At the front is an easily accessible, quick release. Use this if the engine catches fire or in any other emergency situation that requires you to free yourself from the machine and harness.

■ SPREADING THE LOAD ON YOUR SHOULDERS SPREADING THE LOAD ON YOUR SHOULDERS

A well-adjusted harness and machine makes work much easier. Adjust the harness for the best working position. Tension the side straps so that the weight is evenly distributed across both shoulders.

■ CORRECT BALANCE

Let the cutting attachment rest lightly on the ground. Adjust the position of the suspension ring to balance the brush cutter correctly.

■ FUEL SAFETY

Never start the machine:

- If you have spilt fuel on it. Wipe off the spillage and allow remaining fuel to evaporate.
- If you have spilt fuel on yourself or your clothes, change your clothes. Wash any part of your body that has come in contact with fuel. Use soap and water.
- If the machine is leaking fuel. Check regularly for leaks from the fuel cap and fuel lines.

■ TRANSPORT AND STORAGE

- Store and transport the machine and fuel so that there is no risk of any leakage or fumes coming into contact with sparks or naked flames, for example, from electrical machinery, electric motors, electrical relays/switches or boilers.
- When storing and transporting fuel always use approved containers intended for this purpose.
- When storing the machine for long periods the fuel tank must be emptied. Contact your local petrol station to find out where to dispose of excess fuel.
- Ensure the machine is cleaned and that a complete service is carried out before long-term storage.
- The transport guard must always be fitted to the cutting attachment when the machine is being transported or in storage.
- Secure the machine during transport.
- In order to prevent unintentional starting of the engine, the spark plug cap must always be removed during long-term storage, if the machine is not under close supervision and when performing all service measures.

■ FUEL

WARNING!

Take care when handling fuel. Bear in mind the risk of fire, explosion and inhaling fumes.

CAUTION!

The machine is equipped with a two-stroke engine and must always be run using a mixture of petrol and two-stroke oil. It is important to accurately measure the amount of oil to be mixed to ensure that the correct mixture is obtained. When mixing small amounts of fuel, even small inaccuracies can drastically affect the ratio of the mixture.

WARNING!

Fuel and fuel fumes are highly inflammable and can cause serious injury when inhaled or allowed to come in contact with the skin. For this reason, observe caution when handling fuel and make sure there is adequate ventilation.

■ PETROL

CAUTION!

- Always use a quality petrol/oil mixture at least 90 octane (RON). If your machine is equipped with a catalytic converter (see chapter on Technical data) always use a good quality unleaded petrol/oil mixture. Leaded petrol will destroy the catalytic converter. Use low-emission petrol, also known as alkylate petrol, if it is available.
- The lowest octane recommended is 90 (RON). If you run the engine on a lower octane grade than 90 so-called knocking can occur. This gives rise to a high engine temperature, which can result in serious engine damage.
- When working at continuous high revs a higher octane rating is recommended.

■ TWO-STROKE OIL

- For best results and performance use two-stroke engine oil, which is specially formulated for our air-cooled two-stroke engines.
- Never use two-stroke oil intended for water-cooled engines, sometimes referred to as outboard oil (rated TCW)
- Never use oil intended for four-stroke engines.
- A poor oil quality and/or too high oil/fuel ratio may jeopardize function and decrease the life time of catalytic converters.

MIXING RATIO: 1:35 (PETROL, LITER: TWO-STROKE OIL, MILLILITER)

■ MIXING

Always mix the petrol and oil in a clean container intended for fuel. Always start by filling half the amount of the petrol to be used. Then add the entire amount of oil. Mix (shake) the fuel mixture. Add the remaining amount of petrol.

Mix (shake) the fuel mixture thoroughly before filling the machine's fuel tank. Do not mix more than one month's supply of fuel at a time.

If the machine is not used for some time the fuel tank should be emptied and cleaned.

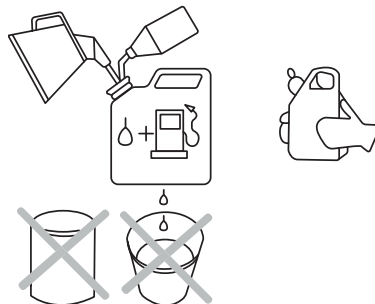

■ FUELING

- Taking the following precautions, will lessen the risk of fire:
- Do not smoke or place hot objects near fuel.

- Always shut off the engine before refueling.
- Always stop the engine and let it cool for a few minutes before refueling.
- When refueling, open the fuel cap slowly so that any excess pressure is released gently.
- Tighten the fuel cap carefully after refueling.
- Always move the machine away from the refueling area before starting.

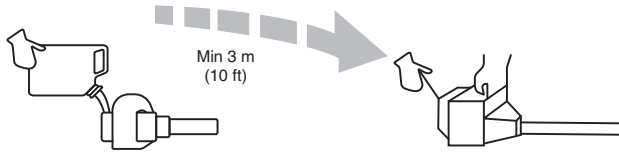

■ CHECK BEFORE STARTING

Never use the machine without a guard nor with a defective guard. All covers must be correctly fitted and undamaged before you start the machine.

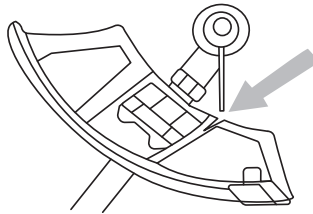

Check the blade to ensure that no cracks have formed at the bottom of the teeth or by the center hole.

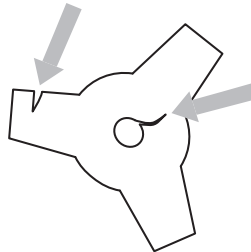

The most common reason why cracks are formed is that sharp corners have been formed at the bottom of the teeth while sharpening or that the blade has been used with dull teeth. Discard a blade if cracks are found.

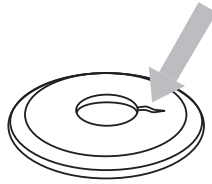

Check that the support flange is not cracked due to fatigue or due to being tightened too much. Discard the support flange if it is cracked.

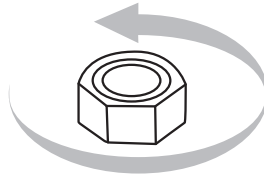

Ensure the locking nut has not lost its captive force. The nut lock should have a locking force of at least 1.5 NM. The tightening torque of the locking nut should be 35-50 NM.

Check that the blade guard is not damaged or cracked. Replace the blade guard if it is exposed to impact or is cracked.

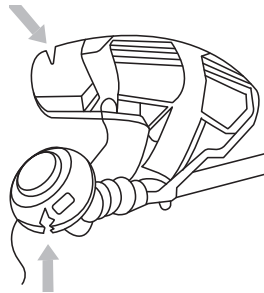

Check that the trimmer head and trimmer guard are not damaged or cracked. Replace the trimmer head or trimmer guard if they have been exposed to impact or are cracked.

PRIMER BULB

Press the air purge repeatedly until fuel begins to fill the bulb. The bulb need not be completely filled.

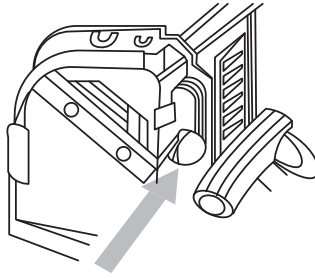

CHOKE

Set the choke knob(A) in the choke position.

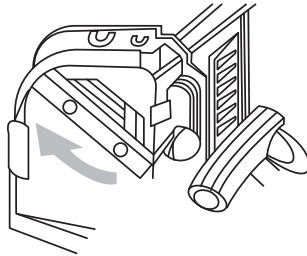

WARNING!

The complete clutch cover and shaft must be fitted before the machine is started, otherwise the clutch can come loose and cause personal injury. Always move the machine away from the refueling area before starting. Place the machine on a flat surface. Ensure the cutting attachment cannot come into contact with any object.

Make sure no unauthorized persons are in the working area, otherwise there is a risk of serious personal injury. The safety distance is 15 meters.

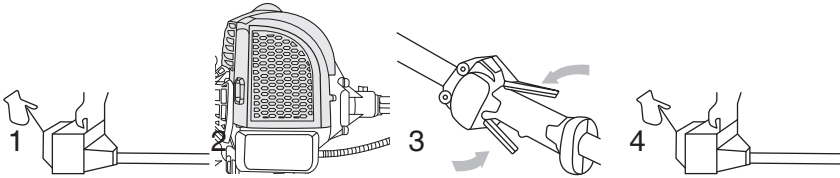

STARTING AND STOPPING

Ignition: Press down the “I” side of the engine switch.

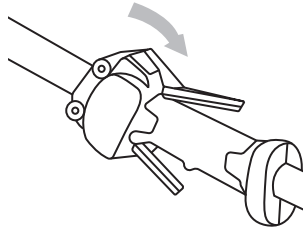

⚠ WARNING!

The choke will automatically return to the run position by operating the throttle trigger. If you manually turn the choke knob from choke position to run position, the cutting attachment will start to rotate immediately when the engine is started. Hold the body of the machine on the ground using your left hand.

⚠ CAUTION!

Not with your foot! Grip the starter handle, slowly pull out the cord with your right hand until you feel some resistance (the starter pawls grip), now quickly and powerfully pull the cord. Never twist the starter cord around your hand. Repeat pulling the cord until engine firing occur, then operate the throttle to allow the choke return to the run position. Repeat pulling the cord until engine start. When the engine starts, allow the engine to warm up with the throttle pulled slightly.

⚠ CAUTION!

Do not pull the starter cord all the way out and do not let go of the starter handle when the cord is fully extended. This can damage the machine.

⚠ CAUTION!

Do not put any part of your body in marked area. Contact can result in burns to the skin, or electrical shock if the spark plug cap has been damaged. Always use gloves. Do not use a machine with damaged spark plug cap.

Stopping Stop the engine by switching off the ignition.

WORKING TECHNIQUES

General working instructions

⚠ WARNING!

- This section describes the basic safety precautions for working with brush cutters and trimmers.
- If you encounter a situation where you are uncertain how to proceed you should ask an expert. Contact your dealer or your service workshop.
- Avoid all usage which you consider to be beyond your capability.
- You must understand the difference between forestry clearing, grass clearing and grass trimming before use.

BASIC SAFETY RULES

Look around you:

To ensure that people, animals or other things cannot affect your control of the machine.

To ensure that people, animals, etc., do not come into contact with the cutting attachment or loose objects that are thrown out by the cutting attachment.

⚠ CAUTION!

Do not use the machine unless you are able to call for help in the event of an accident. Inspect the working area. Remove all loose objects, such as stones, broken glass, nails, steel wire, string, etc. that could be thrown out or become wrapped around the cutting attachment. Do not use the machine in bad weather, such as dense fog, heavy rain, strong wind, intense cold, etc. Working in bad weather is tiring and often brings added risks, such as icy ground, unpredictable felling direction, etc. Make sure you can move and stand safely. Check the area around you for possible obstacles (roots, rocks, branches, ditches, etc.) in case you have to move suddenly. Take great care when working on sloping ground.

WORKING TECHNIQUES

Keep the cutting attachment below waist level.

Switch off the engine before moving to another area. Fit the transport guard before carrying or transporting the equipment any distance.

Never put the machine down with the engine running unless you have it in clear sight.

⚠ WARNING!

Neither the operator of the machine nor anyone else may attempt to remove the cut material while the engine is running or the cutting equipment is rotating, as this can result in serious injury.

Stop the engine and cutting equipment before you remove material that has wound around the blade shaft as otherwise there is a risk of injury.

The bevel gear can get hot during use and may remain so for a while afterwards. You could get burnt if you touch it.

WARNING! Watch out for thrown objects. Always wear approved eye protection. Never lean over the cutting attachment guard. Stones, rubbish, etc. can be thrown up into the eyes causing blindness or serious injury.

Keep unauthorized persons at a distance. Children, animals, onlookers and helpers should be kept outside the safety zone of 15 m. Stop the

machine immediately if anyone approaches. Never swing the machine around without first checking behind you to make sure no-one is within the safety zone.

Basic working techniques

Always slow the engine to idle speed after each working operation. Long periods at full throttle without any load on the engine can lead to serious engine damage.

WARNING!

Sometimes branches or grass get caught between the guard and cutting attachment. Always stop the engine before cleaning.

WARNING! Machines fitted with grass blades can be thrown violently to the side when the blade comes into contact with a fixed object. This is called blade thrust. A blade thrust can be violent enough to cause the machine and/or operator to be propelled in any direction, and possibly lose control of the machine. Blade thrust can occur without warning if the machine snags, stalls or binds. Blade thrust is more likely to occur in areas where it is difficult to see the material being cut.

Avoid cutting with the area of the blade between the 12 o'clock and 3 o'clock positions. Because of the speed of rotation of the blade, blade thrust can occur if you attempt to cut thick stems with this area of the blade.

- Grass clearing using a grass blade
- Grass blades and grass cutters must not be used on woody stems.
- A grass blade is used for all types of tall or coarse grass.

The grass is cut down with a sideways, swinging movement, where the movement from right-to-left is the clearing stroke and the movement from left-to-right is the return stroke. Let the left-hand side of the blade (between 8 and 12 o'clock) do the cutting.

- If the blade is angled to the left when clearing grass, the grass will collect in a line, which makes it easier to collect, e.g. by raking.
- Try to work rhythmically. Stand firmly with your feet apart. Move forward after the return stroke and stand firmly again.

- Let the support cup rest lightly against the ground. It is used to protect the blade from hitting the ground

■REDUCE THE RISK OF MATERIAL WRAPPING AROUND THE BLADE BY FOLLOWING THESE INSTRUCTIONS:

- 1) Always work at full throttle.
- 2) Avoid the previously cut material during the return stroke.
- 3) Stop the engine, unclip the harness and place the machine on the ground before you start to collect the cut material.

GRASS TRIMMING WITH A TRIMMER HEAD

■TRIMMING

- Hold the trimmer head just above the ground at an angle. It is the end of the cord that does the work. Let the cord work at its own pace. Never press the cord into the area to be cut.

- The cord can easily remove grass and weeds up against walls, fences, trees and borders, however it can also damage sensitive bark on trees and bushes, and damage fence posts.

- Reduce the risk of damaging plants by shortening the cord to 10-12 cm and reducing the engine speed.

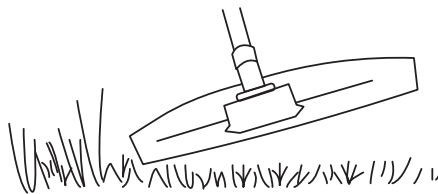

■CLEARING

- The clearing technique removes all unwanted vegetation. Keep the trimmer head just above the ground and tilt it. Let the end of the cord strike the ground around trees, posts, statues and the like.

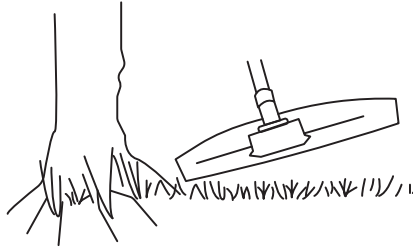

⚠ CAUTION!

- This technique increases the wear on the cord.
- The cord wears quicker and must be fed forward more often when working against stones, brick, concrete, metal fences, etc., than when coming into contact with trees and wooden fences.
- When trimming and clearing you should use less than full throttle so that the cord lasts longer and to reduce the wear on the trimmer head.

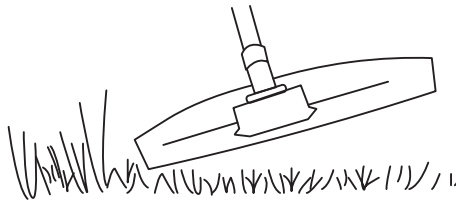

■ CUTTING

The trimmer is ideal for cutting grass that is difficult to reach using a normal lawn mower. Keep the cord parallel to the ground when cutting. Avoid pressing the trimmer head against the ground as this can ruin the lawn and damage the tool. When cutting and sweeping you should use full throttle to obtain the best results.

CARBURETOR

■ ADJUSTING THE IDLE SPEED (T)

Check that the air filter is clean. When the idle speed is correct, the cutting attachment should not rotate. If adjustment is required, close

(turn clockwise) the idle adjustment screw T, with the engine running, until the cutting attachment starts to rotate. Open (turn anticlockwise) the screw until the cutting attachment stops. The idle speed is correctly set when the engine runs smoothly in all positions, and there is a clear margin to the speed at which the cutting attachment starts to rotate.

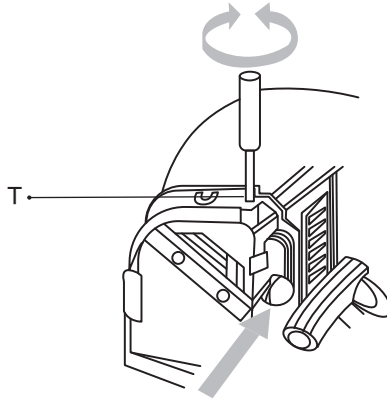

⚠ WARNING!

If the idle speed cannot be adjusted so that the cutting attachment stops, contact your dealer/service workshop. Do not use the machine until it has been correctly adjusted or repaired.

If you need to adjust the “L” and/or “H” mixture screw contact with your dealer/service center for some help.

AIR FILTER

The air filter must be regularly cleaned to remove dust and dirt in order to avoid:

- Carburetor malfunctions
- Starting problems
- Loss of engine power
- Unnecessary wear to engine parts.
- Excessive fuel consumption.

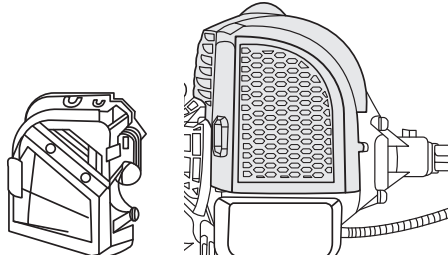

■ CLEAN THE FILTER

every 25 hours, or more regularly if conditions are exceptionally dusty.
Cleaning the air filter

Remove the air filter cover and take out the filter. Wash it clean in warm, soapy water. Ensure that the filter is dry before refitting it.

An air filter that has been in use for a long time cannot be cleaned completely. The filter must therefore be replaced with a new one at regular intervals. A damaged air filter must always be replaced.

FUEL FILTER

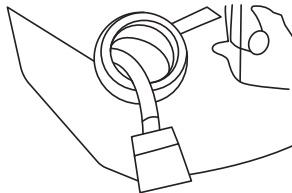

When the engine runs short of fuel supply, check the fuel cap and the fuel filter (1) for blockage.

BEVEL GEAR

The bevel gear is filled with the right quantity of grease at the factory. However, before using the machine you should check that the bevel gear is filled three-quarters full with grease. Use HUSQVARNA special grease.

The grease in the bevel gear does not normally need to be changed

except if repairs are carried out.

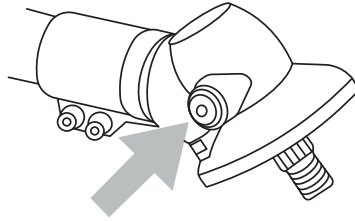

SPARK PLUG

The spark plug condition is influenced by:

- Incorrect carburetor adjustment.
- An incorrect fuel mixture (too much or incorrect type of oil).
- A dirty air filter.

These factors cause deposits on the spark plug electrodes, which may result in operating problems and starting difficulties. If the machine is low on power, difficult to start or runs poorly at idle speed: always check the spark plug first before taking any further action. If the spark plug is dirty, clean it and check that the electrode gap is 0,6-0,7 mm. The spark plug should be replaced after about a month in operation or earlier if necessary.

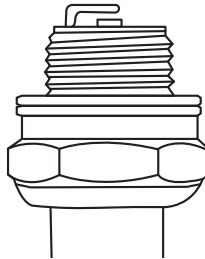

Recommended Spark plug type: CHAMPION RCJ7Y

CAUTION!

Always use the recommended spark plug type! Use of the wrong spark plug can damage the piston/ cylinder. Check that the spark plug is fitted with a suppressor.

MAINTENANCE SCHEDULE

The following is a list of the maintenance that must be performed on the machine. Most of the items are described in the Maintenance section. The user must only carry out the maintenance and service work described in this Operator's Manual. More extensive work must be carried out by an authorized service workshop.

Maintenance	Daily maintenance	Weekly maintenance	Monthly maintenance
Clean the outside of the machine.	X		
Check that the harness is not damaged.	X		
Make sure the throttle trigger lock and the throttle function correctly from a safety point of view.	X		
Check that the handle and handlebar are undamaged and secured correctly.	X		
Check that the stop switch works correctly.	X		
Check that the cutting attachment does not rotate at idle.	X		
Clean the air filter. Replace if necessary.	X		
Check that the guard is undamaged and not cracked. Replace the guard if it has been exposed to impact or is cracked.	X		
Check that the blade is correctly centered, is sharp, and is not cracked. An off-center blade will cause vibration that could result in damage to the machine.	X		
Check that the trimmer head is undamaged and not cracked. Replace the trimmer head if necessary.	X		

Check that the locking nut of the cutting equipment is tighten correctly.	X		
Check that the transport guard for the blade is intact and that it can be secured correctly.	X		
Check that nuts and screws are tight.	X		
Check that there are no fuel leaks from the engine, tank or fuel lines.	X		
Check the starter and starter cord.		X	
Check that the vibration damping elements are not damaged.		X	
Clean the outside of the spark plug. Remove it and check the electrode gap. Adjust the gap to 0,6-0,7 mm or replace the spark plug. Check that the spark plug is fitted with a suppressor.		X	
Clean the outside of the carburetor and the space around it.		X	
Check that the bevel gear is filled three-quarters full with lubricant. Fill if necessary using special grease.		X	
Check the fuel filter from contamination and the fuel hose from cracks or other defects. Replace if necessary.			X
Check all cables and connections.			X
Check the clutch, clutch springs and the clutch drum for wear. Replace if necessary by an authorized service workshop.			X
Replace the spark plug. Check that the spark plug is fitted with a suppressor.			X

Ronix[®]
Premium Quality

www-ronixtools.com